

Excellent Integrated System Limited

Stocking Distributor

Click to view price, real time Inventory, Delivery & Lifecycle Information:

[E-Switch](#)
[700SP7B20VS2RE](#)

For any questions, you can email us directly:

sales@integrated-circuit.com

SHEET 1 OF 1

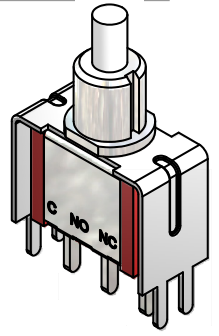
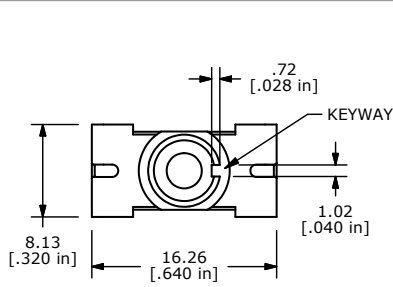
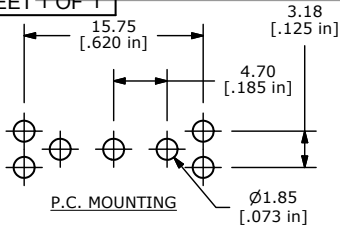

SWITCH FUNCTION	
POS. 1	POS. 2
ON	(ON)
1-3	1-2

(ON)=MOMENTARY

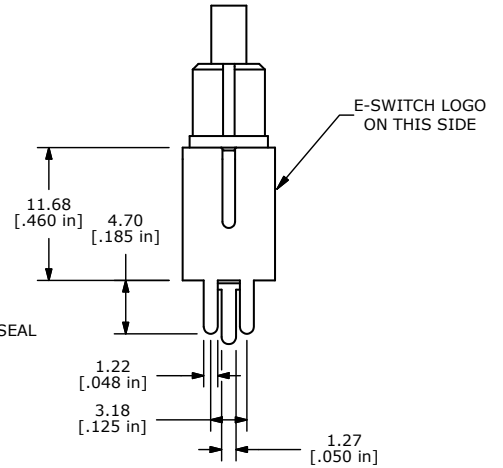
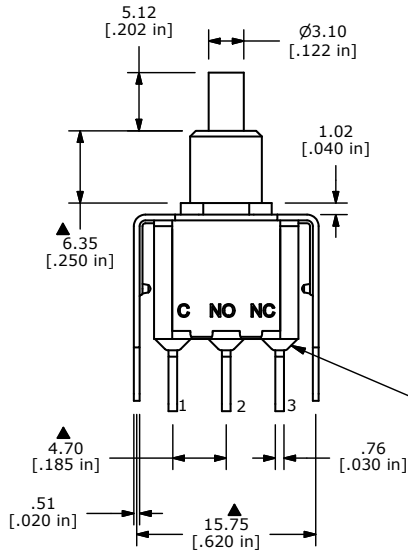
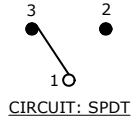

- NOTE:
1. ALL DIMENSIONS IN MM [INCH]
 2. GENERAL TOLERANCE: X.X=±0.4
X.XX=±0.25
 3. TERMINAL NUMBERS FOR REF ONLY
 4. CONTACT MATERIAL: GOLD
 5. RATING: 0.4VA MAX. @ 20 VAC OR VDC MAX.
 6. ELECTRIC LIFE: 50,000 MAKE-AND-BREAK CYCLES AT FULL LOAD
 7. INSULATION RESISTANCE: 1,000 MEGA-OHM MIN.
 8. ACUATION FORCE: 300 ± 100gf
 9. TRAVEL: 1.0 ± 0.2mm
 10. CONTACT RESISTANCE: 20 mOHM MAX. TYPICAL @ 2-4 VDC
 11. DIELECTRIC STRENGTH: 1,000 V RMS @ SEA LEVEL.
 12. OPERATING TEMP.: -30°C to 85°C
 13. ▲ DENOTES CRITICAL PARAMETER.
 14. 2002/95/EC (ROHS) COMPLIANT.



C	20004	DRAWING UPDATE / CLEAN-UP	6/14/11	BGL
REV	PCR NO	DESCRIPTION	DATE	BY

THE INFORMATION CONTAINED IN THIS DOCUMENT IS PROPRIETARY TO E-SWITCH AND IS NOT TO BE COPIED OR TRANSFERRED

TITLE 700SP7B20VS2RE				
SCALE 2:1	DATE 6/14/2011	DR BGL	DWG T711020	REV C