

## Excellent Integrated System Limited

Stocking Distributor

Click to view price, real time Inventory, Delivery & Lifecycle Information:

[E-Switch](#)  
[KC13B7.001NLS](#)

For any questions, you can email us directly:

[sales@integrated-circuit.com](mailto:sales@integrated-circuit.com)

SHEET 1 OF 1

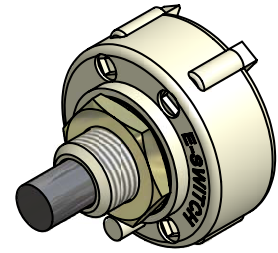
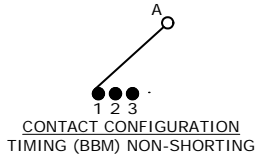

ISOMETRIC

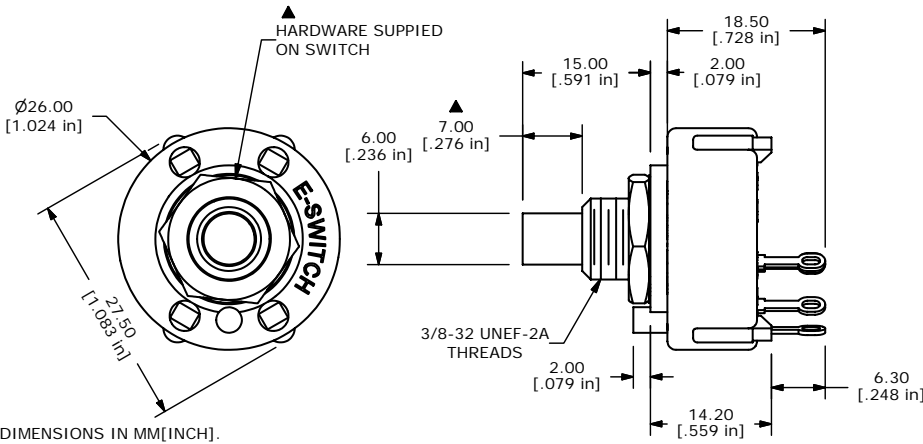
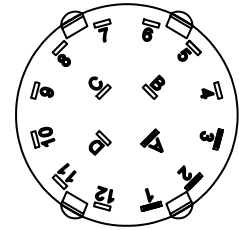

- NOTE:
1. ALL DIMENSIONS IN MM[INCH].
  2. GENERAL TOLERANCE: X.X=±0.4  
X.XX=±0.25
  3. TERM. NOS. FOR REFERENCE ONLY.
  4. CONTACT MATERIAL: SILVER ALLOY
  5. CONTACT RATING: 0.3A @ 125VAC
  6. OPERATING FORCE 800±300gm-cm
  7. OPERATING TEMP: -30°C TO 85°C
  - ▲ 8. CIRCUIT SP: 3 POSITION 30° INDEX.
  9. DIELECTRIC STRENGTH: 500VAC FOR 1 MIN.
  - ▲ 10. HARDWARE SUPPLIED ON SWITCH:  
STOP RING, LOCKWASHER, HEXNUT
  11. 2002/95/EC (ROHS) COMPLIANT
  12. ▲ DENOTES CRITICAL PARAMETER.

**E-SWITCH®**

TITLE KC13B7.001NLS

A	15438	RELEASED FOR PRODUCTION	10/24/05	PH
REV	PCR NO	DESCRIPTION	DATE	BY

THE INFORMATION CONTAINED IN THIS DOCUMENT IS PROPRIETARY TO E-SWITCH AND IS NOT TO BE COPIED OR TRANSFERRED

SCALE	1.5:1	DATE	10/24/2005	DR	PH	DWG	G510606	REV	A
-------	-------	------	------------	----	----	-----	---------	-----	---