

Excellent Integrated System Limited

Stocking Distributor

Click to view price, real time Inventory, Delivery & Lifecycle Information:

[E-Switch](#)
[KC54A7.001NLS](#)

For any questions, you can email us directly:
sales@integrated-circuit.com

SHEET 1 OF 1



CONTACT CONFIGURATION
TIMING (BBM) NON-SHORTING

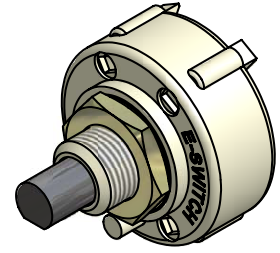

ISOMETRIC

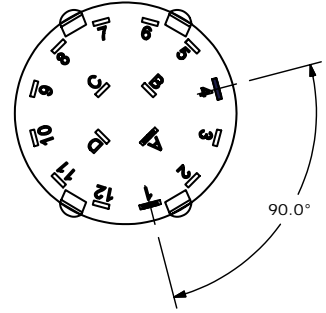
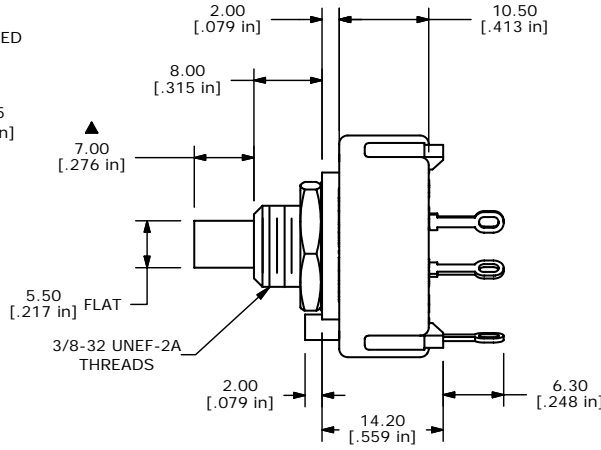
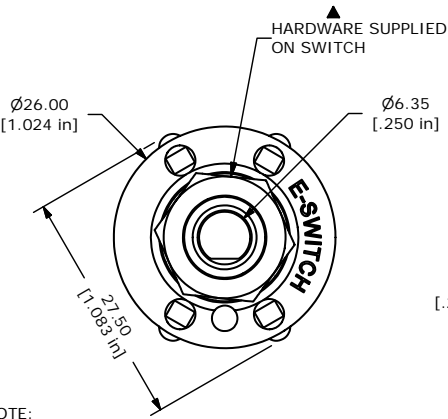

NOTE:

1. ALL DIMENSIONS IN MM[INCH].
2. GENERAL TOLERANCE: X.X±0.4
X.XX±0.25
3. TERM. NOS. FOR REFERENCE ONLY.
- ▲ 4. CONTACT MATERIAL: SILVER
5. CONTACT RATING: 0.3A, 125VAC
6. OPERATING FORCE 800±300GM-CM/STANDARD
7. OPERATING TEMP: -30°C TO 85°C
- ▲ 8. CIRCUIT SP: 2 POSITION 90° INDEX.
9. DIELECTRIC STRENGTH: 500VAC - 1 MIN
- ▲ 10. HARDWARE SUPPLIED ON SWITCH:
LOCKWASHER, HEXNUT, STOP RING
11. ▲ DENOTES CRITICAL PARAMETER.
12. 2002/95/EC (ROHS) COMPLIANT



B	16120	UPDATE TERMINALS AND NOTES	6/8/06	CT
A	16073	RELEASED FOR PRODUCTION	6/1/06	CT
REV	PCR NO	DESCRIPTION	DATE	BY

TITLE KC54A7.001NLS

SCALE	1.5:1	DATE	6/1/2006	DR	CT	DWG	G527564	REV	B
-------	-------	------	----------	----	----	-----	---------	-----	---

THE INFORMATION CONTAINED IN THIS DOCUMENT IS PROPRIETARY TO E-SWITCH AND IS NOT TO BE COPIED OR TRANSFERRED