

Excellent Integrated System Limited

Stocking Distributor

Click to view price, real time Inventory, Delivery & Lifecycle Information:

[E-Switch](#)
[LASOAU110RED](#)

For any questions, you can email us directly:
sales@integrated-circuit.com

SHEET OF

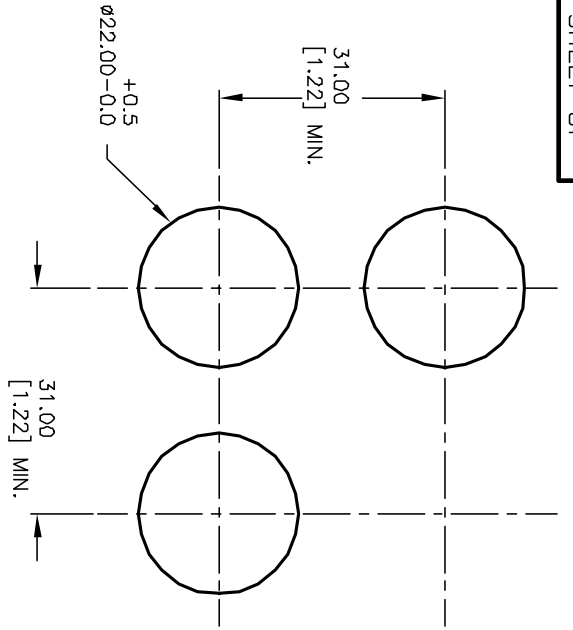

RECOMMENDED PANEL MOUNTING

1 0 1 0 2
 3 0 0 4
 a-D-b (+)

SPST
 CONTACT CONFIGURATION

NOTES:

1. ALL DIMENSIONS IN MM [INCH]
2. GENERAL TOLERANCE: X.X=±0.4
X.XX=±0.25
3. RATINGS: 250VAC @1A, 2A, 4A, 5A

PARTS LIST		
Item	Qty.	Dwg. No. Part No.
1	1	F051701 29mm RING FOR LA SERIES
2	1	F060610 LASOAU110
3	1	F060295 29mm RED LENS

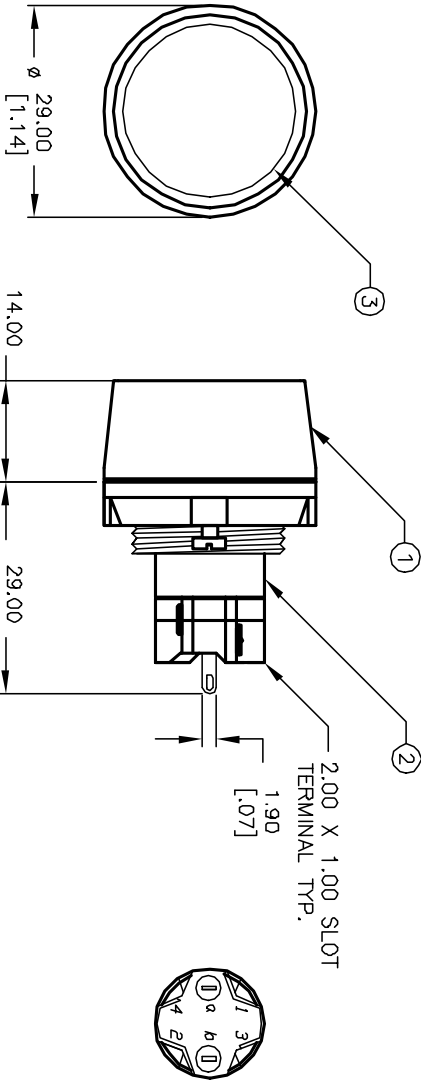

REV.	ECN No.	DESCRIPTION	DATE	CHKD
A	11198	RELEASED FOR PRODUCTION	2/12/02	CJB

TITLE	SCALE	DATE	DR	DWG	REV
LAS DA U1 10 RED (W/D LAMP)	1:1	1/25/01	CJB	XF0348P	A

E-SWITCH®

THE INFORMATION CONTAINED IN THIS DOCUMENT IS PROPRIETARY TO E-SWITCH AND IS NOT TO BE COPIED OR TRANSMITTED