

Excellent Integrated System Limited

Stocking Distributor

Click to view price, real time Inventory, Delivery & Lifecycle Information:

[E-Switch](#)
[LASOAV11KGRNBLU](#)

For any questions, you can email us directly:

sales@integrated-circuit.com

SHEET 1 OF 1

Parts List			
ITEM	QTY	PART NUMBER	DESCRIPTION
1	1	F060606	LASOAV11
2	1	F051702	25MM RING FOR LA SERIES
3	1	F060201	25MM BLUE LENS
4	1	F050422	50-004-22 24VDC LED GRN

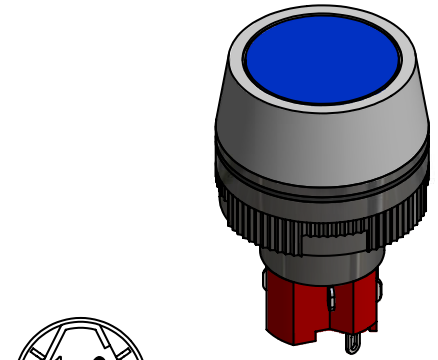
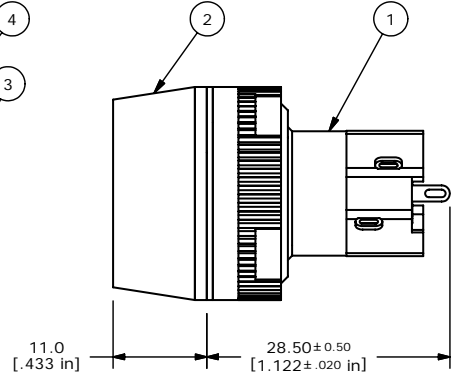
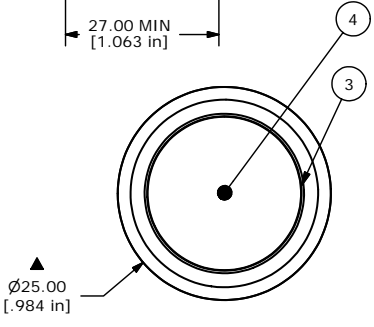
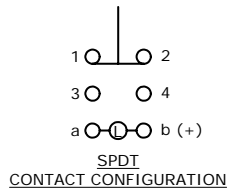
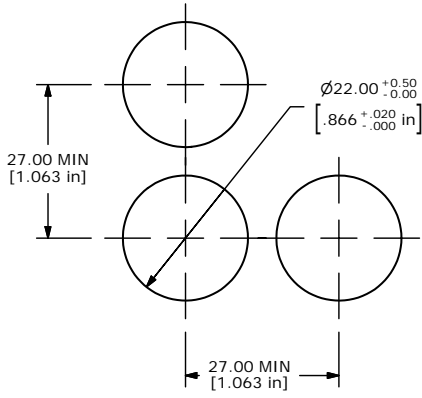

ISOMETRIC



- NOTE:
1. ALL DIMENSIONS IN MM [INCH]
 2. GENERAL TOLERANCE: X.X=±0.4
X.XX=±0.25
 3. TERMINAL NUMBERS FOR REF ONLY
 4. RATING: 5 AMPS @ 250VAC UL, VDE APPROVED
6 AMPS @ 240VDC UL, VDE APPROVED
 5. ELECTRIC LIFE: 25,000 MAKE-AND-BREAK CYCLES AT FULL LOAD.
 6. INSULATION RESISTANCE: 1,000 MEGA-OHM MIN.
 7. OPERATING TEMP.: -25°C to 55°C
 - ▲ 8. LAMP VOLTAGE: 24VDC LED
 9. ▲ DENOTES CRITICAL PARAMETER.



A	15566	RELEASED FOR PRODUCTION	12/1/05	PH
REV	PCR NO	DESCRIPTION	DATE	BY

TITLE LASOAV11KGRNBLU				
SCALE	DATE	DR	DWG	REV
1.5:1	12/1/2005	PH	XF0658P	A

THE INFORMATION CONTAINED IN THIS DOCUMENT IS PROPRIETARY TO E-SWITCH AND IS NOT TO BE COPIED OR TRANSFERRED