

Excellent Integrated System Limited

Stocking Distributor

Click to view price, real time Inventory, Delivery & Lifecycle Information:

[E-Switch](#)
[LL3301NF065QG](#)

For any questions, you can email us directly:
sales@integrated-circuit.com

SHEET 1 OF 1

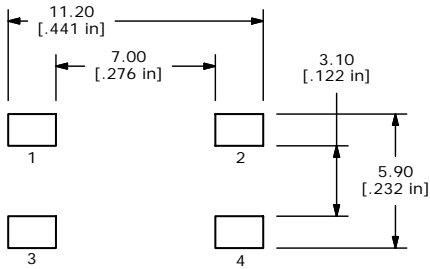

P.C.B. LAYOUT

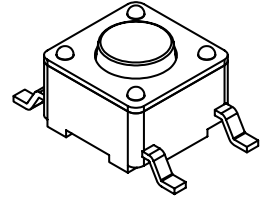
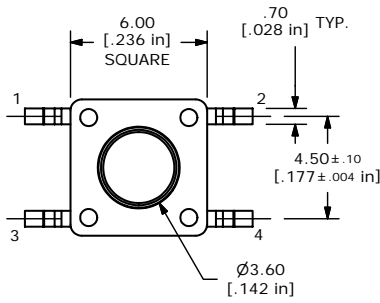

ISOMETRIC

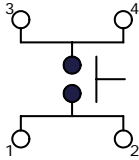

CIRCUIT: SPST

TERMINALS TO BE COPLANER WITHIN 0.10mm

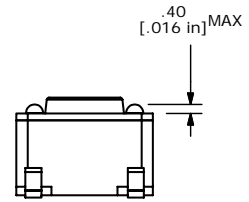
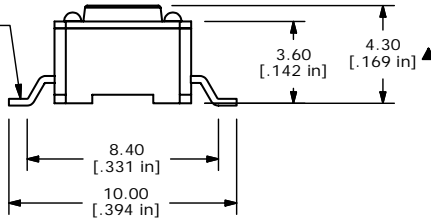

NOTES:

1. ALL DIMENSIONS IN MM [INCH]
2. GENERAL TOLERANCE: x.xx ± 0.4
x.xx ± 0.25
3. TERM. NOS. FOR REF. ONLY
4. RATING: 50mA, @12V DC
5. TRAVEL: 0.25±0.1mm
6. CONTACT RESISTANCE: 50m ohms max initial.MOS & TTC COMPATIBLE
7. ELECTRICAL LIFE: 5,000,000 CYCLES MIN.
8. INSULTION RESISTANCE: 100M ohms min.
9. DIELECTRIC STRENGTH: 250VA
10. OPERATING TEMP.: -30°C to 85°C
11. ▲ DENOTES CRITICAL PARAMETER
- ▲ 12. CONTACTS: SILVER PLATED
- ▲ 13. OPENING FORCE: 65± 20 GRAMS
14. PACKAGING: TAPE AND REEL, 1200 PIECES PER REEL



| | | | | |
|---------------------|---------------|-------|-------------|-------|
| TITLE LL3301NF065QG | | | | |
| SCALE 4:1 | DATE 04/19/06 | DR CT | DWG P090002 | REV A |

| | | | | |
|-----|--------|------------------|---------|----|
| A | 15974 | NEW PART RELEASE | 4/19/06 | CT |
| REV | PCR NO | DESCRIPTION | DATE | BY |

THE INFORMATION CONTAINED IN THIS DOCUMENT IS PROPRIETARY TO E-SWITCH AND IS NOT TO BE COPIED OR TRANSFERRED