

## Excellent Integrated System Limited

Stocking Distributor

Click to view price, real time Inventory, Delivery & Lifecycle Information:

[E-Switch](#)  
[R1973ABLKREDEF2](#)

For any questions, you can email us directly:  
[sales@integrated-circuit.com](mailto:sales@integrated-circuit.com)

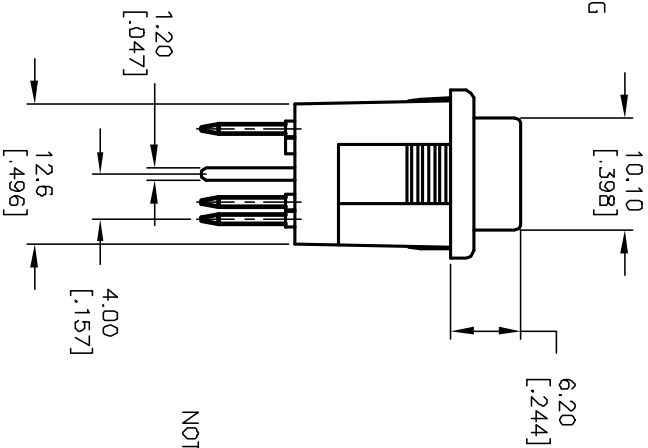
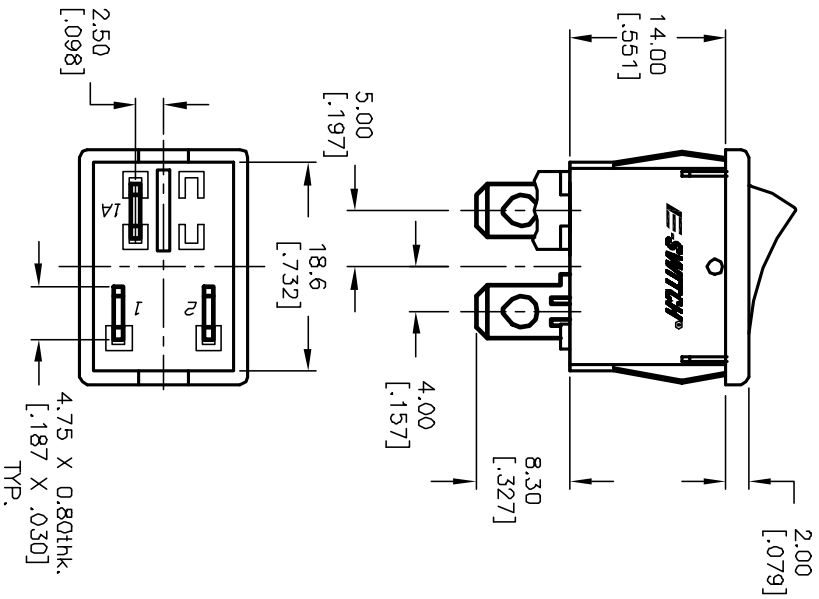
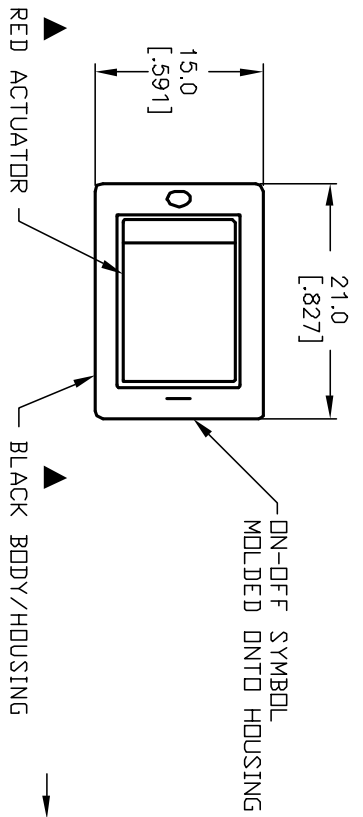

NEON BULB

PARAMETERS	SYMBOL	MAX.	UNITS
LAMP VOLTAGE (AC)	V	250	V
STARTUP VOLTAGE	V <sub>s</sub>	95	V
CURRENT	I	0.8	mA
SERIES RESISTANCE (<math>250V</math>)	R	270	OHMS

PANEL THICKNESS	X dimension
0.75-1.25 [0.30-0.49]	19.2-01 [0.756]
1.25-2.0 [0.49-0.79]	19.4-01 [0.764]
2.0-3.0 [0.79-1.18]	19.8-01 [0.780]

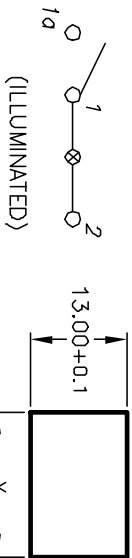

NOTES:

1. ALL DIMENSIONS IN MM [INCH]
2. GENERAL TOLERANCE: X:X=±0.4  
X:XX=±0.25
3. RATING:  
6A @250VAC;9A @125VAC (UL, CSA, VDE)  
4(1)A @250VAC
4. LAMP VOLTAGE: 250V (NEON BULB)
5. MATERIAL:  
CONTACT SURFACE: Coin Silver, Silver Plate  
TERMINAL: Copper Alloy w/ Silver Plate.
6. CONTACT RESISTANCE: 20mILLOHMS TYP. INITIAL
7. INSULATION RESISTANCE: 1000M@90OHMS
8. DIELECTRIC STRENGTH:  
>1500V RMS min. @SEA LEVEL  
>3000V RMS @SEA LEVEL
9. MECHANICAL LIFE: 50,000 CYCLES.
10. ELECTRICAL LIFE: 10,000 CYCLES.

**E-SWITCH®**

R1973A BLK RED EF2

REV.	ECN No.	DESCRIPTION	DATE	CHKD
A	11330	RELEASED FOR PRODUCTION	10/03/01	CJB

TITLE	SCALE	DATE	DR	DWG	REV
R1973A BLK RED EF2	1.5:1	10/3/01	CJB	M400026	A

THE INFORMATION CONTAINED IN THIS DOCUMENT IS PROPRIETARY TO E-SWITCH AND IS NOT TO BE COPIED OR TRANSMITTED