

Excellent Integrated System Limited

Stocking Distributor

Click to view price, real time Inventory, Delivery & Lifecycle Information:

[E-Switch](#)
[TL1107AF130BQ](#)

For any questions, you can email us directly:

sales@integrated-circuit.com

SHEET OF

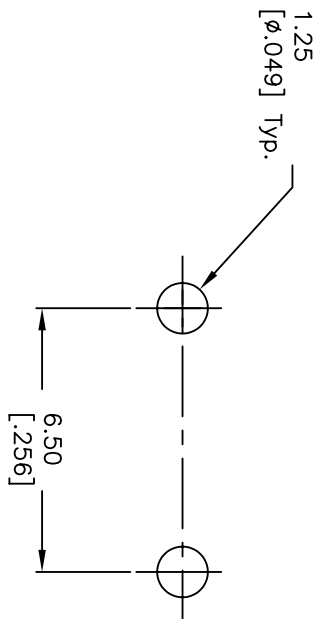
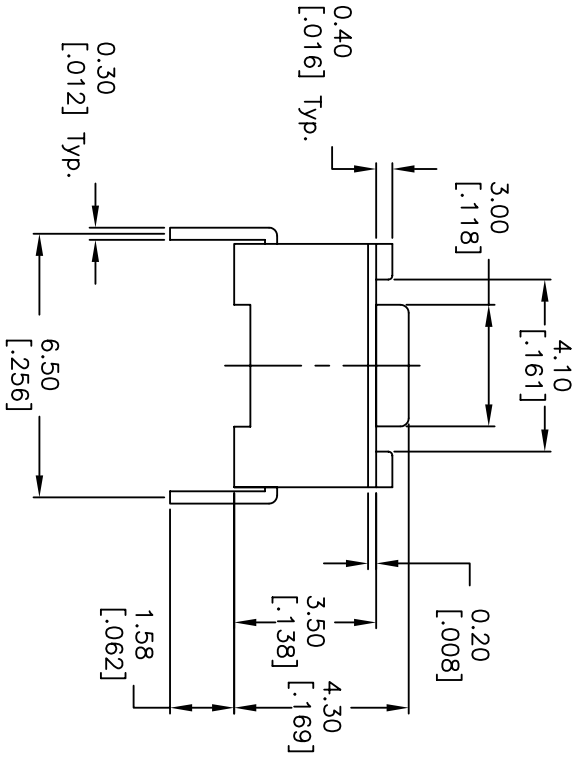
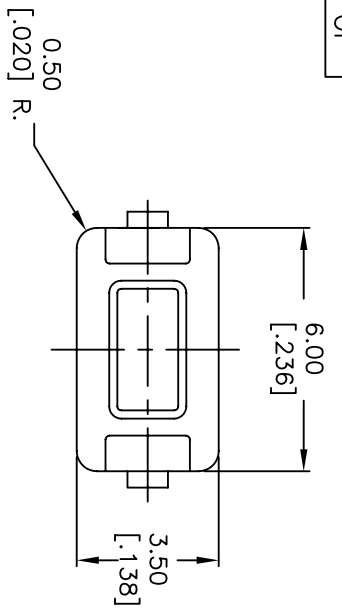

RECOMMEND P.C.B. LAYOUT

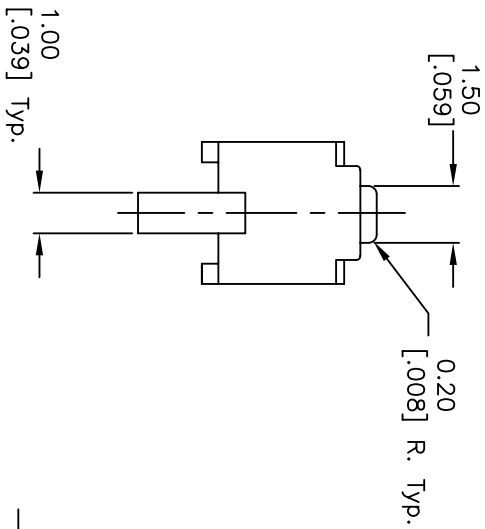

CIRCUIT: SPST
CONTACT CONFIGURATION

NOTES:

1. ALL DIMENSIONS IN MM [INCH]
2. GENERAL TOLERANCE: 0.0=±0.4
0.00=±0.25
3. TERM. NOS. FOR REF. ONLY
4. RATING: 50mA @12V DC
5. TRAVEL: 0.25±0.1mm
6. OPERATING FORCE: 130±50gf
7. CONTACT RESISTANCE: 100m ohm max.
8. MECHANICAL/ELECTRICAL LIFE: 40,000 CYCLES
9. PACKAGE: BULK, 1,000 PER BAG
10. 2002/95/EC (ROHS) COMPLIANT

REV.	ECN No.	DESCRIPTION	DATE	CHKD
B	16628	UPDATED NOTES	11/9/06	TN
A	10584	RELEASED FOR PRODUCTION	3/28/00	MM

THE INFORMATION CONTAINED IN THIS DOCUMENT IS PROPRIETARY TO E-SWITCH AND IS NOT TO BE COPIED OR TRANSMITTED



TITLE	SCALE	DATE	DR	DWG	REV
TL1107AF130BQ	5:1	11/9/2006	TN	P010380	B