

## Excellent Integrated System Limited

Stocking Distributor

Click to view price, real time Inventory, Delivery & Lifecycle Information:

[ON Semiconductor](#)  
[CAT885ZI-SA-GT3](#)

For any questions, you can email us directly:

[sales@integrated-circuit.com](mailto:sales@integrated-circuit.com)



# Five-Channel Power Supply Supervisors



## FEATURES

- Five-channel supply voltage detection
- 2  $V_{DD}$  inputs allow monitoring of +5.0V, +3.3V, +3.0V, +2.5V or +1.8V supplies
- 3 adjustable voltage inputs allow monitoring supplies > 0.6V
- 70ms minimum reset delay
- Manual reset capability
- Reset signals valid down to  $V_{DD} = 1V$
- Accurate  $\pm < 2\%$  voltage threshold
- Power-supply transients suppressed
- Low 2 $\mu$ A maximum supply current at 5V
- RoHS-compliant MSOP package

## APPLICATIONS

- Telecom & datacom systems
- Routers & servers
- Data storage equipment
- Set-top boxes
- Multi-voltage systems

## DESCRIPTION

The CAT885 is a five-channel power supply supervisory circuit with high reset threshold accuracy and very low power consumption. The device features an open-drain output, active-low function with manual reset to perform basic system reset and monitoring functions for a wide range of electronic products. The CAT885 monitors five system voltages by maintaining a reset output active until all the power supply voltages exceed the specified trip values. The device then maintains the reset output in an active condition until the internal timer times out, which allows the system power supplies to stabilize.

Two of the five voltage detectors are factory set for standard supplies, while the threshold voltages of the third, fourth, and fifth voltage monitors can be adjusted for specific system design requirements using external resistors.

The CAT885 lowers system costs and saves board space by integrating five channels into a single, small MSOP 8-lead package.

**For Ordering Information details see page 7.**

## PIN CONFIGURATION

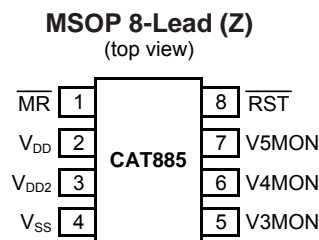

See page 2 for pin functions

## TYPICAL APPLICATION

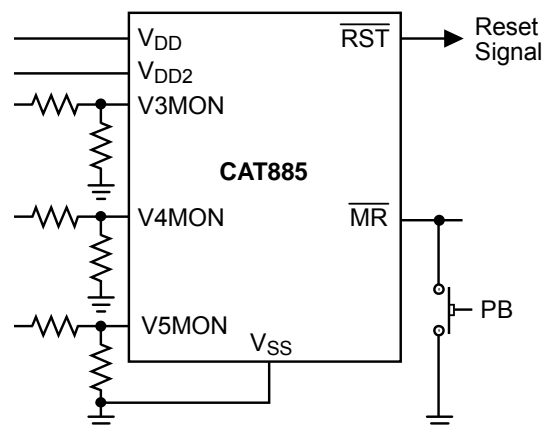

**CAT885**

**FUNCTIONAL BLOCK DIAGRAM**

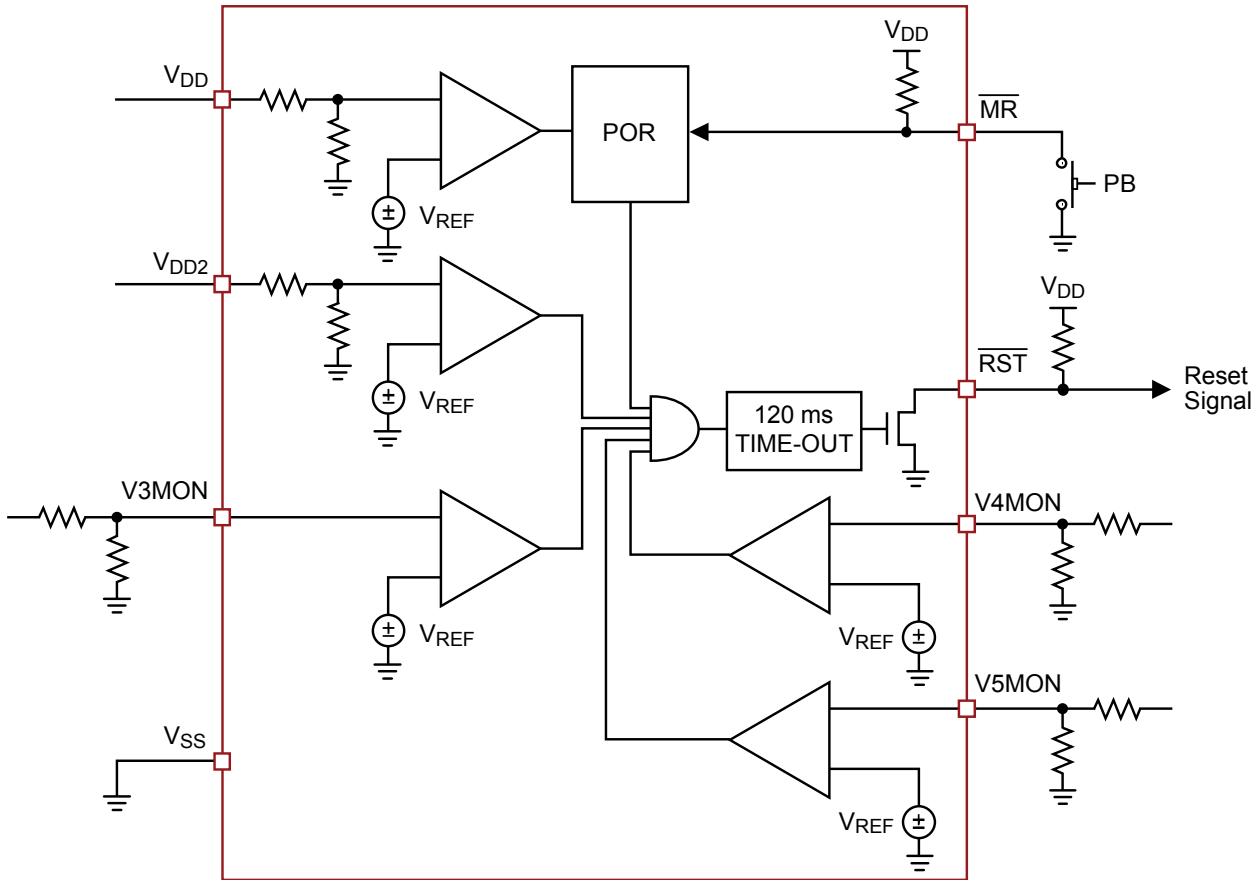

**PIN FUNCTIONS**

| Pin # | Pin              | Function   |
|-------|------------------|--|
| 1     | MR               | Active-low manual reset Input with internal pull-up resistor |
| 2     | V <sub>DD</sub>  | Chip supply, first preset under-voltage detector input       |
| 3     | V <sub>DD2</sub> | Second preset under-voltage detector input                   |
| 4     | V <sub>SS</sub>  | Ground   |
| 5     | V3MON            | Adjustable third under-voltage detector input                |
| 6     | V4MON            | Adjustable fourth under-voltage detector input               |
| 7     | V5MON            | Adjustable fifth under-voltage detector input                |
| 8     | RST              | Active-low open drain reset output, use external resistor    |

## ABSOLUTE MAXIMUM RATINGS<sup>(1)</sup>

| Parameters   | Ratings      | Units |
|--|--------------|-------|
| Temperature under Bias   | -40 to +125  | °C    |
| Voltage on any Pin with Respect to V <sub>SS</sub>               | -1.0 to +7.0 | V     |
| DC Output Current  | 5            | mA    |
| Thermal Resistance $\Theta_{JA}$ for MSOP Package <sup>(2)</sup> | 145          | °C/W  |

## RECOMMENDED OPERATING CONDITIONS

| Parameters                               | Ratings     | Units |
|--|-------------|-------|
| Operating Temperature Range (Industrial) | -40 to +85  | °C    |
| Storage Temperature                      | -65 to +150 | °C    |
| Lead Soldering Temperature (10 seconds)  | +300        | °C    |

## ELECTRICAL CHARACTERISTICS

Over the recommended operating conditions unless otherwise specified.

| Symbol                    | Parameter  | Conditions                        | Min   | Typ.  | Max   | Units |
|---------------------------|--|-----------------------------------|-------|-------|-------|-------|
| V <sub>DD</sub>           | Supply Voltage Range                             |                                   | 1.5   |       | 5.5   | V     |
| I <sub>DD1</sub>          | V <sub>DD</sub> Supply Current                   | V <sub>DD</sub> = 5.0V            |       | 2     | 9     | μA    |
| I <sub>DD2</sub>          | V <sub>DD2</sub> Input Current                   | V <sub>DD2</sub> = 3.3V           |       | 0.5   | 3     | μA    |
| I <sub>DDX</sub>          | V3, V4, V5MON Input Current                      | V3, V4, V5MON = 1.0V              |       | 15    | 50    | nA    |
| <b>Voltage Thresholds</b> |  |                                   |       |       |       |       |
| V <sub>TH1</sub>          | Fixed Voltage Trip Point for V <sub>DD</sub>     | CAT885Lx                          | 4.55  | 4.63  | 4.72  | V     |
|                           |  | CAT885Sx                          | 2.81  | 2.87  | 2.92  | V     |
| V <sub>TH1HYST</sub>      | Hysteresis of V <sub>TH1</sub>                   | V <sub>TH1</sub> = 4.63V          |       | 50    |       | mV    |
|                           |  | V <sub>TH1</sub> = 2.87V          |       | 30    |       | mV    |
| V <sub>TH2</sub>          | Fixed Voltage Trip Point for V <sub>DD2</sub>    | CAT885xT                          | 3.02  | 3.08  | 3.13  | V     |
|                           |  | CAT885xS                          | 2.90  | 2.95  | 3.01  | V     |
|                           |  | CAT885xZ                          | 2.29  | 2.33  | 2.37  | V     |
|                           |  | CAT885xA                          | 1.65  | 1.68  | 1.71  | V     |
| V <sub>TH2HYST</sub>      | Hysteresis of V <sub>TH2</sub>                   | V <sub>TH2</sub> = 3.08V          |       | 40    |       | mV    |
|                           |  | V <sub>TH2</sub> = 2.95V          |       | 30    |       | mV    |
|                           |  | V <sub>TH2</sub> = 2.33V          |       | 25    |       | mV    |
|                           |  | V <sub>TH2</sub> = 1.68V          |       | 20    |       | mV    |
| V <sub>REF</sub>          | V3MON, V4MON, V5MON Adj. Reset Threshold Voltage | V <sub>TH</sub> for V3, V4, V5MON | 0.585 | 0.598 | 0.611 | V     |
| V <sub>REFHYST</sub>      | Hysteresis Voltage                               |                                   |       | 3     |       | mV    |

### Notes:

- (1) Stresses above those listed under "Absolute Maximum Ratings" may cause permanent damage to the device. These are stress ratings only and functional operation of the devices at these or any other conditions outside of those listed in the operational sections of this specification is not implied. Exposure to any absolute maximum rating for extended periods may affect device performance and reliability.
- (2)  $\Theta_{JA}$  is measured with the component mounted on a high effective thermal conductivity test board in free air.

## CAT885

### ELECTRICAL CHARACTERISTICS (continued)

| Symbol              | Parameter                                  | Conditions                            | Min                   | Typ. | Max  | Units |
|---------------------|--|---------------------------------------|-----------------------|------|------|-------|
| <b>Reset</b>        |  |                                       |                       |      |      |       |
| V <sub>OL</sub>     | Reset Output Voltage Low                   | V <sub>DD</sub> ≥ 3.3V, Sinking 2.5mA |                       | 0.05 | 0.40 | V     |
|                     |  | V <sub>DD</sub> < 3.3V, Sinking 1.5mA |                       | 0.05 | 0.40 | V     |
| t <sub>RPD</sub>    | V <sub>TH</sub> to Reset Asserted Delay    |                                       | 1                     | 6    |      | μs    |
| t <sub>PD</sub>     | POR Timeout Delay                          |                                       | 70                    | 120  | 240  | ms    |
| C <sub>LOAD</sub>   | Load Capacitance on Reset Pin              |                                       |                       | 5    |      | pF    |
| <b>Manual Reset</b> |  |                                       |                       |      |      |       |
| V <sub>THL</sub>    | $\overline{\text{MR}}$ Input Voltage Low   |                                       |                       |      | 0.8  | V     |
| V <sub>THH</sub>    | $\overline{\text{MR}}$ Input Voltage High  |                                       | V <sub>DD</sub> - 0.6 |      |      | V     |
| T <sub>PW</sub>     | $\overline{\text{MR}}$ Minimum Pulse Width |                                       | 1                     |      |      | μs    |
| R <sub>IN</sub>     | Internal Pull-Up Resistor                  |                                       | 8                     |      | 16   | kΩ    |

### OPERATION

The CAT885 is designed to monitor critical supply voltages in line driven and battery powered microprocessor systems, providing Supply Voltage Supervision, Power On Reset control and Manual Reset Assertion. These features along with excellent threshold accuracy and low power consumption make the CAT885 device suitable for a wide variety of applications needing multi-voltage monitoring.

During normal operation, the CAT885 monitors the voltage levels of V<sub>DD</sub>, V<sub>2MON</sub>, V<sub>3MON</sub>, V<sub>4MON</sub>, and V<sub>5MON</sub>. If the voltage on any of these five inputs falls below their respective voltage trip points, a reset is asserted (RST = low) to prevent the microprocessor from operating during a power failure or brownout condition. This reset signal remains low until the voltages exceeds the voltage threshold settings for the reset time delay period t<sub>PD</sub>.

CAT885 allows users to adjust the minimum voltage sense level for three of the five monitored voltages. For example, the user can adjust the voltage input trip point for V<sub>3MON</sub>, V<sub>4MON</sub> and V<sub>5MON</sub> inputs. This is done by connecting an external resistor divider network to the V<sub>xMON</sub> pin in order to set the trip point to a voltage above 600mV. Resistors R<sub>1</sub> and R<sub>2</sub> in Figure 1 are selected by the formula:  $V_{\text{TRIP}} = 0.6V \times (R_1 + R_2) / R_2$ .

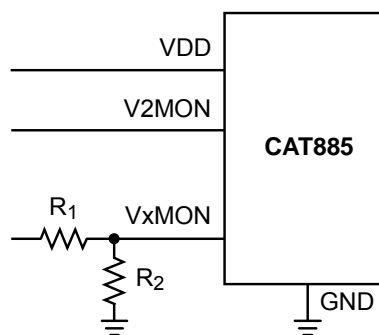

Figure 1. CAT885 Programming Trip Voltage

**POWER ON RESET (POR)**

Applying power to the CAT885 activates a POR circuit which activates the reset output (active LOW). At power-up POR prevents the system microprocessor from starting to operate with insufficient voltage and prior to stabilization of the clock oscillator. It ensures that operation is precluded until internal registers are properly loaded, FPGA's have downloaded their configuration data prior and all system power supplies are above minimum operating levels and stable. The reset signal remains active until  $V_{DD}$  rises above the minimum preset voltage level for time period  $t_{PD}$ .

**MANUAL RESET**

The manual-reset input ( $\overline{MR}$ ) allows the user to trigger a reset by using a push-button switch or by electronically driving the input low. The  $\overline{MR}$  input is an active LOW debounced input. Reset is asserted anytime the  $\overline{MR}$  pin is pulled low to less than 100mV for the minimum  $\overline{MR}$  pulse width or longer. The reset output remains asserted low for  $t_{PD}$ , typically 120ms and then is released. Figures 2 and 3 illustrate the CAT885's operation and  $\overline{RST}$  output response times.

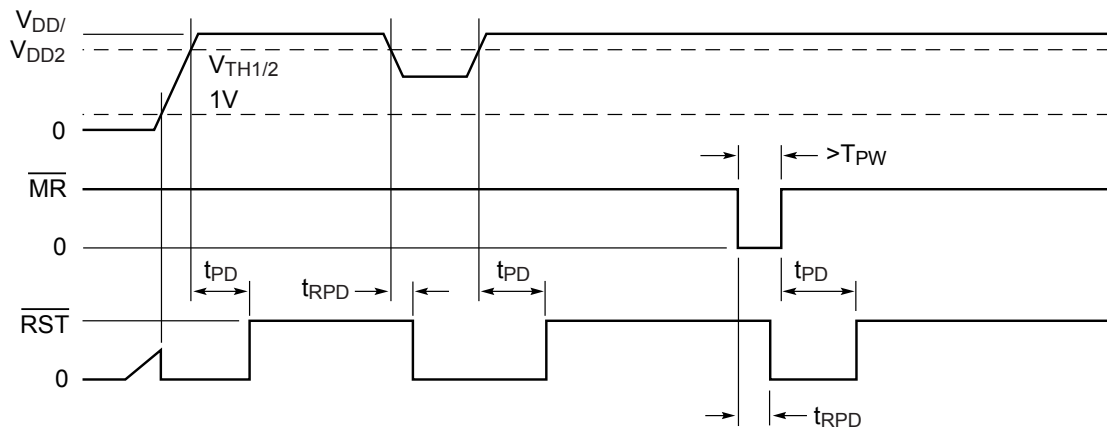

**Figure 2. Power Supply Monitoring Diagram**

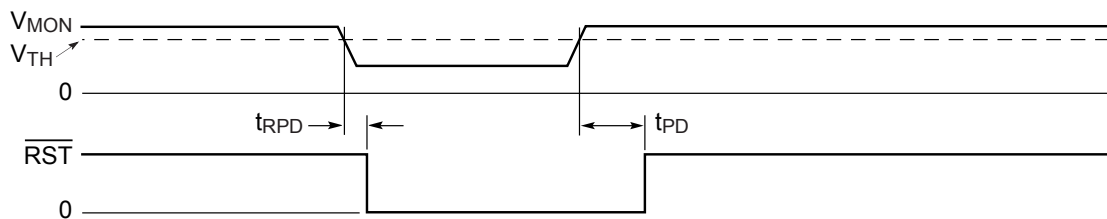
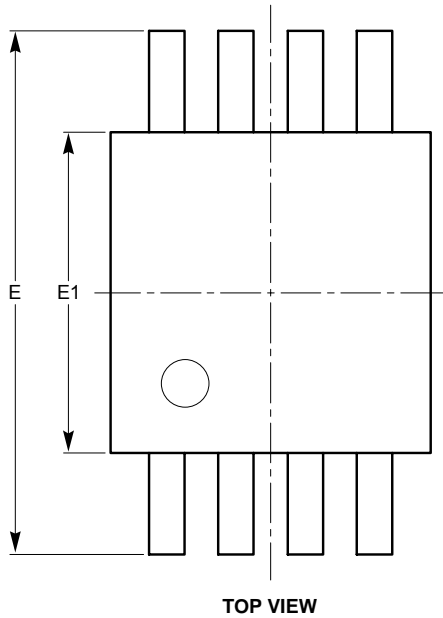

**Figure 3. Auxillary Voltage Monitoring Diagram**

## CAT885

### PACKAGE OUTLINE DRAWING

MSOP 8-Lead 3 x 3mm (Z) <sup>(1)(2)</sup>



| SYMBOL | MIN      | NOM  | MAX  |
|--------|----------|------|------|
| A      |          |      | 1.10 |
| A1     | 0.05     | 0.10 | 0.15 |
| A2     | 0.75     | 0.85 | 0.95 |
| b      | 0.22     |      | 0.38 |
| c      | 0.13     |      | 0.23 |
| D      | 2.90     | 3.00 | 3.10 |
| E      | 4.80     | 4.90 | 5.00 |
| E1     | 2.90     | 3.00 | 3.10 |
| e      | 0.65 BSC |      |      |
| L      | 0.40     | 0.60 | 0.80 |
| L1     | 0.95 REF |      |      |
| L2     | 0.25 BSC |      |      |
| θ      | 0°       |      | 6°   |

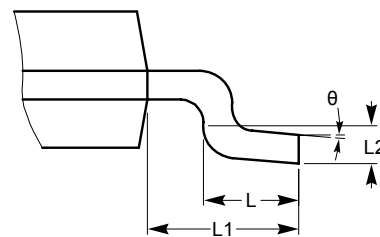
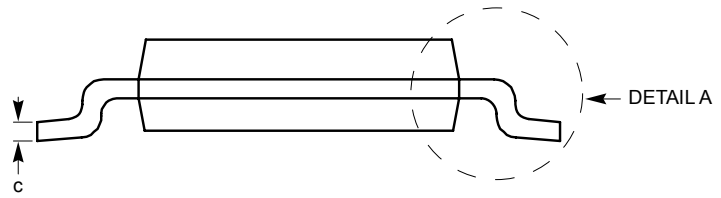
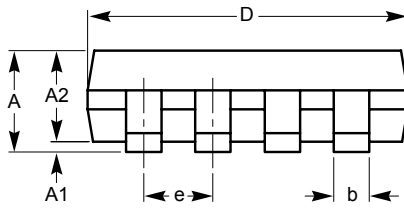

**Notes:**

(1) All dimensions are in millimeters. Angles in degrees.

(2) Complies with JEDEC standard MO-187.

**EXAMPLE OF ORDERING INFORMATION**

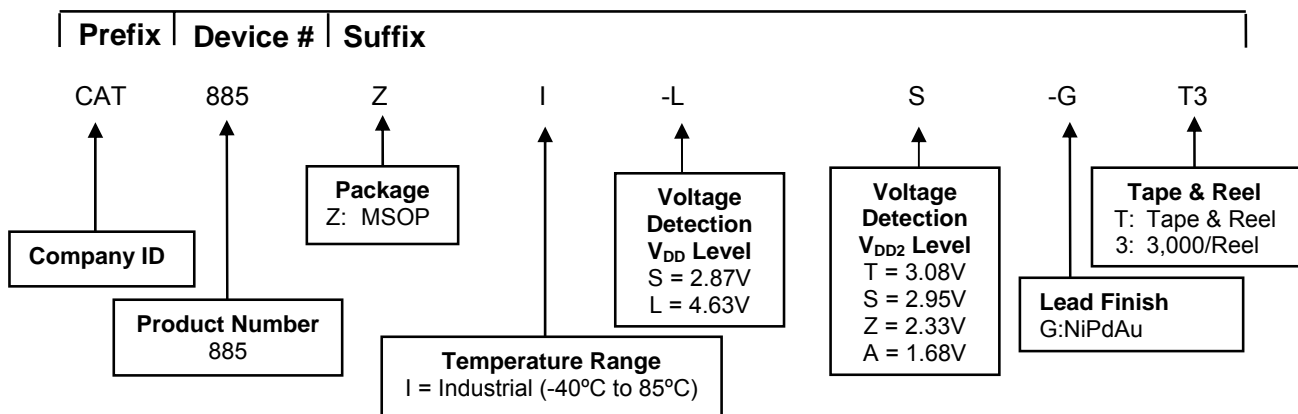

**ORDERING INFORMATION**

| Part Number     | V <sub>DD</sub> | V <sub>DD2</sub> | Package |
|-----------------|-----------------|------------------|---------|
| CAT885ZI-ST-GT3 | 2.87V           | 3.08V            | MSOP    |
| CAT885ZI-SS-GT3 | 2.87V           | 2.95V            | MSOP    |
| CAT885ZI-SZ-GT3 | 2.87V           | 2.33V            | MSOP    |
| CAT885ZI-SA-GT3 | 2.87V           | 1.68V            | MSOP    |
| CAT885ZI-LT-GT3 | 4.63V           | 3.08V            | MSOP    |
| CAT885ZI-LS-GT3 | 4.63V           | 2.95V            | MSOP    |
| CAT885ZI-LZ-GT3 | 4.63V           | 2.33V            | MSOP    |
| CAT885ZI-LA-GT3 | 4.63V           | 1.68V            | MSOP    |

**Notes:**

- (1) All packages are RoHS-compliant (Lead-free, Halogen-free).
- (2) The standard finish is NiPdAu.
- (3) The device used in the above example is a CAT885ZI-LS-GT3 (MSOP, Industrial Temperature, 4.63V (V<sub>DD</sub>) and 2.95V (V<sub>DD2</sub>) Detection Levels, NiPdAu, Tape & Reel, 3,000/Reel).
- (4) For additional detection voltage, package and temperature options, please contact your nearest ON Semiconductor Sales office.



## CAT885

### REVISION HISTORY

| Date      | Rev. | Description                                    |
|-----------|------|--|
| 05-May-08 | A    | Initial Release                                |
| 06-Nov-08 | B    | Change logo and fine print to ON Semiconductor |
| 03-Aug-09 | C    | Update Functional Block Diagram                |

ON Semiconductor and  are registered trademarks of Semiconductor Components Industries, LLC (SCILLC). SCILLC reserves the right to make changes without further notice to any products herein. SCILLC makes no warranty, representation or guarantee regarding the suitability of its products for any particular purpose, nor does SCILLC assume any liability arising out of the application or use of any product or circuit, and specifically disclaims any and all liability, including without limitation special, consequential or incidental damages. "Typical" parameters which may be provided in SCILLC data sheets and/or specifications can and do vary in different applications and actual performance may vary over time. All operating parameters, including "Typicals" must be validated for each customer application by customer's technical experts. SCILLC does not convey any license under its patent rights nor the rights of others. SCILLC products are not designed, intended, or authorized for use as components in systems intended for surgical implant into the body, or other applications intended to support or sustain life, or for any other application in which the failure of the SCILLC product could create a situation where personal injury or death may occur. Should Buyer purchase or use SCILLC products for any such unintended or unauthorized application, Buyer shall indemnify and hold SCILLC and its officers, employees, subsidiaries, affiliates, and distributors harmless against all claims, costs, damages, and expenses, and reasonable attorney fees arising out of, directly or indirectly, any claim of personal injury or death associated with such unintended or unauthorized use, even if such claim alleges that SCILLC was negligent regarding the design or manufacture of the part. SCILLC is an Equal Opportunity/Affirmative Action Employer. This literature is subject to all applicable copyright laws and is not for resale in any manner.

#### PUBLICATION ORDERING INFORMATION

##### LITERATURE FULFILLMENT:

**Literature Distribution Center for ON Semiconductor**  
P.O. Box 5163, Denver, Colorado 80217 USA  
**Phone:** 303-675-2175 or 800-344-3860 Toll Free USA/Canada  
**Fax:** 303-675-2176 or 800-344-3867 Toll Free USA/Canada  
**Email:** orderlit@onsemi.com

**N. American Technical Support:** 800-282-9855 Toll Free  
USA/Canada

**Europe, Middle East and Africa Technical Support:**  
Phone: 421 33 790 2910

**Japan Customer Focus Center:**  
Phone: 81-3-5773-3850

**ON Semiconductor Website:** [www.onsemi.com](http://www.onsemi.com)

**Order Literature:** <http://www.onsemi.com/orderlit>

For additional information, please contact your local Sales Representative