

Excellent Integrated System Limited

Stocking Distributor

Click to view price, real time Inventory, Delivery & Lifecycle Information:

[Maxim Integrated](#)
[MAX11504EVKIT+](#)

For any questions, you can email us directly:

sales@integrated-circuit.com

MAXIM

MAX11504 Evaluation Kit

General Description

The MAX11504 evaluation kit (EV kit) is a fully assembled and tested surface-mount printed-circuit board (PCB) that contains a MAX11504 IC. The MAX11504 is a 4-channel video reconstruction filter and buffer for standard-definition television (SDTV) applications. The filter's passband is typically 8.6MHz. The MAX11504 includes a +6dB output buffer capable of driving 2V_{P-P} into two standard 150Ω loads.

The video input and output signals on the EV kit can be AC- or DC-coupled. The MAX11504 video input terminals are terminated at 75Ω and the output terminals are 75Ω back terminated. The EV kit operates from a single 5V DC power supply. The MAX11504 EV kit can also evaluate the MAX11505 IC. Request a free MAX11505 IC sample from the factory when ordering the MAX11504 EV kit.

Features

- ◆ Single 5V Supply Operation
- ◆ Output Buffer Drives Two 150Ω Standard Video Loads with a +6dB Gain
- ◆ Four Standard-Definition Television Video Filters
- ◆ AC- or DC-Coupled Inputs and Outputs
- ◆ Standard 75Ω Input/Output Terminations
- ◆ Also Evaluates the MAX11505 (After IC Replacement)
- ◆ Surface-Mount Components
- ◆ Fully Assembled and Tested

Ordering Information

PART	TYPE
MAX11504EVKIT+	EV Kit

+Denotes lead-free and RoHS-compliant.

Component List

DESIGNATION	QTY	DESCRIPTION
C1	1	1μF ±10%, 6.3V X5R ceramic capacitor (0603) Murata GRM188R60J105K TDK C1608X5R0J105K
C2-C6, C12-C15	9	0.1μF ±10%, 16V X7R ceramic capacitors (0603) Murata GRM188R71C104K TDK C1608X7R1C104KT
C7-C11	5	220μF ±20%, 6.3V aluminum electrolytic capacitors (6.3 x 6.0) SANYO 6CE220AX
IN_1-IN_4, OUT_1A, OUT_1B, OUT_2, OUT_3, OUT4	9	75Ω BNC PCB-mount connectors

DESIGNATION	QTY	DESCRIPTION
IN1-IN4, OUT1-OUT4	8	Test points
JU1-JU16	16	2-pin headers
R1-R9	9	75Ω ±1% resistors (0603)
R10, R11, R12	3	150Ω ±1% resistors (0603)
R13-R16	4	820kΩ ±5% resistors (0603)
R17-R20	4	120kΩ ±5% resistors (0603)
U1	1	Four-channel, standard-definition video filter (10-pin μMAX®) Maxim MAX11504CUB+
—	16	Shunts
—	1	PCB: MAX11504 Evaluation Kit+

Component Suppliers

SUPPLIER	PHONE	WEBSITE
Murata Mfg. Co., Ltd.	770-436-1300	www.murata.com
SANYO North America Corp.	619-661-6835	www.sanyodevice.com
TDK Corp.	847-803-6100	www.component.tdk.com

Note: Indicate that you are using the MAX11504 or MAX11505 when contacting these component suppliers.

μMAX is a registered trademark of Maxim Integrated Products, Inc.

MAX11504 Evaluation Kit

Quick Start

Recommended Equipment

Before beginning, the following equipment is needed:

- 5V, 150mA DC power supply (VCC)
- Video signal generator (e.g., Tektronix TG-2000 or similar)
- Video measurement equipment (e.g., Tektronix VM700T or similar)

Procedure

The MAX11504 EV kit is fully assembled and tested. Follow the steps below to verify board operation.

Caution: Do not turn on the power supply until all connections are completed.

- 1) Verify that no shunts are installed across jumpers JU1–JU4 (AC-coupled inputs).
- 2) Verify that no shunts are installed across jumpers JU5–JU8 (no DC bias input).
- 3) Verify that no shunts are installed across jumpers JU9, JU10, JU11 (one video load).
- 4) Verify that no shunts are installed across jumpers JU12–JU16 (AC-coupled outputs).
- 5) Connect the output of the video signal generator to the IN_1 BNC connector on the MAX11504 EV kit.
- 6) Connect the OUT_1A BNC connector on the EV kit to the input of the video measurement equipment.
- 7) Connect the power-supply ground to the GND pad on the EV kit.
- 8) Connect the 5V supply to the VCC pad on the EV kit.
- 9) Set the video signal generator for the desired video input signal. Since the input is AC-coupled and not biased, the signal should be a unipolar signal such as R, G, B, or Y.
- 10) Turn on the power supply, and enable the video signal generator.
- 11) Analyze the video output signal.

Detailed Description of Hardware

The MAX11504 EV kit is a fully assembled and tested surface-mount PCB that contains a MAX11504 IC. The MAX11504 is a four-channel video reconstruction filter and buffer for SDTV applications. The MAX11504 filter typically has 3dB attenuation at 8.6MHz and 50dB attenuation at 27MHz. The device includes a +6dB output buffer capable of driving a 2V_{p-p} video signal into two standard 150Ω loads.

The MAX11504 EV kit has four input channels to accept composite and component video input signals. Each output from the MAX11504 EV kit is capable of driving a 75Ω load to ground. This is equivalent to driving two sets of 150Ω loads in parallel to ground.

All the input and output signals on the MAX11504 EV kit can be configured for AC- or DC-coupling. The EV kit's input terminals are 75Ω terminated and the video output terminals are each back terminated with 75Ω.

MAX11505 Evaluation

The MAX11504 EV kit can also evaluate the MAX11505 IC. To evaluate the MAX11505, replace the IC (U1) with the MAX11505 IC. Refer to the MAX11505 IC data sheet for additional information.

Jumper Selection

Input Coupling

The MAX11504 IC features a transparent clamp at the video inputs that allows either AC- or DC-coupling. If the input signal remains above ground, the transparent clamp is inactive, offering true DC input coupling. If the signal drops below ground, the inputs must be AC-coupled. The transparent clamp will set the sync tip just below ground.

The MAX11504 EV kit provides an option to configure the MAX11504 inputs to AC- or DC-coupling. Jumpers JU1–JU4 configure the input coupling for the MAX11504 EV kit. See Table 1 for shunt positions.

Table 1. JU1–JU4 Jumper Selection

SHUNT POSITION	COUPLING CONFIGURATION
Installed	DC-coupling
Not installed*	AC-coupling

*Default position.

MAX11504 Evaluation Kit

Output Coupling

The MAX11504 EV kit provides an option to configure the MAX11504 outputs to AC- or DC-coupling. Jumpers JU12–JU16 configure the output coupling for the MAX11504 EV kit. See Table 2 for shunt positions.

Table 2. JU12–JU16 Jumper Selection

SHUNT POSITION	COUPLING CONFIGURATION
Installed	DC-coupling
Not installed*	AC-coupling

*Default position.

Output Channel 2, 3, and 4 Load (OUT_2, OUT_3, OUT_4)

The MAX11504 EV kit provides an option to fully load the output channels (2, 3, and 4) of the MAX11504. Jumpers JU9, JU10, and JU11 configure channel 2, channel 3, and channel 4 output loads, respectively, on the MAX11504 EV kit. See Table 3 for shunt positions.

Table 3. JU9, JU10, JU11 Jumper Selection (OUT_2, OUT_3, OUT_4)

SHUNT POSITION	OUTPUT LOAD (Ω)
Installed	75
Not installed*	150

*Default position.

DC Bias for YPbPr Signals

When configuring the EV kit video inputs for AC-coupled operation, the correct DC bias point has to be chosen, depending on the input signal. Unipolar signals, such as R, G, B, and Y, are biased correctly using the MAX11504 internal transparent clamp. For bipolar signals, such as P_B and P_R, a constant DC bias voltage has to be applied after the AC-coupling capacitor to make sure that the clamp never operates. A 590mV DC bias voltage can be applied by installing shunts across jumpers JU5–JU8. To configure the inputs to a different DC bias voltage, replace resistors R17–R20. See Table 4 for input clamp configuration.

Table 4. Input Clamp Operation (JU5–JU8)

SHUNT POSITION	EV KIT FUNCTION
Installed	DC bias enabled: Use for Pb, Pr signals
Not installed*	DC bias disabled: Use for R, G, B, Y signals

*Default position.

Evaluates: MAX11504/MAX11505

MAX11504 Evaluation Kit

Evaluates: MAX11504/MAX11505

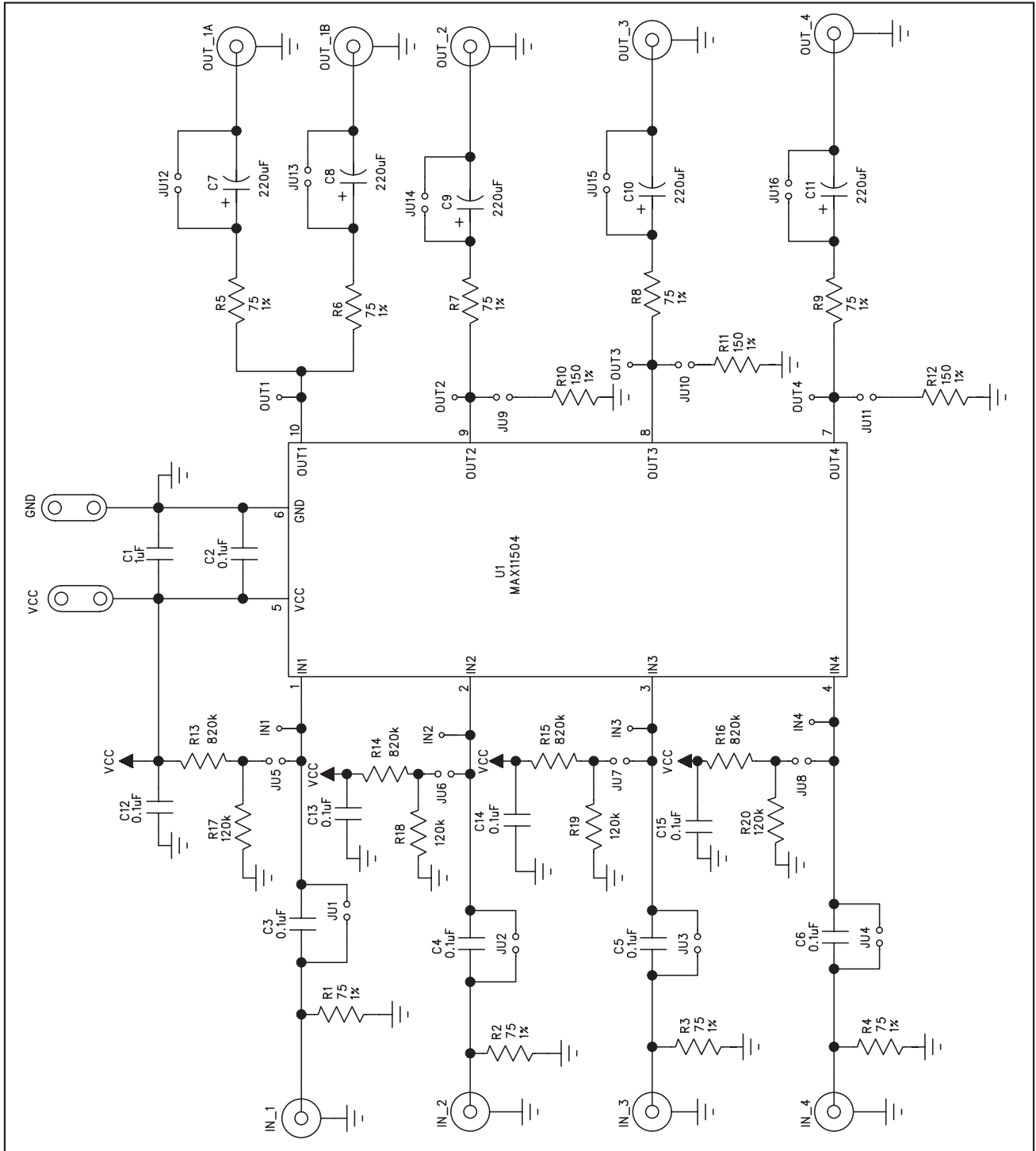

Figure 1. MAX11504 EV Kit Schematic

MAX11504 Evaluation Kit

Evaluates: MAX11504/MAX11505

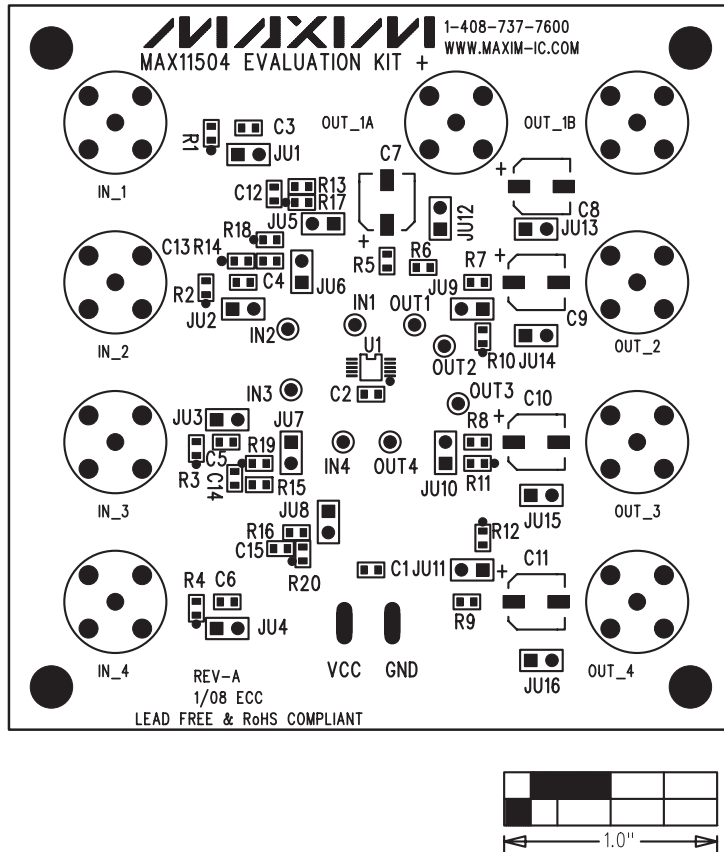

Figure 2. MAX11504 EV Kit Component Placement Guide—Component Side

MAX11504 Evaluation Kit

Evaluates: MAX11504/MAX11505

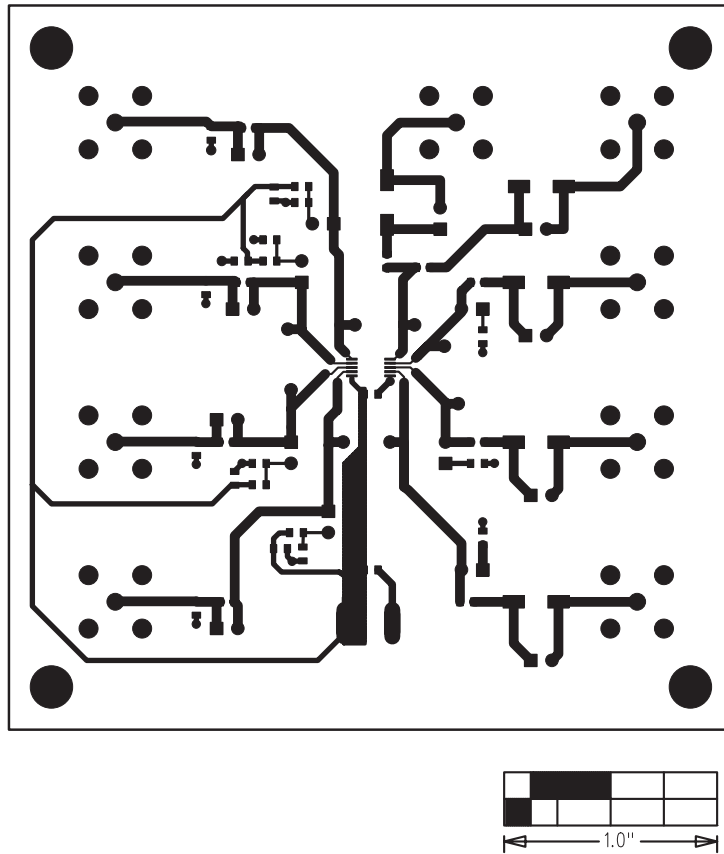

Figure 3. MAX11504 EV Kit PCB Layout—Component Side

MAX11504 Evaluation Kit

Evaluates: MAX11504/MAX11505

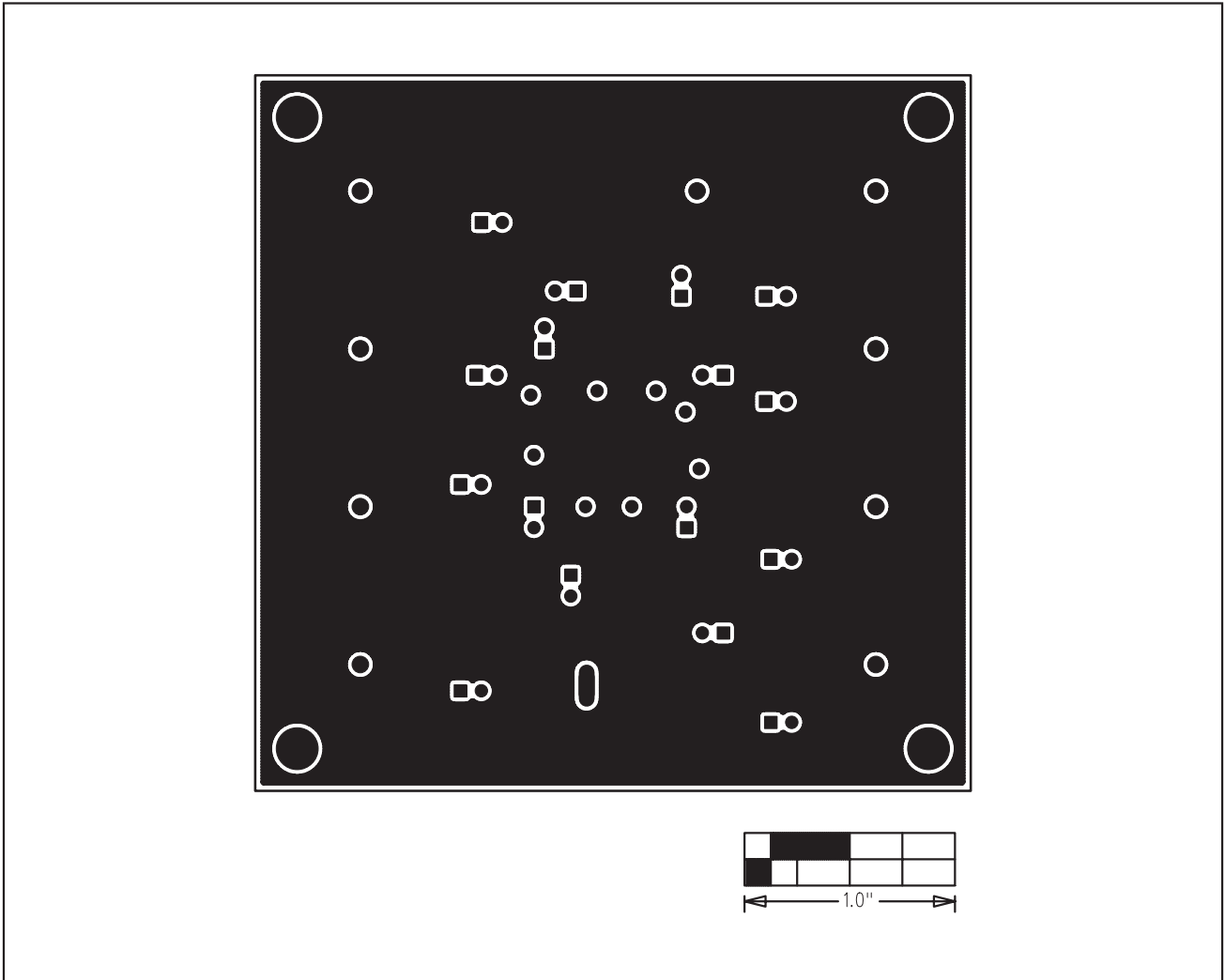

Figure 4. MAX11504 EV Kit PCB Layout—Solder Side

Maxim cannot assume responsibility for use of any circuitry other than circuitry entirely embodied in a Maxim product. No circuit patent licenses are implied. Maxim reserves the right to change the circuitry and specifications without notice at any time.

Maxim Integrated Products, 120 San Gabriel Drive, Sunnyvale, CA 94086 408-737-7600 _____ **7**