

Excellent Integrated System Limited

Stocking Distributor

Click to view price, real time Inventory, Delivery & Lifecycle Information:

[Newhaven Display Intl](#)
[NHD-C12864WM-09-FSW-FBW-3V3](#)

For any questions, you can email us directly:

sales@integrated-circuit.com

NHD-C12864WM-09-FSW-FBW-3V3

COG (Chip-On-Glass) Liquid Crystal Display Module

NHD-	Newhaven Display
C12864-	128 x 64 pixels
WM-	Model
F-	Transflective
SW-	Side White LED backlight
F-	FSTN (+)
B-	6:00 view
W-	Wide Temp (-20°C ~ +70°C)
3V3-	3Vdd, 3Volt Backlight
	RoHS Compliant

Newhaven Display International, Inc.

2511 Technology Drive, Suite 101

Elgin IL, 60124

Ph: 847-844-8795

Fax: 847-844-8796

www.newhavendisplay.com

nhtech@newhavendisplay.com

nhsales@newhavendisplay.com

Document Revision History

Revision	Date	Description	Changed by
0	1/22/2007	Initial Release	-
1	9/23/2009	User guide reformat	BE
2	10/13/2009	Updated Electrical Characteristic	MC
3	4/22/2010	Mechanical Drawing Update	MP
4	7/9/2010	Block diagram updated	BE

Functions and Features

- 128 x 64 pixels
- Built-in SPLC501C controller
- Parallel or Serial interface
- 1/64 duty cycle; 1/9 bias
- RoHS Compliant

Mechanical Drawing

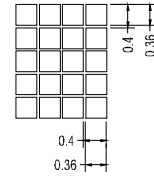
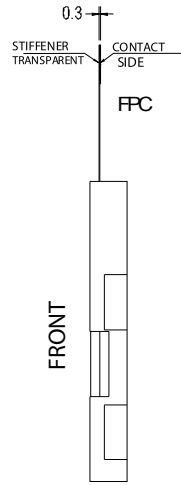
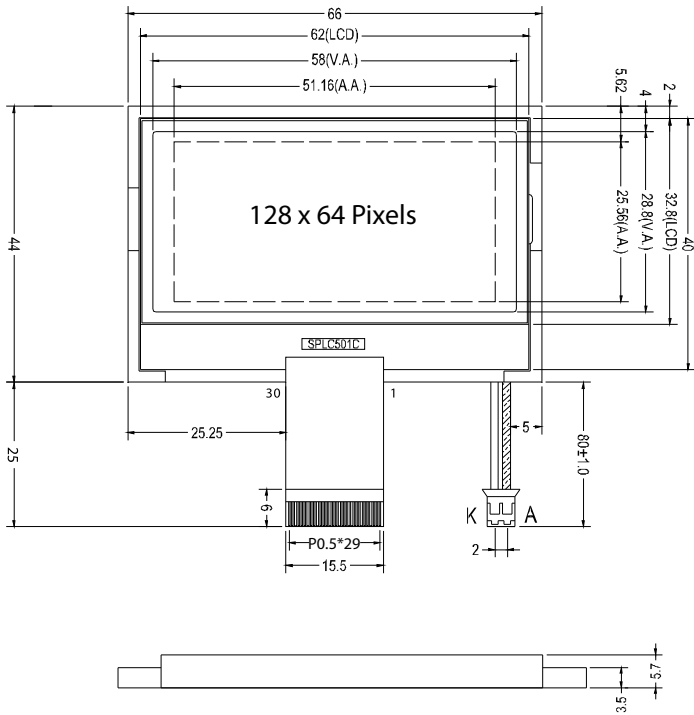

TOLERANCES UNLESS OTHERWISE STATED
 .X ±0.20
 ANGLES±1°
 ALL DIMENSIONS IN MM

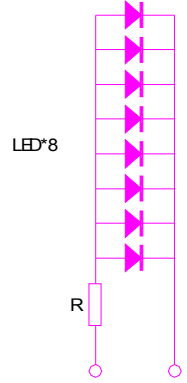

Note: Lifetime>50'000hours

GENERAL SPECIFICATIONS

LCD TYPE	<input type="checkbox"/> TN <input type="checkbox"/> HTN <input type="checkbox"/> STN <input checked="" type="checkbox"/> FSTN
	<input type="checkbox"/> REFLECTIVE
POLARIZER MODE	<input checked="" type="checkbox"/> TRANSPARENT
	<input type="checkbox"/> TRANSMISSIVE
DISPLAY COLOR	<input type="checkbox"/> YELLOW <input type="checkbox"/> GRAY <input type="checkbox"/> BLUE
VIEWING ANGLE	<input checked="" type="checkbox"/> 6 O'CLOCK <input type="checkbox"/> 12 O'CLOCK
BACKLIGHT	<input type="checkbox"/> BACK <input checked="" type="checkbox"/> SIDE <input type="checkbox"/> EL <input type="checkbox"/> CCFL
BACKLIGHT COLOR	<input type="checkbox"/> Y-G <input checked="" type="checkbox"/> WHT <input type="checkbox"/> GREEN <input type="checkbox"/> BLUE
TEMPERATURE RANGE	<input type="checkbox"/> STANDARD <input checked="" type="checkbox"/> WIDE

ELECTRICAL CHARACTERISTICS

ITEM	SYMBOL	CONDITION	MIN	MAX	UNIT
Supply voltage	VDD	-	2.4	5.5	V
Supply current	IDD	VDD=3.3V	0.6	1.0	mA
Driving voltage	V _{LCD}	-	-	9.5	V
Driving current	I _{EE}	V _{LCD} =9.5V	8	20	µA
LED BKL voltage	V _{LED}	-	3.0	4.0	V
LED BKL current	I _F	V _{LED} =4.0	40	50	mA

PIN CONNECTIONS

PIN	SIGNAL	PIN	SIGNAL	PIN	SIGNAL	PIN	SIGNAL
1	CS2	10	DB4	19	CAP2N	28	VR
2	RESETB	11	DB5	20	CAP2P	29	C86
3	RS	12	DB6	21	VSS	30	PS
4	RAV	13	DB7	22	VDD		
5	E	14	VSS2	23	V1		
6	DB0	15	VOUT	24	V2		
7	DB1	16	CAP3N	25	V3		
8	DB2	17	CAP1P	26	V4		
9	DB3	18	CAP1N	27	V5		

Newhaven Display

Model Name:

NHD-C12864WM-09-FSW-FBW-3V3

DATE: 9/23/2009

SHEET: 1-1

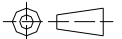

Pin Description and Wiring Diagram

Pin No.	Symbol	External Connection	Function Description
1	CS2	MPU	Active HIGH chip select
2	RESETB	MPU	Active LOW Reset signal
3	RS	MPU	Register select signal. RS=0: Command, RS=1: Data
4	RW	MPU	Read/write select signal. R/W=1: Read R/W=0: Write
5	E	MPU	Operation enable signal. Falling edge triggered.
6	DB0	MPU	Parallel Interface DB0-DB7: Bi-directional 8-bit data bus
7	DB1	MPU	
8	DB2	MPU	
9	DB3	MPU	
10	DB4	MPU	
11	DB5	MPU	
12	DB6	MPU	
13	DB7	MPU	Serial Interface: DB0-DB5: No connect in serial mode DB6= Serial clock (CLK) DB7= Serial data input (SDA)
14	VSS2	Power Supply	GND (reference for voltage step-up circuit)
15	VOUT	Power Supply	Connect to 1uF cap to VSS2 (PIN-14)
16	CAP3-	Power Supply	Connect to 1uF cap to CAP1+ (PIN-17)
17	CAP1+	Power Supply	Connect to 1uF cap to CAP3-(PIN16) and CAP1-(PIN18)
18	CAP1-	Power Supply	Connect to 1uF cap to CAP1+ (PIN-17)
19	CAP2-	Power Supply	Connect to 1uF cap to CAP2+ (PIN-20)
20	CAP2+	Power Supply	Connect to 1uF cap to CAP2- (PIN-19)
21	VSS	Power Supply	Ground
22	VDD	Power Supply	Power supply for LCD and logic (3.0V)
23	V1	Power Supply	1.0uF-2.2uF cap to VDD
24	V2	Power Supply	1.0uF-2.2uF cap to VDD
25	V3	Power Supply	1.0uF-2.2uF cap to VDD
26	V4	Power Supply	1.0uF-2.2uF cap to VDD
27	V5	Power Supply	1.0uF-2.2uF cap to VDD
28	VR	-	No Connect
29	C86	MPU	Select MPU interface pin. C86=H: 6800; C86=L: 8080
30	PS	MPU	Parallel/Serial select. PS= H: Parallel; PS=L: Serial
A		Power Supply	Power supply for LED Backlight (+3.0V)
K		Power Supply	Ground for Backlight

Recommended LCD connector: 0.5mm Pitch, 30 pin FFC. Molex p/n: 52892-3095

Backlight connector: A2001H-2P **Mates with:** A2001WR-S-2P

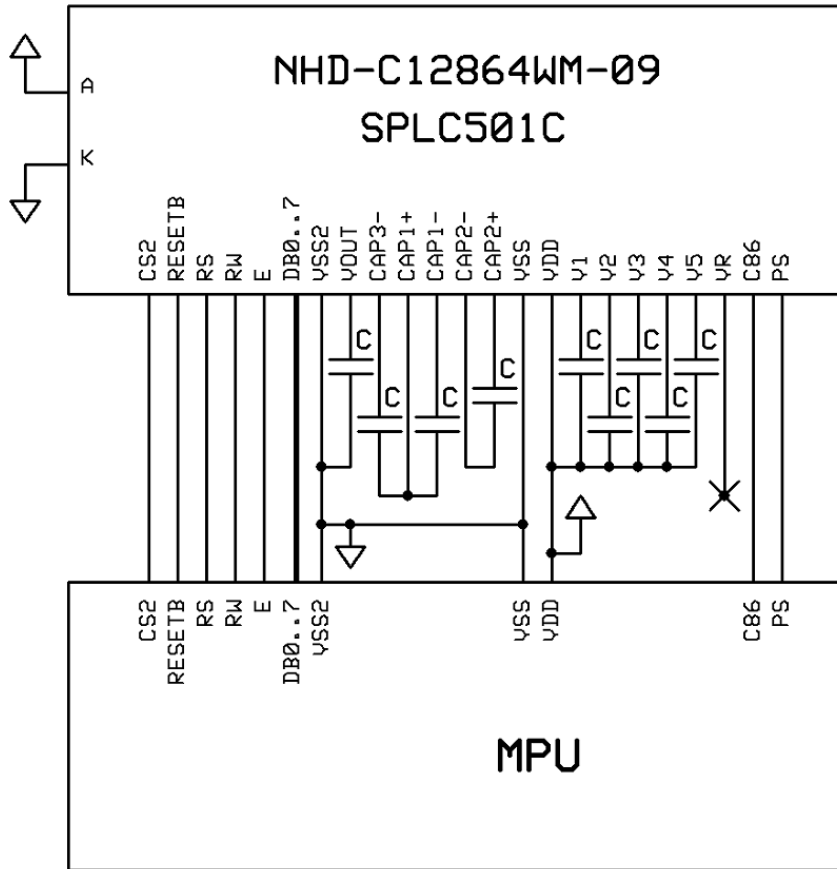

Electrical Characteristics

Item	Symbol	Condition	Min.	Typ.	Max.	Unit
Operating Temperature Range	TOP	Absolute Max	-20	-	+70	°C
Storage Temperature Range	TST	Absolute Max	-30	-	+80	°C
Supply Voltage	VDD		2.4	3.3	5.5	V
Supply Current	IDD	VDD=3.3v	0.6	-	1.0	mA
Supply for LCD (contrast)	VDD-V0	-	-	-	9.5	V
"H" Level input	Vih		0.7VDD	-	VDD	V
"L" Level input	Vil		Vss	-	0.3VDD	V
"H" Level output			-	-	-	-
"L" Level output			-	-	-	-
LED BKL voltage	VLED	-	-	3.0	-	V
LED BKL current	ILED	VLED=3.0	40	-	50	mA

Optical Characteristics

Item	Symbol	Condition	Min.	Typ.	Max.	Unit
Viewing Angle - Vertical	θ	CR \geq 2	-60	-	+35	°
Viewing Angle - Horizontal	Φ	CR \geq 2	-40	-	+40	°
Contrast Ratio	CR		-	6	-	-
Response Time (rise)	Tr		-	150	250	ms
Response Time (fall)	Tf		-	150	250	ms

Controller Information

Built-in SPLC501C. Download specification at http://www.newhavendisplay.com/app_notes/SPLC501C.pdf

Timing Characteristics

8.6.2. System bus read/write characteristics 2 (6800 series MPU)

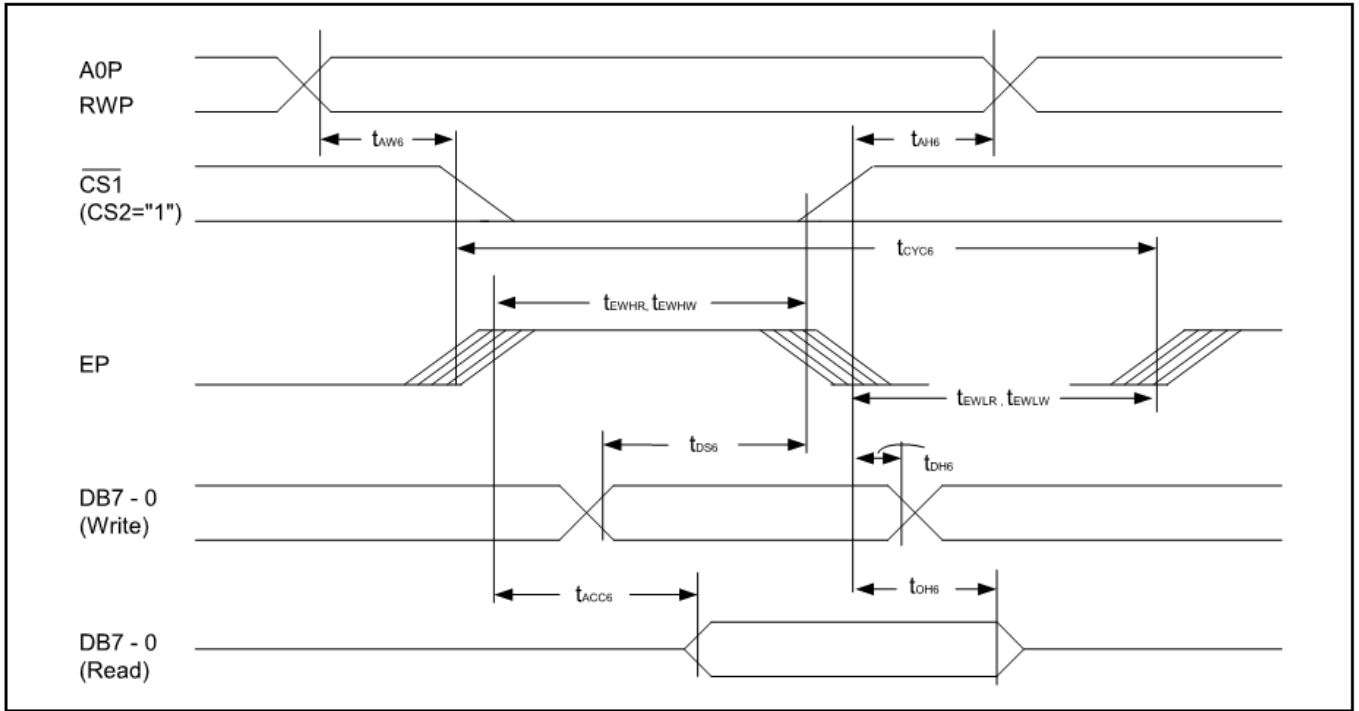

Item	Signal	Symbol	Condition	Rating		Units
				Min.	Max.	
Address hold time	A0P	t_{AH6}		0	-	ns
Address setup time	A0P	t_{AW6}		0	-	ns
System cycle time	A0P	t_{CYC6}		166	-	ns
Data setup time	DB7 - 0	t_{DS6}	$C_L = 100pF$	30	-	ns
Data hold time		t_{DH6}		10	-	ns
Access time	DB7 - 0	t_{ACC6}		-	70	ns
Output disable time		t_{OH6}		10	50	ns
Enable H pulse time	Read	EP	t_{EWHR}	70	-	ns
	Write		t_{EWHW}	30	-	ns
Enable L pulse time	Read	EP	t_{EWLR}	30	-	ns
	Write		t_{EWLW}	30	-	ns

The serial interface

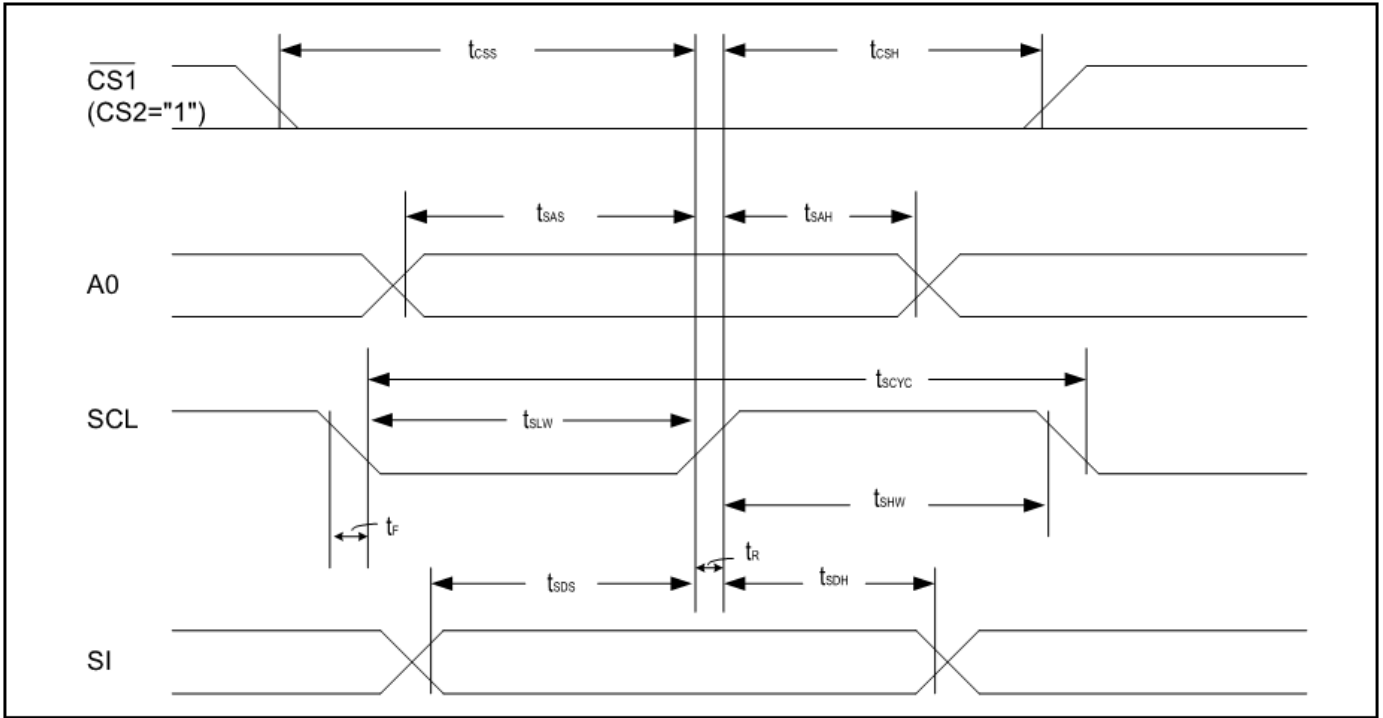

Item	Signal	Symbol	Condition	Rating		Units
				Min.	Max.	
Serial Clock Period		tSCYC	-	250	-	ns
SCL 'H' pulse width	SCL	tSHW	-	100	-	ns
SCL 'L' pulse width		tSLW	-	100	-	ns
Address setup time	A0P	tSAS	-	150	-	ns
Address hold time		tSAH	-	150	-	ns
Data setup time	SI	tSDS	-	100	-	ns
Data hold time		tSDH	-	100	-	ns
CS-SCL time	CS	tCSS	-	150	-	ns
		tCSH	-	150	-	ns

Table of Commands

Command	Command Code											Function
	A0P	RD	WR	DB7	DB6	DB5	DB4	DB3	DB2	DB1	DB0	
1). Display ON/OFF	0	1	0	1	0	1	0	1	1	1	0	LCD display ON/OFF 0: OFF, 1: ON
2). Display start line set	0	1	0	0	1	Display start address					1	Sets the display RAM display start line address
3). Page address set	0	1	0	1	0	1	1	Page address				Sets the display RAM page address
4). Column address set upper bit	0	1	0	0	0	0	1	Most significant column address				Sets the most significant 4 bits of the display RAM column address.
Column address set lower bit	0	1	0	0	0	0	0	Least significant column address				Set the least significant 4 bits of the display RAM column address.
5). Status read	0	0	1	Status				0	0	0	0	Reads the status data
6). Display data write	1	1	0	Write data							0	Writes to the display RAM
7). Display data read	1	0	1	Read data							0	Reads from the display RAM
8). ADC select	0	1	0	1	0	1	0	0	0	0	0	Sets the display RAM address SEG output correspondence 0: normal, 1:reverse
9). Display normal/reverse	0	1	0	1	0	1	0	0	1	1	0	Sets the LCD display normal/ reverse 0: normal, 1:reverse
10). Display all points ON/OFF	0	1	0	1	0	1	0	0	1	0	0	Display all points 0: normal display 1: all points ON
11). LCD bias set	0	1	0	1	0	1	0	0	0	1	0	Sets the LCD driver voltage bias ratio SPLC501C.....0:1/9, 1:1/7
12). Read/modify/write	0	1	0	1	1	1	0	0	0	0	0	Column address increment At write: +1 At read: 0
13). End	0	1	0	1	1	1	0	1	1	1	0	Clear read/modify/write
14). Reset	0	1	0	1	1	1	0	0	0	1	0	Internal reset
15). Common output mode select	0	1	0	1	1	0	0	0	*	*	*	Select COM output scan direction 0: normal direction, 1: reverse direction
16). Power control set	0	1	0	0	0	1	0	1	Operating mode			Select internal power supply operating mode
17). V _s voltage regulator internal resistor ratio set	0	1	0	0	0	1	0	0	Resistor ratio			Select internal resistor ratio (Rb/Ra) mode
18). Electronic volume mode set	0	1	0	1	0	0	0	0	0	0	1	Set the V _s output voltage electronic volume register
Electronic volume register set	0	1	0	*	*	Electronic volume value						

Command	Command Code										Function	
	A0P	RD	WR	DB7	DB6	DB5	DB4	DB3	DB2	DB1		DB0
19). Static indicator ON/OFF Static indicator Register set				1	0	1	0	1	1	0	0	0: OFF, 1: ON 1 Set the flashing mode
20). Page Blink Page selection	0	1	0	1	1	0	1	0	1	0	1	P7 - 0: 1 - blinking page 0 - no blinking, normal display
21). Driving Mode Set Mode selection	0	1	0	1	1	0	1	0	0	1	0	Set the driving mode register Driving capability (D1, D0): (1,1)>(0,0)>(0,1)>(1,0)
22). Power saver												Display OFF and display all points ON compound command
23). NOP	0	1	0	1	1	1	0	0	0	1	1	Command for non-operation
24). Test	0	1	0	1	1	1	1	*	*	*	*	Command for IC test. Do not use this command

Example Initialization Program

```

-----
Sub Init
Reset P3.7           'set Read/write to '0' for write
Reset P3.0           'RS
Set P3.1             'reset
Reset P3.4 'E
'Set P3.3
'Reset P3.3
Waitms 2
'Set P3.3
Waitms 20
A = &HA2             '1/9 BIAS
Call Writecom
A = &HA0             'ADC SELECT , NORMAL
Call Writecom
A = &HC8             'COM OUTPUT REVERSE
Call Writecom
A = &HA4             'DISPLAY ALL POINTS NORMAL
Call Writecom
A = &H40             'DISPLAY START LINE SET
Call Writecom
A = &H25             'INTERNAL RESISTOR RATIO
Call Writecom
A = &H81             'ELECTRONIC VOLUME MODE SET
Call Writecom
A = &H10             'ELECTRONIC VOLUME
Call Writecom
A = &H2F             'POWER CONTROLLER SET
Call Writecom
A = &HAF             'DISPLAY ON
Call Writecom
End Sub

```

```

-----
Sub Writecom
Reset P3.0           'A0 low
Reset P3.7           'R/W low
Set P3.6             'CS2
Set P3.4             'E
P1 = A
Reset P3.4
Reset P3.6
Reset P3.7
End Sub

```

```

Sub Writedata
Set P3.0             'A0 high
Reset P3.7           'R/W low
Set P3.6             'CS2
Set P3.4             'E
P1 = A
Reset P3.4
Reset P3.6
Reset P3.7
End Sub

```

Quality Information

Test Item	Content of Test	Test Condition	Note
High Temperature storage	Endurance test applying the high storage temperature for a long time.	+80°C , 48hrs	2
Low Temperature storage	Endurance test applying the low storage temperature for a long time.	-30°C , 48hrs	1,2
High Temperature Operation	Endurance test applying the electric stress (voltage & current) and the high thermal stress for a long time.	+70°C 48hrs	2
Low Temperature Operation	Endurance test applying the electric stress (voltage & current) and the low thermal stress for a long time.	-20°C , 48hrs	1,2
High Temperature / Humidity Operation	Endurance test applying the electric stress (voltage & current) and the high thermal with high humidity stress for a long time.	+40°C , 90% RH , 48hrs	1,2
Thermal Shock resistance	Endurance test applying the electric stress (voltage & current) during a cycle of low and high thermal stress.	-0°C,30min -> 25°C,5min -> 50°C,30min = 1 cycle 10 cycles	
Vibration test	Endurance test applying vibration to simulate transportation and use.	10-55Hz , 15mm amplitude. 60 sec in each of 3 directions X,Y,Z For 15 minutes	3
Static electricity test	Endurance test applying electric static discharge.	VS=800V, RS=1.5kΩ, CS=100pF One time	

Note 1: No condensation to be observed.

Note 2: Conducted after 4 hours of storage at 25°C, 0%RH.

Note 3: Test performed on product itself, not inside a container.

Precautions for using LCDs/LCMs

See Precautions at www.newhavendisplay.com/specs/precautions.pdf

Warranty Information and Terms & Conditions

http://www.newhavendisplay.com/index.php?main_page=terms