

## Excellent Integrated System Limited

Stocking Distributor

Click to view price, real time Inventory, Delivery & Lifecycle Information:

[E-Switch](#)  
[TL3340AF160QG](#)

For any questions, you can email us directly:

[sales@integrated-circuit.com](mailto:sales@integrated-circuit.com)

SHEET 1 OF 1

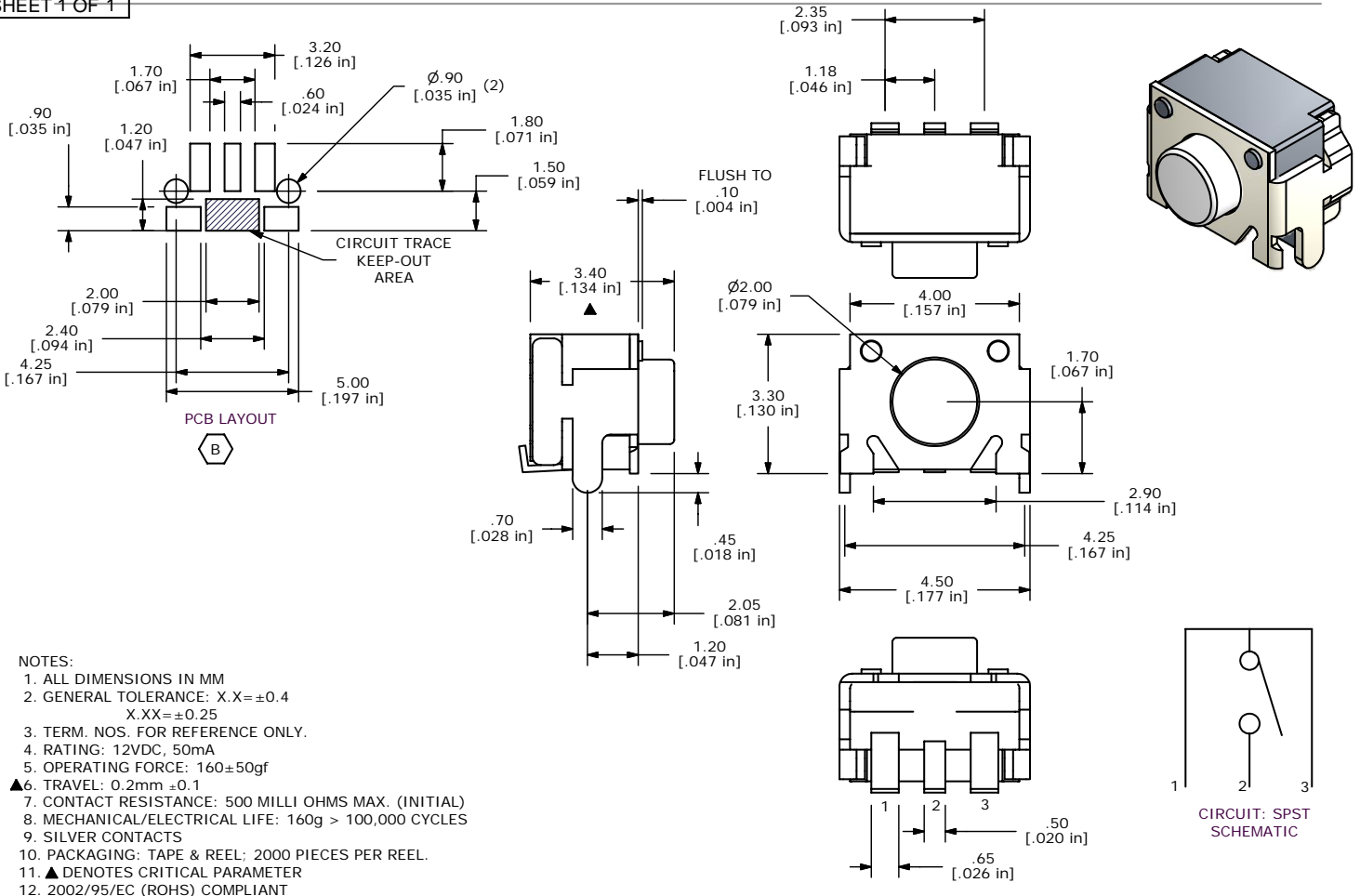

TITLE TL3340AF160QG			
SCALE 8:1	DATE 1/7/2008	DR RC	DWG P021301
			REV B

B	17914	OVERRIDE (5x) DIMS IN PCB LAYOUT	1/7/08	BLR
A	17599	RELEASED FOR PRODUCTION	8/28/07	RC
REV	PCR NO	DESCRIPTION	DATE	BY

THE INFORMATION CONTAINED IN THIS DOCUMENT IS PROPRIETARY TO E-SWITCH AND IS NOT TO BE COPIED OR TRANSFERRED