



Distributor of TE Connectivity AMP Connectors: Excellent Integrated System Limited
Datasheet of 1734186-1 - D-Sub Connector Receptacle, Female Sockets 15 Position Through
Hole Solder

Contact us: sales@integrated-circuit.com Website: www.integrated-circuit.com

Excellent Integrated System Limited

Stocking Distributor

Click to view price, real time Inventory, Delivery & Lifecycle Information:

[TE Connectivity AMP Connectors](#)
[1734186-1](#)

For any questions, you can email us directly:

sales@integrated-circuit.com

4

3

2

1

THIS DRAWING IS UNPUBLISHED. RELEASED FOR PUBLICATION
 © COPYRIGHT BY TYCO ELECTRONICS CORPORATION. ALL RIGHTS RESERVED.

LOC DW DIST

P	LTR	DESCRIPTION	DATE	DWN	APVD
C		REVISED (ECR-09-020253)	11SEP09	JL	WK

REVISIONS

NOTE:

- MATERIAL:
 - HOUSING: THERMOPLASTIC, NY9T WITH 30% GF, UL 94V-0, COLOR: SEE TABLE.
 - CONTACTS: PHOSPHOR BRONZE
 - SHELL: STEEL
 - BOARDLOCKS: BRASS
 - RIVET: BRASS
- FINISH:
 - CONTACTS:
 - GOLD PLATING ON CONTACT AREA. (SEE TABLE)
 - 2.54um[100u"] MIN. MATTE TIN PLATING ON SOLDER TAIL AREA
 - 1.27um[50u"] MIN. NICKEL UNDERPLATED OVERALL
 - BOARDLOCK:
 - 2.54um[100u"] MIN MATTE TIN PLATING,
 - 1.27um[50u"] MIN NICKEL UNDERPLATED OVERALL
 - SHELL: 1.27um[50u"] MIN. NICKEL PLATED
 - RIVET: 1.27um[50u"] MIN. NICKEL PLATED
- RECOMMENDED PCB THICKNESS: 1.6mm
- REFLOW SOLDER CAPABLE TO 260°C PER TE TEST SPEC. 109-201, CONDITION B.

△ CONTACT #9 RECESSED 1.27mm FROM OTHER CONTACTS ON MATING FACE PLANE.
 △ SCREWLOCK IS OPTIONAL (PN 1734186-3 & 6-1734186-1 ARE EQUIPPED WITH 2 SCREWLOCKS)
 7. THREADED INSERTS AND SCREWLOCKS MUST WITHSTAND TIGHTEN TORQUE: 7 Kg-cm MAX.
 8. THREADED INSERTS AND SCREWLOCKS MUST WITHSTAND LOOSEN TORQUE: 1 Kg-cm MIN.

OPTIONAL SCREWLOCK #4-40 UNC 2 PLC

RECOMMENDED PCB LAYOUT PCB TOLERANCE ±0.05

DETAIL A SCALE 4/1

OPTIONAL SCREWLOCK

OBsolete	W/O	W/	661C BLUE	2.5	G/F	6-1734186-1
			BLACK	2.5	0.381um(15u")	5-1734186-2
			661C BLUE	2.5	0.381um(15u")	5-1734186-1
			BLACK	2.5	G/F	4-1734186-1
			661C BLUE	2.5	G/F	4-1734186-2
			BLACK	2.0	0.381um(15u")	1-1734186-2
			661C BLUE	2.0	0.381um(15u")	1-1734186-3
			661C BLUE	2.0	G/F	1734186-3
			BLACK	2.0	G/F	1734186-2
			661C BLUE	2.0	G/F	1734186-1

△ SCREWLOCK HOUSING COLOR DIM. B GOLD PLATING PART NO.

THIS DRAWING IS A CONTROLLED DOCUMENT.

DWN J. LAI 11SEP2009	11SEP2009	Tyco Electronics Corporation Taipi, Taiwan	
CHK S. CHIFEN 11SEP2009	11SEP2009	NAME RECEPTACLE ASSEMBLY, SLIM LINE, 15 POS, VESA	
APVD W. KODAMA 11SEP2009	11SEP2009	PRODUCT SPEC 108-57649	
QUALIFICATION TEST REPORT 501-57755		SIZE A3	CAGE CODE 00779
MATERIAL SEE NOTE		WEIGHT 5.38 GRAMS	DRAWING NO C=1734186
DIMENSIONS: MM TOLERANCES UNLESS OTHERWISE SPECIFIED: 0 PLC ± - 1 PLC ± 0.38 2 PLC ± 0.25 3 PLC ± 0.15 4 PLC ± - ANGLES ± -		CUSTOMER DRAWING	
FINISH SEE NOTE		SCALE	SHEET 1 of 2

AMP 1470-19 REV 31MAR2000

DWC NO 1734186

THIS DRAWING IS A CONTROLLED DOCUMENT.

USED ON _____

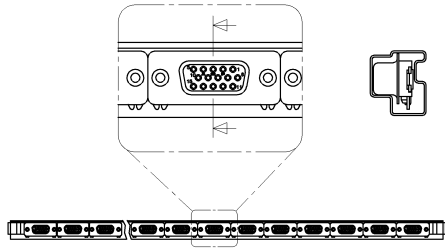
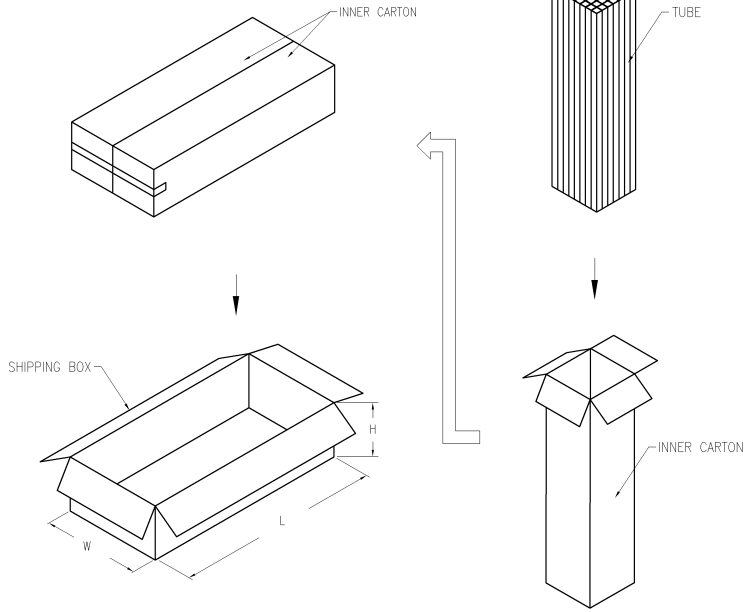

- NOTE:
- PACKAGING MATERIAL IN PLASTIC, RUBBER, INK, PIGMENT AND PAINT MUST MEET CONTROLLED SUBSTANCES SPEC PER 230-702 (REV.E).
 * CADMIUM AND CADMIUM COMPOUNDS NOT TO EXCEED: 5 PPM.
 * LEAD, CADMIUM, CHROM VI AND MERCURY NOT TO EXCEED: 100 PPM (COMBINED).
 - DIMENSION:
 - 2.1 TUBE: L=585, W=17.6, H=15.2
 - 2.2 SHIPPING CARTON: L=620, W=300, H=180
 - QUANTITY:
 - 3.1 PRIMARY PACKING: 18 PCS/TUBE
 - 3.2 SECONDARY PACKING: 50 TUBE/INNER CARTON
 - 3.3 THIRD PACKING: 2 INNER BOX/BOX(1800PCS)
 - BOX WEIGHT:
 - 4.1 NET WEIGHT: 9.7 KG
 - 4.2 GROSS WEIGHT: 11.6 KG

THIS INFORMATION IS CONFIDENTIAL AND PROPRIETARY TO TYCO ELECTRONICS CORPORATION AND ITS WORLDWIDE SUBSIDIARIES. IT IS TO BE USED ONLY FOR THE PURPOSES SPECIFIED HEREIN AND IS NOT TO BE DISCLOSED TO ANY OTHER PARTY WITHOUT THE WRITTEN AUTHORIZATION OF TYCO ELECTRONICS CORPORATION, HARRISBURG, PENNSYLVANIA, USA.

LOC	DW
DIST	

P	LTR	SEE SHEET 1.	DATE	DWN	APVD
		REVISION RECORD			

DIMENSIONS:		TOLERANCES UNLESS OTHERWISE SPECIFIED:	
MM		0 PLC	±
		1 PLC	±
		2 PLC	±
		3 PLC	±
		4 PLC	±

DWN	MATERIAL	HEAT TREAT
CHK		
APVD	Tyco Electronics Corporation Taipei, Taiwan	
NAME: RECEPTACLE ASSEMBLY, SLIM LINE, 15 POS, VESA		
SCALE	SIZE: A3	DRAWING NO: 1734186
	SHEET: 2	OF 2
		REV: C

AMP 3306-7 REV 31MAR2000	8	7	6	5	4	3	2	1
--------------------------	---	---	---	---	---	---	---	---