

Excellent Integrated System Limited

Stocking Distributor

Click to view price, real time Inventory, Delivery & Lifecycle Information:

[Fairchild Semiconductor](#)
[CD4028BCN](#)

For any questions, you can email us directly:

sales@integrated-circuit.com



October 1987
Revised March 2002

CD4028BC BCD-to-Decimal Decoder

General Description

The CD4028BC is a BCD-to-decimal or binary-to-octal decoder consisting of 4 inputs, decoding logic gates, and 10 output buffers. A BCD code applied to the 4 inputs, A, B, C, and D, results in a high level at the selected 1-of-10 decimal decoded outputs. Similarly, a 3-bit binary code applied to inputs A, B, and C is decoded in octal at outputs 0–7. A high level signal at the D input inhibits octal decoding and causes outputs 0–7 to go LOW.

All inputs are protected against static discharge damage by diode clamps to V_{DD} and V_{SS} .

Features

- Wide supply voltage range: 3.0V to 15V
- High noise immunity: $0.45 V_{DD}$ (typ.)
- Low power TTL compatibility: fan out of 2 driving 74L or 1 driving 74LS
- Low power
- Glitch free outputs
- "Positive logic" on inputs and outputs

Applications

- Code conversion
- Address decoding
- Indicator-tube decoder

Ordering Code:

Order Number	Package Number	Package Description
CD4028BCM	M16A	16-Lead Small Outline Integrated Circuit (SOIC), JEDEC MS-012, 0.150" Narrow
CD4028BCN	N16E	16-Lead Plastic Dual-In-Line Package (PDIP), JEDEC MS-001, 0.300" Wide

Devices also available in Tape and Reel. Specify by appending the suffix letter "X" to the ordering code.

Connection Diagram

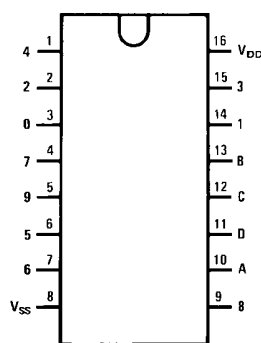

Top View

CD4028BC

Truth Table

	D	C	B	A	0	1	2	3	4	5	6	7	8	9	
1 = HIGH Level 0 = LOW Level	0	0	0	0	1	0	0	0	0	0	0	0	0	0	BCD States
	0	0	0	1	0	1	0	0	0	0	0	0	0	0	
	0	0	1	0	0	0	1	0	0	0	0	0	0	0	
	0	0	1	1	0	0	0	1	0	0	0	0	0	0	
	0	1	0	0	0	0	0	0	1	0	0	0	0	0	
	0	1	0	1	0	0	0	0	0	1	0	0	0	0	
	0	1	1	0	0	0	0	0	0	0	1	0	0	0	
	0	1	1	1	0	0	0	0	0	0	0	1	0	0	
	1	0	0	0	0	0	0	0	0	0	0	0	1	0	
	1	0	0	1	0	0	0	0	0	0	0	0	0	1	
	1	0	1	0	0	0	0	0	0	0	0	1	0	Extraordinary States	
	1	0	1	1	0	0	0	0	0	0	0	0	1		
	1	1	0	0	0	0	0	0	0	0	0	1	0		
	1	1	0	1	0	0	0	0	0	0	0	0	1		
	1	1	1	0	0	0	0	0	0	0	0	0	1		
	1	1	1	1	0	0	0	0	0	0	0	0	1		

Logic Diagram

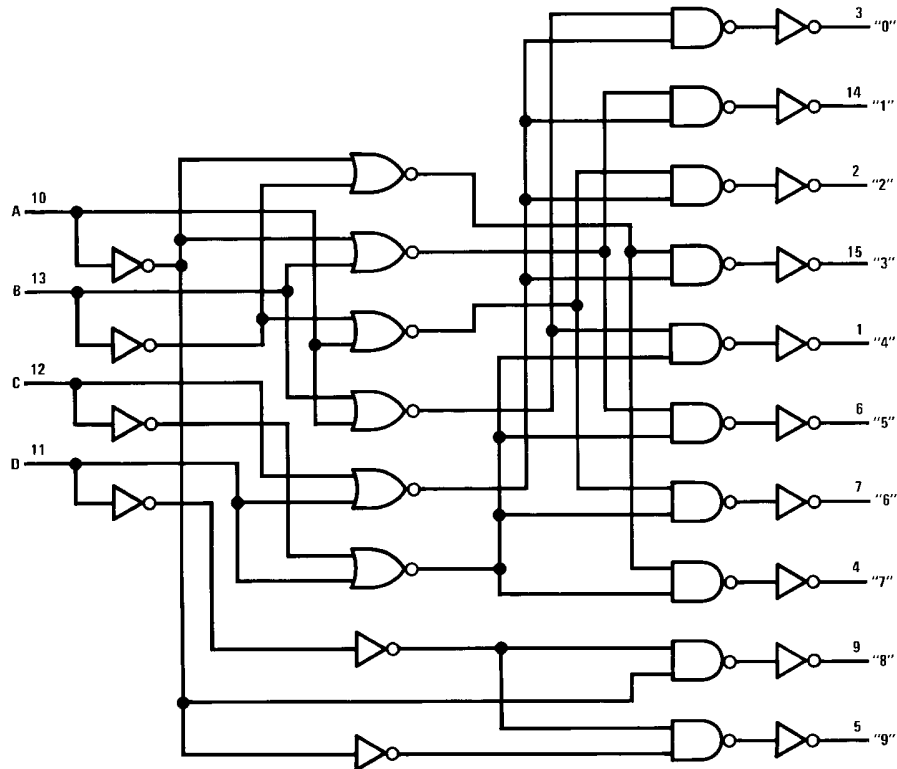

Absolute Maximum Ratings (Note 1)			Recommended Operating Conditions (Note 2)							
(Note 2)										
Supply Voltage (V_{DD})		-0.5 to +18V	Supply Voltage (V_{DD})			3 to 15V				
Input Voltage (V_{IN})		-0.5 to $V_{DD} + 0.5V$	Input Voltage (V_{IN})			0 to $V_{DD}V$				
Storage Temperature Range (T_S)		-65°C to +150°C	Operating Temperature Range (T_A)			-55°C to +125°C				
Power Dissipation (P_D)			Note 1: "Absolute Maximum Ratings" are those values beyond which the safety of the device cannot be guaranteed, they are not meant to imply that the devices should be operated at these limits. The table of "Recommended Operating Conditions" and "Electrical Characteristics" provides conditions for actual device operation.							
Dual-In-Line		700 mW	Note 2: $V_{SS} = 0V$ unless otherwise specified.							
Small Outline		500 mW								
Lead Temperature (T_L)										
(Soldering, 10 seconds)		260°C								
DC Electrical Characteristics (Note 2)										
Symbol	Parameter	Conditions	-55°C		+25°C		+125°C		Units	
			Min	Max	Min	Typ	Max	Min		Max
I_{DD}	Quiescent Device Current	$V_{DD} = 5V, V_{IN} = V_{DD}$ or V_{SS}		5		0.01	5		150	μA
		$V_{DD} = 10V, V_{IN} = V_{DD}$ or V_{SS}		10		0.01	10		300	
		$V_{DD} = 15V, V_{IN} = V_{DD}$ or V_{SS}		20		0.02	20		600	
V_{OL}	LOW Level Output Voltage	$ I_{O} < 1 \mu A, V_{IL} = 0V, V_{IH} = V_{DD}$								V
		$V_{DD} = 5V$		0.05		0	0.05		0.05	
		$V_{DD} = 10V$		0.05		0	0.05		0.05	
		$V_{DD} = 15V$		0.05		0	0.05		0.05	
V_{OH}	HIGH Level Output Voltage	$ I_{O} < 1 \mu A, V_{IL} = 0V, V_{IH} = V_{DD}$								V
		$V_{DD} = 5V$	4.95		4.95	5		4.95		
		$V_{DD} = 10V$	9.95		9.95	10		9.95		
		$V_{DD} = 15V$	14.95		14.95	15		14.95		
V_{IL}	LOW Level Input Voltage	$ I_{O} < 1 \mu A$								V
		$V_{DD} = 5V, V_O = 0.5V$ or $4.5V$		1.5		2.25	1.5		1.5	
		$V_{DD} = 10V, V_O = 1V$ or $9V$		3.0		4.5	3.0		3.0	
		$V_{DD} = 15V, V_O = 1.5V$ or $13.5V$		4.0		6.75	4.0		4.0	
V_{IH}	HIGH Level Input Voltage	$ I_{O} < 1 \mu A$								V
		$V_{DD} = 5V, V_O = 0.5V$ or $4.5V$	3.5		3.5	2.75		3.5		
		$V_{DD} = 10V, V_O = 1V$ or $9V$	7.0		7.0	5.5		7.0		
		$V_{DD} = 15V, V_O = 1.5V$ or $13.5V$	11.0		11.0	8.25		11.0		
I_{OL}	LOW Level Output Current (Note 3)	$V_{IH} = V_{DD}, V_{IL} = 0V$								mA
		$V_{DD} = 5V, V_O = 0.4V$	0.64		0.51	1.0		0.36		
		$V_{DD} = 10V, V_O = 0.5V$	1.6		1.3	2.6		0.9		
		$V_{DD} = 15V, V_O = 1.5V$	4.2		3.4	6.8		2.4		
I_{OH}	HIGH Level Output Current (Note 3)	$V_{IH} = V_{DD}, V_{IL} = 0V$								mA
		$V_{DD} = 5V, V_O = 4.6V$	-0.25		-0.2	-0.4		-0.14		
		$V_{DD} = 10V, V_O = 9.5V$	-0.62		-0.5	-1.0		-0.35		
		$V_{DD} = 15V, V_O = 13.5V$	-1.8		-1.5	-3.0		-1.1		
I_{IN}	Input Current	$V_{DD} = 15V, V_{IN} = 0V$		-0.1			-0.1		-1.0	μA
		$V_{DD} = 15V, V_{IN} = 15V$		0.1			0.1		1.0	
Note 3: I_{OL} and I_{OH} are tested one output at a time.										

CD4028BC

AC Electrical Characteristics (Note 4)

$T_A = 25^\circ\text{C}$, $C_L = 50\text{ pF}$, $R_L = 200\text{ k}$, Input $t_r = t_f = 20\text{ ns}$, unless otherwise specified

Symbol	Parameter	Conditions	Min	Typ	Max	Units
t_{PHL} or t_{PLH}	Propagation Delay Time	$V_{CC} = 5\text{V}$ $V_{CC} = 10\text{V}$ $V_{CC} = 15\text{V}$		240 100 70	480 200 140	ns
t_{THL} or t_{TLH}	Transition Time	$V_{CC} = 5\text{V}$ $V_{CC} = 10\text{V}$ $V_{CC} = 15\text{V}$		175 75 60	350 150 110	ns
C_{IN}	Input Capacitance	Any Input		5	7.5	pF

Note 4: AC Parameters are guaranteed by DC correlated testing.

Switching Time Waveforms

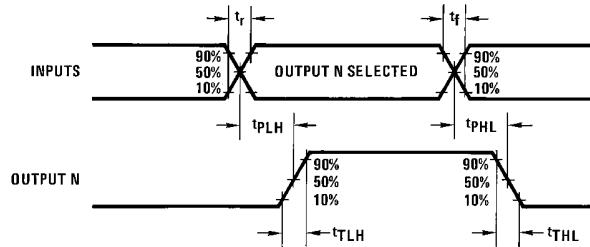

Physical Dimensions inches (millimeters) unless otherwise noted

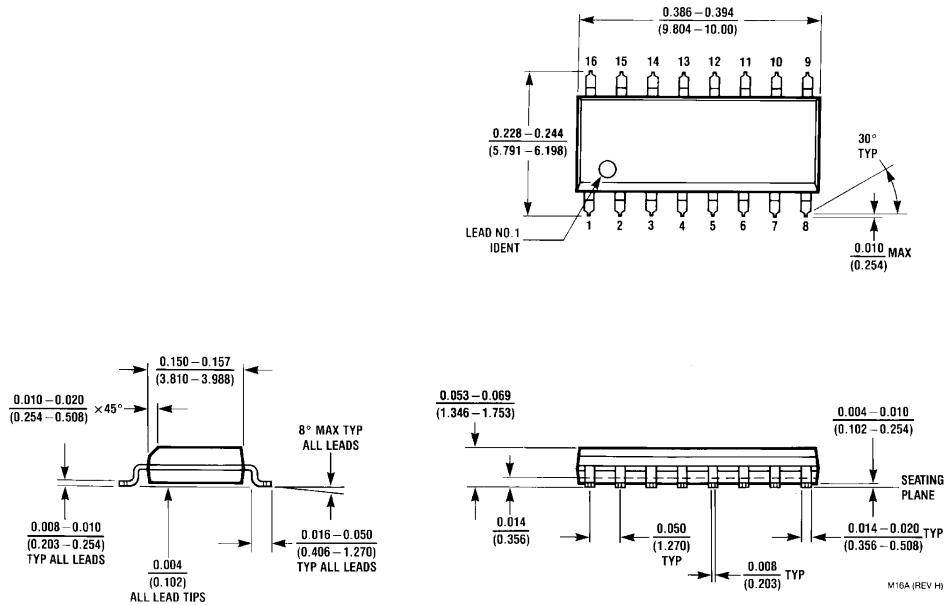

16-Lead Small Outline Integrated Circuit (SOIC), JEDEC MS-012, 0.150" Narrow Package Number M16A

M16A (REV H)

CD4028BC BCD-to-Decimal Decoder

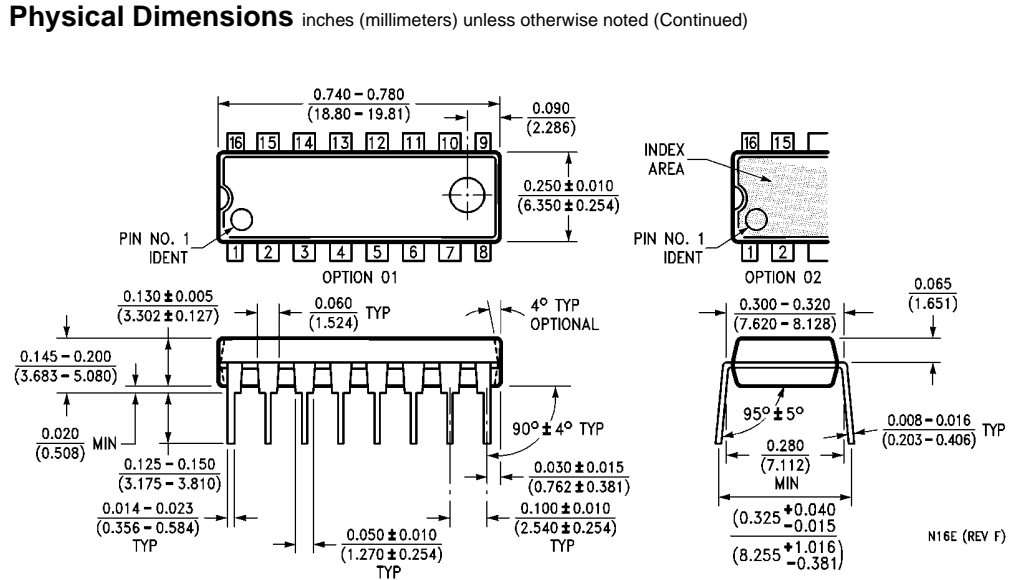

**16-Lead Plastic Dual-In-Line Package (PDIP), JEDEC MS-001, 0.300" Wide
 Package Number N16E**

Fairchild does not assume any responsibility for use of any circuitry described, no circuit patent licenses are implied and Fairchild reserves the right at any time without notice to change said circuitry and specifications.

LIFE SUPPORT POLICY

FAIRCHILD'S PRODUCTS ARE NOT AUTHORIZED FOR USE AS CRITICAL COMPONENTS IN LIFE SUPPORT DEVICES OR SYSTEMS WITHOUT THE EXPRESS WRITTEN APPROVAL OF THE PRESIDENT OF FAIRCHILD SEMICONDUCTOR CORPORATION. As used herein:

1. Life support devices or systems are devices or systems which, (a) are intended for surgical implant into the body, or (b) support or sustain life, and (c) whose failure to perform when properly used in accordance with instructions for use provided in the labeling, can be reasonably expected to result in a significant injury to the user.
2. A critical component in any component of a life support device or system whose failure to perform can be reasonably expected to cause the failure of the life support device or system, or to affect its safety or effectiveness.

www.fairchildsemi.com