

Excellent Integrated System Limited

Stocking Distributor

Click to view price, real time Inventory, Delivery & Lifecycle Information:

[Texas Instruments](#)
[TALP1000B](#)

For any questions, you can email us directly:

sales@integrated-circuit.com

Dual-Axis Analog MEMS Pointing Mirror

Check for Samples: [TALP1000B](#)

FEATURES

- Two Axis, Gimbaled Mirror
- ± 5 Degrees Mechanical Rotation
- One Mirror, 9 mm² in Area
- Electromagnetic Actuation
- Low Voltage Operation
- Low Optical Insertion Loss (>95% Reflectivity, >5 m Radius of Curvature)
- High Precision Position Feedback (13-Bit Resolution)
- High Performance (<5 ms Switch Time)
- High Reliability
- Cost Effective Solution
- Simple Drive Requirements – Tilt Angle Linear with Applied Current
- Windowless Package – Allows Use in Multiple Light Steering Applications

APPLICATIONS

- Optical Networking
 - ROADM (Reconfigurable Optical Add/Drop Multiplexer)
 - Channel Monitors
- Free Space Optical Communication
 - Outdoor Links
 - Indoor Links (Readily Reconfigurable)
 - At Trade Shows
 - On Production Floors
 - In an Office Area From Cubicle to Hubs
 - In Home Theater From Entertainment Center to Wall-Mounted HDTV
- Optical Alignment
 - Precise Light Steering and Control
- General Laser Steering that Requires a Large (3 mm) Mirror
 - LADAR (Laser Detection and Ranging) Object Detection

DESCRIPTION

The TALP1000B is a high-performance micromirror designed for use in multiple light steering applications. The large 2-axis micromirror is constructed of single crystal silicon, which has no grain boundaries and is virtually defect free. This produces a hinge with no work hardening and gives the TALP1000B superior reliability characteristics. The gold coated optically active surface of the TALP1000B provides excellent reflectivity in the 700 nm – 10 μ m wavelength range. The mirror's large size, large radius of curvature and high reflectivity make it easy to incorporate into many optical designs.

The electromagnetic drive of the TALP1000B allows low voltage and low-power actuation. The mirror can be driven using an analog drive resulting in precise pointing resolution over the entire range of motion. Each rotation axis of the device is individually and independently actuated.

Integrated position feedback on the TALP1000B is optical based and provides greater than 13 bit pointing precision. Additionally, the position feedback can be used in conjunction with a servo loop to achieve <5 millisecond point-to-point switch times.

The ceramic circuit board base provides a mechanically rigid design, and the three point mounting interface allows precise and repeatable assembly into system hardware. The compact size of the TALP1000B is ideal for systems with small footprint requirements.



Please be aware that an important notice concerning availability, standard warranty, and use in critical applications of Texas Instruments semiconductor products and disclaimers thereto appears at the end of this data sheet.

Circuit Schematic

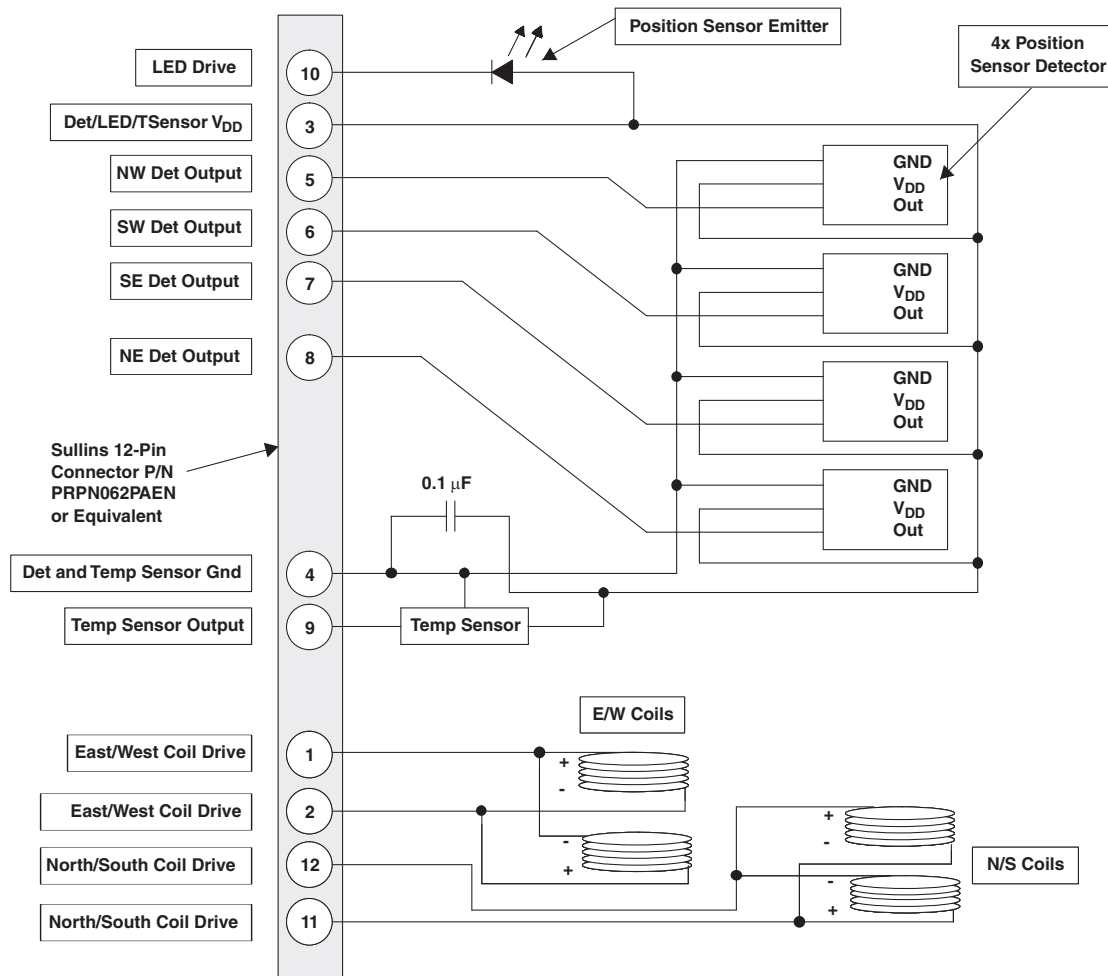

- A. When a positive voltage is applied to pin #1 (a lower voltage is returned from pin #2), a beam reflected off the mirror rotates in the westerly direction. When a positive voltage is applied to pin #12 (a lower voltage is returned from pin #11), a beam reflected off the mirror rotates in the northerly direction. North and west arrows are on both sides of the package.

RECOMMENDED OPERATING CONDITIONS

over operating free-air temperature range (unless otherwise noted)

	MIN	NOM	MAX	UNIT
Operating temperature range	-10		70	°C
Storage temperature, T _{stg}	-50		85	°C

ELECTRO/MECHANICAL CHARACTERISTICS

over operating supply voltage and operating temperature ranges (unless otherwise noted)

PARAMETER	TEST CONDITIONS	MIN	TYP	MAX	UNIT
V _{CC} Supply voltage	Typical power supply rejection of position sensor detectors is >50 dB, 20 kHz to 50 kHz.	4.8		5.2	V
Power dissipation	At maximum angle for both axes, includes position feedback and coil drive. 0.65 to 10 micron wavelength range			700	mW
Mechanical rotation	Applies to both axes, each axis independent, angle relative to plane determined by mirror-side mounting positions, over the entire temperature range.	0		±5	deg
Mirror resonance frequency	Measured at 25°C and 0 degree rotation	112		152	Hz
Gimbals resonance frequency	Measured at 25°C and 0 degree rotation	100		140	Hz
Resonance frequency variation over operating temperature range				10	Hz
Resonance frequency variation over rotation range—each axis				8	Hz
Mirror mechanical Q	Measured by fitting exponential decay after removing 2-mA current pulse. Quiescent angle, 25°C	100			
Coil current at maximum rotation	Over the entire temperature range	20		65	mA
Mirror drift at constant coil current	Mirror position is stable to within 5% of full angular range (0.5°) over time and operating temperature range.			5%	
Coil drive linearity	Difference between a mirror angle at a given current, and the angle predicted by a linear fit to angle versus current over the range of ±5 degrees at 25°C			0.4	deg
Coil resistance: each axis	Measured at 25°C, coils use copper wire with variation over temperature given by $R = R_0[1 + a(T - T_0)]$, where, $a = 3.9 \times 10^{-3}/^\circ\text{C}$	61		71	Ω
Quiescent angle: mirror side	Angle relative to plane determined by mirror-side mounting positions, over the entire temperature range			±0.3	deg
Quiescent angle: coil side	Angle relative to plane determined by coil-side mounting positions, over the entire temperature range			±0.5	deg
Mirror crosstalk	Off-axis rotation induced by on-axis actuation relative to axes determined by mirror mounting positions			5%	
Mirror curvature radius	Over the entire temperature range	5			m
Mirror reflectivity	Over the entire temperature range	95%			
Displacement of optical surface from axis of rotation				65	μm
Mirror surface roughness	Measured over a 0.5 mm square window. $\text{rms} = \left(\frac{y_1^2 + y_2^2 + \dots + y_N^2}{N} \right)^{1/2}$ Where y_x are the height elements along the profile and N is the number of discrete elements.			200	nm
Particulates	3 dig surface quality. The diameter of the maximum sized particle on the mirror must not exceed 30 μm (corresponding to 3 dig surface quality). The sum of the diameters of all particles on the mirror must not exceed twice this size. Two particles must not be closer than 200 μm. Particles less than 5 μm are ignored. ⁽¹⁾				

(1) The diameter of an irregularly shaped particle is the average of its length and width.

TALP1000B

Not Recommended For New Designs



SLBS006A –NOVEMBER 2004–REVISED SEPTEMBER 2009

www.ti.com

ELECTRO/MECHANICAL CHARACTERISTICS (continued)

over operating supply voltage and operating temperature ranges (unless otherwise noted)

PARAMETER	TEST CONDITIONS	MIN	TYP	MAX	UNIT
LED current for 3-V sensor output	At quiescent angle over the entire temperature range.			22	mA
Number of position sensor detectors	Axes of position sensor detectors rotated 45 degrees relative to rotation axes	4		4	
Detector output nonuniformity	(Maximum minus minimum of the four detectors) / (minimum of the four detectors). Measured with quiescent mirror at 25°C.			0.6%	
Position sensor power dissipation	Includes single LED and four detectors and temperature sensor over entire temperature range.			100	mW
Position sensor drift	0°C to 70°C, relative to mirror position at 35°C.			±5%	
Position sensor SNR ⁽²⁾	For each axis, at 25°C. ⁽²⁾	4000:1			
SNR per degree	Signal is the change in position sensor output with a 1 degree tilt in angle, and the noise is the standard deviation of the position sensor output with no coil current. Measure between integer angles (–5 to –4 degrees, –4 to –3 degrees, ..., 4 to 5 degrees)	300:1			
Position sensor detector rise and fall times	10%–90% signal rise and fall, over the entire temperature range			70	µs
Position sensor detector output voltage	At 25°C	0		4.5	V
Output voltage swing for each detector over rotation range	At 25°C	1			V
Differential output voltage swing for two opposing detectors over rotation range	At 25°C	2			V
Position sensor linearity	Difference between the rotation angle at a given sensor output and the angle predicted by a linear fit to angle versus output over the range of ±5 degrees at 25°C			0.5	deg
Position sensor crosstalk	Off-axis sensor output induced by on-axis actuation relative to axes determined by mirror mounting positions, at 25°C			10%	
Mechanical shock	Product has passed 1 ms shock at this level in accordance with Method 2002 and MIL-STD-883			500	g
Temperature cycling	Product has passed testing of 100 cycles across this temperature range in accordance with EIA/TIA-445-3A	–40		85	°C
Vibration	Product has passed vibration testing at 20G across this frequency range in accordance with Method 2007 MIL-STD-883	20		2000	Hz

(2) The position sensor SNR is specified for each axis to be the peak-to-peak sensor output divided by the standard deviation of the sensor output where: position sensor output east west = $PS_{EW} = (NE + SE - NW - SW)/(NE + SE + NW + SW)$, $PS_{NS} = (NE - SE + NW - SW)/(NE + SE + NW + SW)$. NE, SE, NW, and SW denote the voltage outputs of the northeast, southeast, northwest, and southwest detectors respectively. Peak-to-peak output is measured when the mirror is rotated through the full range of motion. Standard deviations are measured at the quiescent angle and all values are sampled simultaneously at 8 kHz for 1 second.

DEVICE INFORMATION

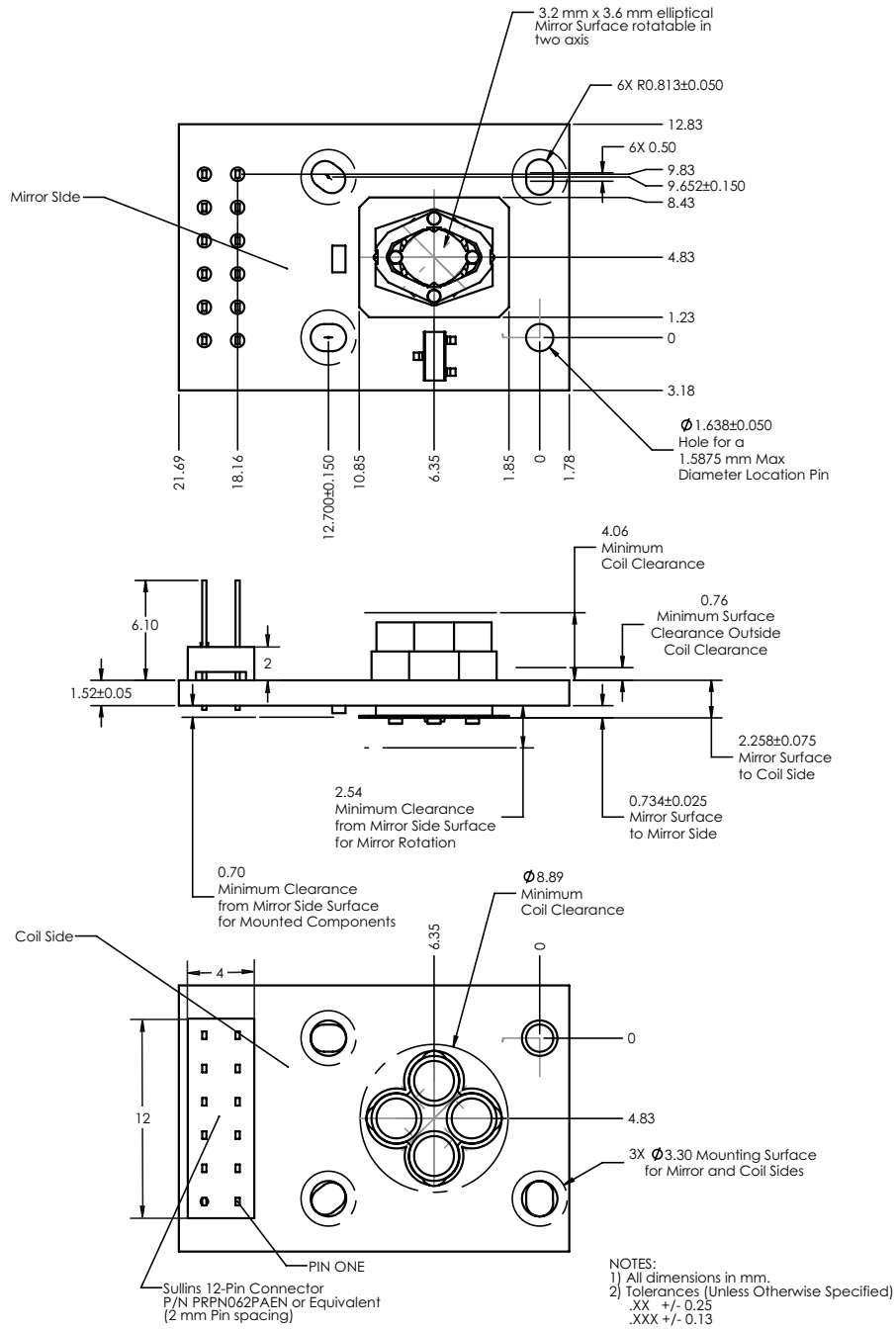

IMPORTANT NOTICE

Texas Instruments Incorporated and its subsidiaries (TI) reserve the right to make corrections, modifications, enhancements, improvements, and other changes to its products and services at any time and to discontinue any product or service without notice. Customers should obtain the latest relevant information before placing orders and should verify that such information is current and complete. All products are sold subject to TI's terms and conditions of sale supplied at the time of order acknowledgment.

TI warrants performance of its hardware products to the specifications applicable at the time of sale in accordance with TI's standard warranty. Testing and other quality control techniques are used to the extent TI deems necessary to support this warranty. Except where mandated by government requirements, testing of all parameters of each product is not necessarily performed.

TI assumes no liability for applications assistance or customer product design. Customers are responsible for their products and applications using TI components. To minimize the risks associated with customer products and applications, customers should provide adequate design and operating safeguards.

TI does not warrant or represent that any license, either express or implied, is granted under any TI patent right, copyright, mask work right, or other TI intellectual property right relating to any combination, machine, or process in which TI products or services are used. Information published by TI regarding third-party products or services does not constitute a license from TI to use such products or services or a warranty or endorsement thereof. Use of such information may require a license from a third party under the patents or other intellectual property of the third party, or a license from TI under the patents or other intellectual property of TI.

Reproduction of TI information in TI data books or data sheets is permissible only if reproduction is without alteration and is accompanied by all associated warranties, conditions, limitations, and notices. Reproduction of this information with alteration is an unfair and deceptive business practice. TI is not responsible or liable for such altered documentation. Information of third parties may be subject to additional restrictions.

Resale of TI products or services with statements different from or beyond the parameters stated by TI for that product or service voids all express and any implied warranties for the associated TI product or service and is an unfair and deceptive business practice. TI is not responsible or liable for any such statements.

TI products are not authorized for use in safety-critical applications (such as life support) where a failure of the TI product would reasonably be expected to cause severe personal injury or death, unless officers of the parties have executed an agreement specifically governing such use. Buyers represent that they have all necessary expertise in the safety and regulatory ramifications of their applications, and acknowledge and agree that they are solely responsible for all legal, regulatory and safety-related requirements concerning their products and any use of TI products in such safety-critical applications, notwithstanding any applications-related information or support that may be provided by TI. Further, Buyers must fully indemnify TI and its representatives against any damages arising out of the use of TI products in such safety-critical applications.

TI products are neither designed nor intended for use in military/aerospace applications or environments unless the TI products are specifically designated by TI as military-grade or "enhanced plastic." Only products designated by TI as military-grade meet military specifications. Buyers acknowledge and agree that any such use of TI products which TI has not designated as military-grade is solely at the Buyer's risk, and that they are solely responsible for compliance with all legal and regulatory requirements in connection with such use.

TI products are neither designed nor intended for use in automotive applications or environments unless the specific TI products are designated by TI as compliant with ISO/TS 16949 requirements. Buyers acknowledge and agree that, if they use any non-designated products in automotive applications, TI will not be responsible for any failure to meet such requirements.

Following are URLs where you can obtain information on other Texas Instruments products and application solutions:

Products

Audio	www.ti.com/audio
Amplifiers	amplifier.ti.com
Data Converters	dataconverter.ti.com
DLP® Products	www.dlp.com
DSP	dsp.ti.com
Clocks and Timers	www.ti.com/clocks
Interface	interface.ti.com
Logic	logic.ti.com
Power Mgmt	power.ti.com
Microcontrollers	microcontroller.ti.com
RFID	www.ti-rfid.com
RF/IF and ZigBee® Solutions	www.ti.com/lprf

Applications

Communications and Telecom	www.ti.com/communications
Computers and Peripherals	www.ti.com/computers
Consumer Electronics	www.ti.com/consumer-apps
Energy and Lighting	www.ti.com/energy
Industrial	www.ti.com/industrial
Medical	www.ti.com/medical
Security	www.ti.com/security
Space, Avionics and Defense	www.ti.com/space-avionics-defense
Transportation and Automotive	www.ti.com/automotive
Video and Imaging	www.ti.com/video
Wireless	www.ti.com/wireless-apps

TI E2E Community Home Page

e2e.ti.com