

Excellent Integrated System Limited

Stocking Distributor

Click to view price, real time Inventory, Delivery & Lifecycle Information:

[Murata Electronics North America](#)
[DM2200-916VM-1](#)

For any questions, you can email us directly:

sales@integrated-circuit.com

DEVELOPMENT KIT
 (Info [Click here](#))



DM2200-916VM-1

916.50 MHz Transceiver Module

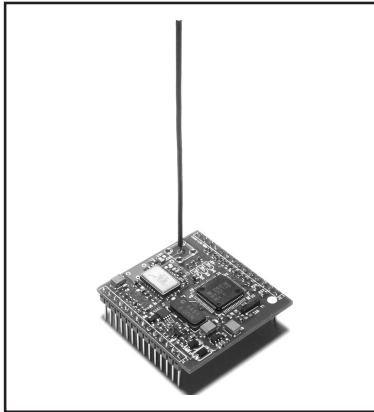

- **RFM VersaMESH™ Versatile Mesh Network Protocol**
- **Up to 600 meters Module to Module range**
- **3 V, Very Low Current Operation plus Sleep Mode**
- **Analog, Digital and Serial I/O Ports**
- **FCC 15.247 Certified**

The DM2200-916VM-1 is a 916.5 MHz transceiver module designed for wireless sensor network applications. The module is equipped with seven general-purpose I/O ports that can be configured as analog-to-digital converter inputs, digital inputs or digital outputs, plus three auxiliary digital I/O ports. The communication range of the DM2200-916VM-1 in an “open field” environment is typically 600 meters/hop. The DM2200-916VM-1 combines RFM’s low-current ASH radio technology with low-power microprocessor technology to achieve very long battery life. The DM2200-916VM-1 employs RFM’s VersaMESH™ protocol, which provides robust wireless mesh network routing, an integrated multitasking operating system, and an extensive set of application support commands. The DM2200-916VM-1 is manufactured with RoHS compliant materials and assembly methods.

Absolute Maximum Ratings

Rating	Value	Units
All I/O Pins Except VIN	-0.3 to +4.0	V
Non-Operating Ambient Temperature Range	-40 to +85	°C

Electrical Characteristics

Characteristic	Sym	Notes	Minimum	Typical	Maximum	Units
Channel Center Frequency	f ₀			916.5		MHz
Modulation Type			OOK on BPSK Spreading Code			
RF Encoded Data Transmission Rate				9.6		kb/s
Receive Mode:						
Average Input Current, 5 Vdc VIN Supply	I _R			5.5	6.0	mA
Pulse Input Signal for 10 ⁻³ BER, 25 °C				-100		dBm
Transmit Mode:						
Peak Input Current, 5 Vdc VIN Supply	I _{TP}			36	38	mA
Peak Transmitter Output Power	P _O			10		dBm
Average Sleep Mode Input Current, 5 Vdc VIN Supply	I _S			65	70	µA
Analog Input Measurement Range (12-bit ADC)			0		V _{DD}	V
External Source Impedance to Analog Input					10	K
Digital Output Source Current, 1K Load				1		mA
Digital Output Sink Current, 1K Load				1.2		mA
Serial Port Default Data Rate				19.2		kb/s
Internal Power Supply Input Voltage Range			3.3		14.0	Vdc
External Power Supply Voltage Range	V _{DD}		2.9		3.7	Vdc
External Power Supply Voltage Ripple					10	mV _{P-P}
Operating Ambient Temperature Range	T _A		-40		+85	°C

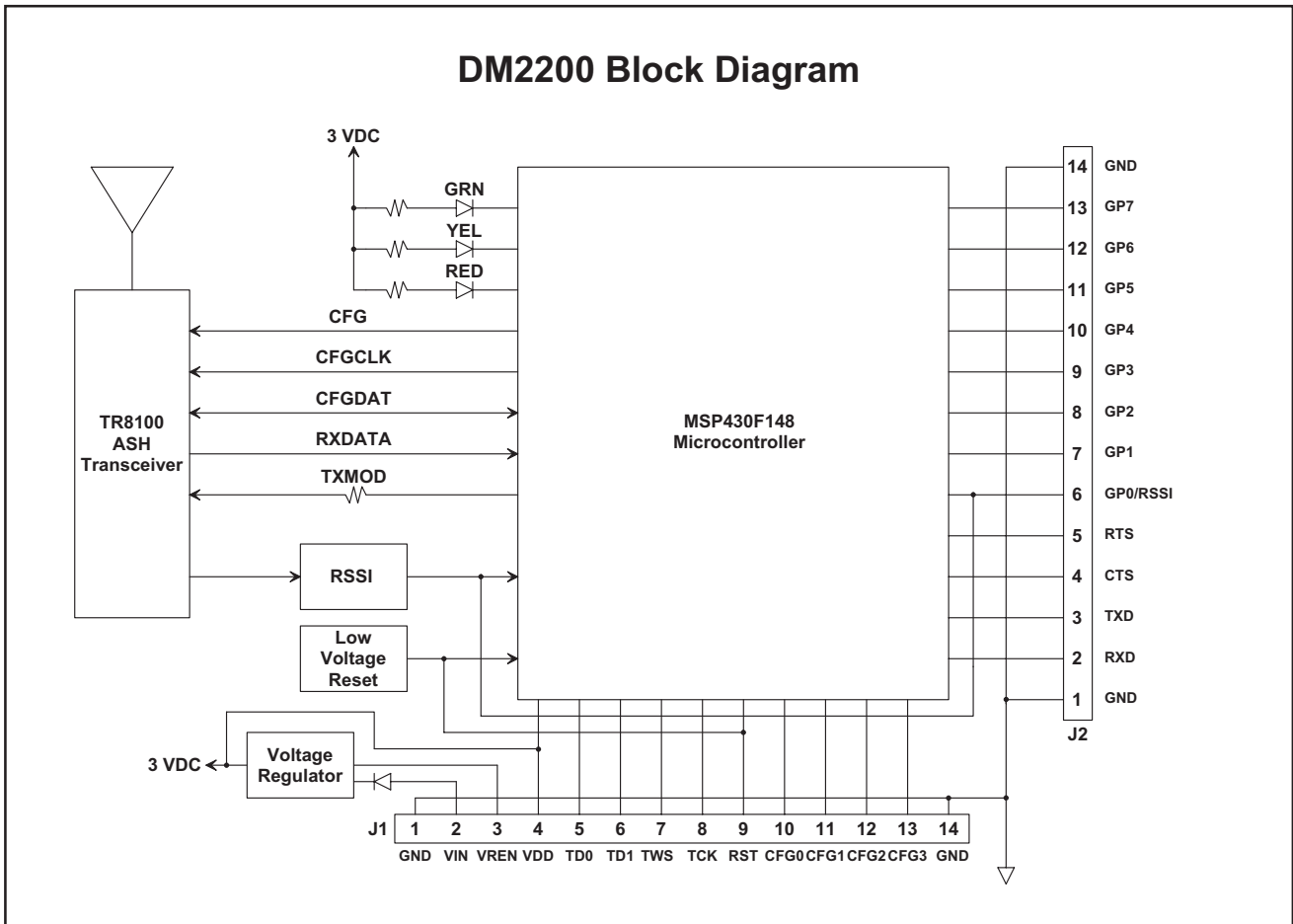

Figure 1

DM2200-916VM-1 Theory of Operation

Major components of the DM2200-916VM-1 wireless sensor network module include the TR8100 ASH transceiver and the TI MSP430F148 microcontroller. The TR8100 operates on 916.5 MHz, with a nominal output power of 10 mW. The MSP430F148 can operate referenced to either a 32.768 kHz or 6 MHz crystal.

The MSP430F148 UART provides a serial interface on connector J2. The microcontroller's eight general-purpose I/O pins, GP0 - GP7 are available on connector J2, along with four auxiliary digital I/O pins, CFG0 - CFG3 on J1. General-purpose I/O pin GP0 is dedicated to measuring the value of the received

signal strength indicator (RSSI) circuit and should always be set as an analog input. Auxiliary digital I/O pin CFG3 is always configured as a digital input to provide a firmware reset function (logic high for normal operation). GP1 through GP7 and CFG0 through CFG2 can be configured as required by the application. The three LEDs on the transceiver module display RF communication activity.

DM2200-916VM-1 operation is based on RFM's VersaMESH™ mesh network protocol, which supports data and command transfers through both the serial interface and the RF channel. See the *DM2200 System User's Guide* and the *DM2200 Software User's Guide* for further details.

DM2200-916VM-1 FCC Certification

The DM2200-916VM-1 is certified for operation under FCC Part 15 Rules, Section 15.247. When the DM2200-916VM-1 is run from an off-board power supply (applied to J1-4), the supply voltage must be limited to a maximum of 3.7 Vdc, and the power supply voltage ripple must not exceed 10 mV_{P-P}.

FCC Labels and Notices

A clearly visible label is required on the outside of the user's (OEM) enclosure stating that this product contains a DM2200-916VM-1 radio module, FCC ID: TE6-DM2200A.

This device complies with Part 15 of the FCC rules. Operation is subject to the following two conditions: (1) this device may not cause harmful interference, and (2) this device must accept any interference received, including interference that may cause undesired operation.

WARNING: This device operates under Part 15 of the FCC rules. Any modification to this device, not expressly authorized by RFM, may void the user's authority to operate this device.

DM2200-916VM-1 Applications

There are two ways to use the DM2200-916VM-1 in an application. The transceiver module can be used with a companion application interface board, the IM2200. The IM2200 has provisions for powering the transceiver module from a USB cable, an external unregulated DC supply such as a 5 Vdc "wall" transformer, an external regulated 3 Vdc power supply, or an external battery. The IM2200 also provides the choice of UART, RS232, or USB for a host computer serial interface. In addition, the IM2200 includes captured-screw terminal strips for connecting analog inputs, digital logic inputs, digital logic outputs and form C relay outputs. Refer to the IM2200 data sheet for additional details.

The DM2200-916VM-1 can also be integrated into the user's own application board. The DM2200-916VM-1 pin descriptions are given in the Table on pages 4 and 5. The transceiver module pin-out locations are shown in Figure 2, and the PCB layout for the mating connectors is shown in Figure 3.

The operating range of the DM2200-916VM-1 depends critically on the antenna being located properly. When using the standard DM2200-916VM-1 antenna (part number 400-1687-001), care should be taken to keep the antenna at least 0.5 inch away from the sides of its enclosure. The enclosure must be made from a plastic with low RF attenuation, such as fiberglass, PVC or ABS. *Note: other antenna configurations are possible, but each new antenna configuration must be added to the DM2200-916VM-1 FCC module certification before deployment.* Contact RFM for details.

The DM2200-916VM-1 enclosure should be mounted so the antenna is at least 4 feet off the ground, and ideally 6 or more feet off the ground.

The DM2200-916VM-1 has an on-board regulator input on Pin J1-2. To use the on-board regulator, connect J1-3 to J1-2 and apply a voltage to this connection of at least 3.3 Vdc, but not greater than 14 Vdc, including ripple variations. When running from the on-board regulator, up to 5 mA is available on J1-4 to operate external circuitry. Any external circuitry connected to J1-4 must not induce more than 10 mV_{P-P} ripple on the regulated 3 Vdc at this pin.

The DM2200-916VM-1 can also be run from an off-board regulated supply or a battery. In this case, connect J1-3 to ground, leave J1-2 unconnected, and apply the regulated supply or battery input to J1-4. Note the input voltage range for J1-4 must be in the range of 2.9 to 3.7 Vdc, with no more than 10 mV_{P-P} ripple.

Only pins J1-2 and J1-3 are rated to operate from a supply voltage higher than 3.7 Vdc. *Further, care must be taken so that analog or logic inputs applied to the transceiver module stay within the voltage range of 0 to VDD (voltage at J1-4). Applying a voltage outside of the 0 to VDD voltage range to an analog or logic input can damage the module.*

The DM2200-916VM-1 has current limiting protection resistors on most of the I/O pins. These limit the current that a logic output can source or sink. Any DM2200-916VM pin defined as an output should be used only to drive a high impedance load such as a CMOS logic input or a MOSFET transistor.

Pin Descriptions

Pin	Name	Description
J1-1	GND	This pin is connected to ground.
J1-2	VIN	This pin is the input to the DM2200-916VM-1 on-board voltage regulator. The minimum input voltage to this pin is 3.3 V, and the maximum input to this pin is 14.0 V.
J1-3	VREN	This pin is the enable input for the DM2200-916VM-1 on-board regulator. To enable the on-board regulator, connect this pin to J1-2. To disable the on-board regulator, connect this pin to ground.
J1-4	VDD	This pin is connected to the DM2200-916VM-1 positive power supply buss. When the module is powered from the on-board regulator, this pin can provide up to 5 mA of current at 3.0 Vdc. Note this current adds to the receive, transmit and sleep currents listed in the specifications on Page 1. The external load must not impress more than 10 mV peak -peak ripple on the supply buss. If the on-board regulator is disabled, the module can be powered through this pin by an external 2.9 to 3.7 Vdc source (maximum ripple 10 mV peak-peak).
J1-5	TD0	This pin is only used for factory programming. It must be left unconnected in normal operation.
J1-6	TDI	This pin is only used for factory programming. It must be left unconnected in normal operation.
J1-7	TWS	This pin is only used for factory programming. It must be left unconnected in normal operation.
J1-8	TCK	This pin is only used for factory programming. It must be left unconnected in normal operation.
J1-9	RST	This pin is only used for factory programming. It must be left unconnected in normal operation (reset is CFG3).
J1-10	CFG0	This pin is an auxiliary digital I/O pin. The default configuration of this pin is a digital output.
J1-11	CFG1	This pin is an auxiliary digital I/O pin. The default configuration of this pin is a digital output.
J1-12	CFG2	This pin is an auxiliary digital I/O pin. The default configuration of this pin is a digital output.
J1-13	CFG3	This pin is a software reset pin. Logic high is normal operation. Logic low invokes software resets.
J1-14	GND	This pin is connected to ground.
J2-1	GND	This pin is connected to ground.
J2-2	RXD	This pin is the serial data input (CMOS).
J2-3	TXD	This pin is the serial data output (CMOS).
J2-4	CTS	This pin is a serial data flow control input (CMOS).
J2-5	RTS	This pin is a serial data flow control output (CMOS).
J2-6	GP0/RSSI	This pin is an I/O pin dedicated to monitoring the RSSI circuit output. It is configured as an analog-to-digital converter input. The RSSI signal can also be monitored externally at this pin.
J2-7	GP1	This pin is an I/O pin. The default configuration of this pin is a digital input with optional pulse counting capability. A 24-bit register is maintained within the DM2200 to accumulate pulse counts. This input can count up to 10 pulses/second. This input supports interrupts, allowing pulse counting or alarm monitoring while the DM2200 is operating in a low current "sleep" mode.
J2-8	GP2	This pin is an I/O pin. The default configuration of this pin is a digital input. This input supports interrupts, allowing alarm monitoring while the DM2200 is operating in a low current "sleep" mode.
J2-9	GP3	This pin is an I/O pin. The default configuration of this pin is a digital input.
J2-10	GP4	This pin is an I/O pin. The default configuration of this pin is a digital output.
J2-11	GP5	This pin is an I/O pin. The default configuration of this pin is a digital output.
J2-12	GP6	This pin is an I/O pin. The default configuration of this pin is an analog-to-digital converter input.
J2-13	GP7	This pin is an I/O pin. The default configuration of this pin is an analog-to-digital converter input.
J2-14	GND	This pin is connected to ground.

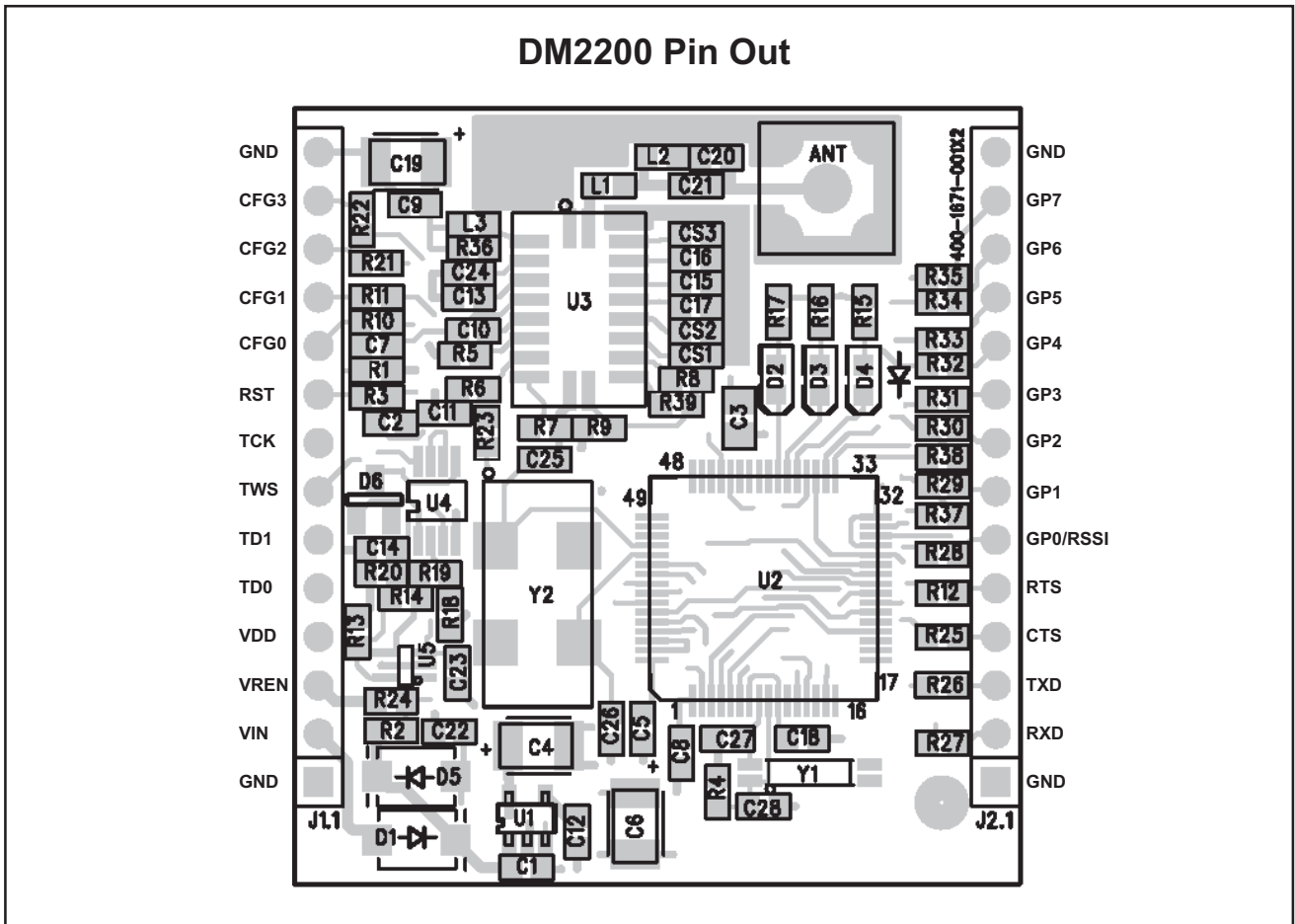

Figure 2



CAUTION: Electrostatic Sensitive Device. Observe precautions when handling.

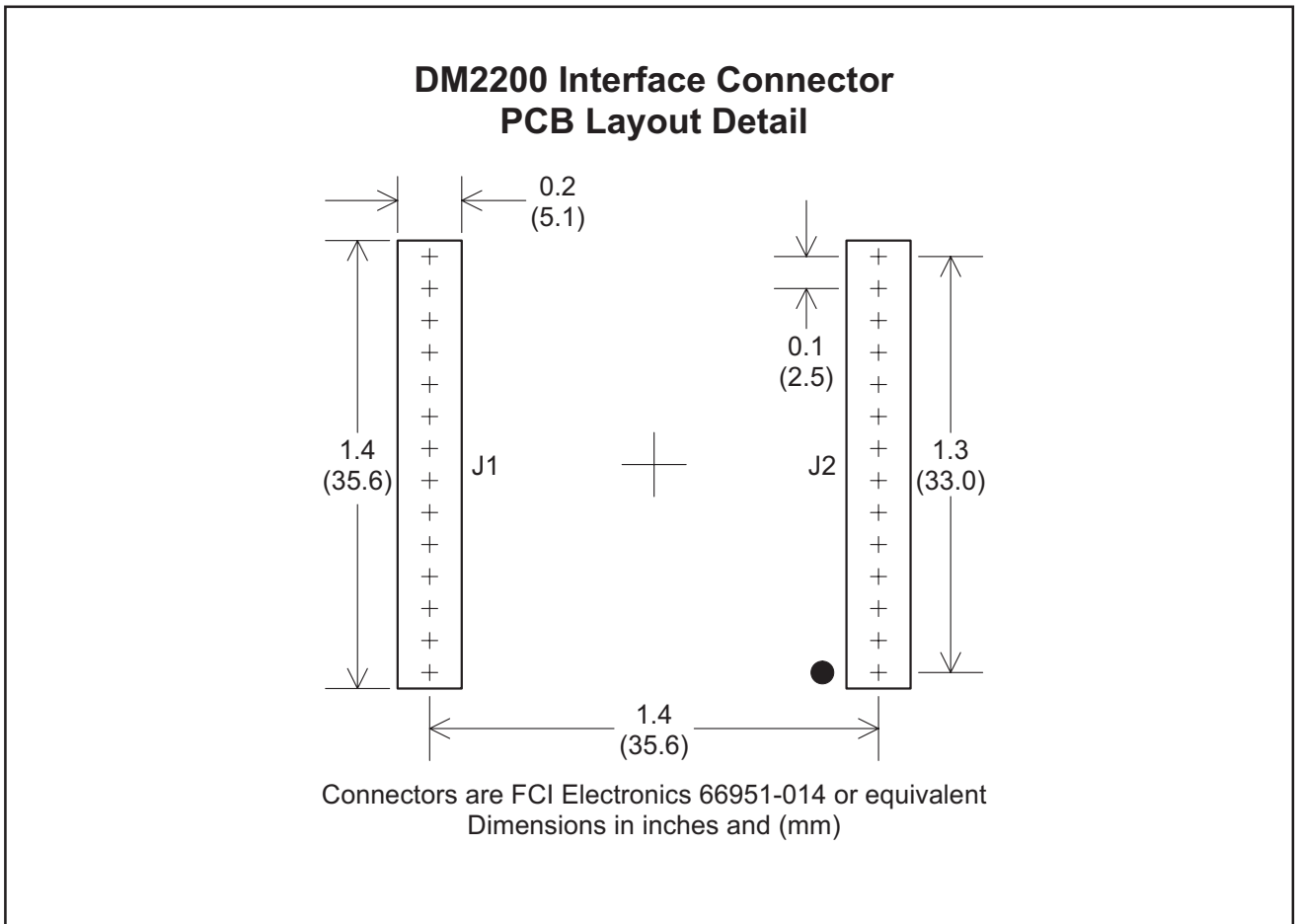

Figure 3

Note: Specifications subject to change without notice.