

Excellent Integrated System Limited

Stocking Distributor

Click to view price, real time Inventory, Delivery & Lifecycle Information:

[Molex Connector Corporation](#)
[0640010300](#)

For any questions, you can email us directly:

sales@integrated-circuit.com

RHT 1993 Hand Crimp Tool

| | | |
|--|---|---|
| Hand Crimp Tool InsulKrimp™ |  Application Tooling Specification Sheet |  Order No. 64001-0300 Engineering No. RHT 1993 |
|--|---|---|

FEATURES

- A full cycle ratcheting hand tool ensures complete crimps
- Long handles for comfortable crimping with reduced crimping force
- A precision user-friendly terminal locator wire stop holds terminals in the proper crimping position for each of the three nests
- 3-nested tool eliminates the need for additional tools

SCOPE

InsulKrimp™ Terminals and Splices 10 - 22 AWG, (Rings, Spades, Hooks, Block Spades and Flanged Spades).

Testing

Mechanical

The tensile test, or pull test, is a means of evaluating the mechanical properties of the crimped connections. The following charts show the UL specifications for various wire sizes. The tensile strength is shown in pounds and indicates the minimum acceptable force to break or separate the terminal from the conductor.

| Wire Size (AWG) | *UL - 486 A | *UL - 486 C |
|-----------------|-------------|-------------|
| 22 | 8 | 8 |
| 20 | 13 | 10 |
| 18 | 20 | 10 |
| 16 | 30 | 15 |
| 14 | 50 | 25 |
| 12 | 70 | 35 |
| 10 | 80 | 40 |

*UL - 486 A - Terminals (Copper conductors only)

*UL - 486 C - Butt Splices

The following is a partial list of the product part numbers and their specifications that this tool is designed to run. We will be adding to this list and an up to date copy is available on www.molex.com

| Wire Size: 18 - 22 AWG 0.80 - 0.35mm ² | | | | | |
|---|------------------------|-------------------|------|----------------------|------|
| Terminal No. | Terminal Eng No. (REF) | Wire Strip Length | | Insulation Dia. Max. | |
| | | In. | mm | In. | mm |
| 19034-0001 | A-769 | .310 | 7.94 | .145 | 3.68 |
| 19034-0002 | A-259X | .310 | 7.94 | .145 | 3.68 |
| 19034-0005 | A-269X | .310 | 7.94 | .145 | 3.68 |
| 19070-0001 | AA-2111-02X | .234 | 5.95 | .145 | 3.68 |
| 19070-0003 | AA-2111-04X | .234 | 5.95 | .145 | 3.68 |

| Wire Size: 18 - 22 AWG 0.80 - 0.35mm ² | | | | | |
|---|------------------------|-------------------|------|----------------------|------|
| Terminal No. | Terminal Eng No. (REF) | Wire Strip Length | | Insulation Dia. Max. | |
| | | In. | mm | In. | mm |
| 19070-0005 | AA-220-02X | .230 | 5.95 | .145 | 3.68 |
| 19070-0007 | AA-220-04X | .230 | 5.95 | .145 | 3.68 |
| 19070-0009 | AA-220-06X | .230 | 5.95 | .145 | 3.68 |
| 19070-0011 | AA-221-06X | .230 | 5.95 | .145 | 3.68 |
| 19070-0013 | AA-221-08X | .230 | 5.95 | .145 | 3.68 |

RHT 1993 Hand Crimp Tool

| Wire Size: 18 – 22 AWG 0.80 – 0.35mm ² | | | | | | Wire Size: 18 – 22 AWG 0.80 – 0.35mm ² | | | | | |
|---|------------------------|-------------------|------|----------------------|------|---|------------------------|-------------------|------|----------------------|------|
| Terminal No. | Terminal Eng No. (REF) | Wire Strip Length | | Insulation Dia. Max. | | Terminal No. | Terminal Eng No. (REF) | Wire Strip Length | | Insulation Dia. Max. | |
| | | In. | mm | In. | mm | | | In. | mm | In. | mm |
| 19070-0015 | AA-221-10X | .230 | 5.95 | .145 | 3.68 | 19092-0035 | AA-698-08X | .234 | 5.95 | .145 | 3.68 |
| 19070-0016 | AA-221-10XR90 | .234 | 5.95 | .145 | 3.68 | 19092-0037 | AA-698-10X | .234 | 5.95 | .145 | 3.68 |
| 19070-0018 | AA-221-10XT45 | .234 | 5.95 | .145 | 3.68 | 19099-0001 | AA-2190-06X | .230 | 5.95 | .145 | 3.68 |
| 19070-0019 | AA-221-209X | .234 | 5.95 | .145 | 3.68 | 19099-0003 | AA-2191-08X | .230 | 5.95 | .145 | 3.68 |
| 19070-0021 | AA-222-10X | .230 | 5.95 | .145 | 3.68 | 19099-0005 | AA-2192-10X | .230 | 5.95 | .145 | 3.68 |
| 19070-0023 | AA-222-14X | .230 | 5.95 | .145 | 3.68 | 19099-0007 | AA-2704-05X | .230 | 5.95 | .145 | 3.68 |
| 19070-0026 | AA-222-56X | .230 | 5.95 | .145 | 3.68 | 19099-0009 | AA-2704-06X | .230 | 5.95 | .145 | 3.68 |
| 19070-0029 | AA-226-10X | .234 | 5.95 | .145 | 3.68 | 19099-0011 | AA-2705-08X | .234 | 5.95 | .145 | 3.68 |
| 19070-0031 | AA-226-14X | .234 | 5.95 | .145 | 3.68 | 19099-0012 | AA-2706-10X | .234 | 5.95 | .145 | 3.68 |
| 19070-0033 | AA-226-38X | .230 | 5.95 | .145 | 3.68 | 19099-0013 | AA-2714-08X | .230 | 5.95 | .145 | 3.68 |
| 19070-0036 | AA-226-56X | .234 | 5.95 | .145 | 3.68 | 19099-0015 | AA-2715-10X | .230 | 5.95 | .145 | 3.68 |
| 19070-0038 | AA-232-04X | .230 | 5.95 | .145 | 3.68 | 19099-0081 | AA-2704-04X | .234 | 5.95 | .145 | 3.68 |
| 19070-0040 | AA-232-06X | .230 | 5.95 | .145 | 3.68 | 19121-0001 | AA-2108-02X | .234 | 5.95 | .145 | 3.68 |
| 19070-0044 | AA-232-08X | .230 | 5.95 | .145 | 3.68 | 19121-0002 | AA-2108-04X | .230 | 5.95 | .145 | 3.68 |
| 19070-0051 | AA-233-10X | .230 | 5.95 | .145 | 3.68 | 19121-0004 | AA-215-04X | .234 | 5.95 | .145 | 3.68 |
| 19070-0094 | AA-220-06XR90 | .234 | 5.95 | .145 | 3.68 | 19121-0005 | AA-215-06X | .230 | 5.95 | .145 | 3.68 |
| 19071-0001 | AA-6111-02X | .234 | 5.95 | .145 | 3.68 | 19121-0007 | AA-215-08X | .230 | 5.95 | .145 | 3.68 |
| 19071-0003 | AA-6111-04X | .234 | 5.95 | .145 | 3.68 | 19121-0009 | AA-215-10X | .230 | 5.95 | .145 | 3.68 |
| 19071-0005 | AA-620-02X | .234 | 5.95 | .145 | 3.68 | 19121-0011 | AA-2461-04X | .234 | 5.95 | .145 | 3.68 |
| 19071-0007 | AA-620-04X | .234 | 5.95 | .145 | 3.68 | 19121-0012 | AA-2461-06X | .234 | 5.95 | .145 | 3.68 |
| 19071-0009 | AA-620-06X | .234 | 5.95 | .145 | 3.68 | 19121-0013 | AA-2461-08X | .234 | 5.95 | .145 | 3.68 |
| 19071-0011 | AA-621-06X | .234 | 5.95 | .145 | 3.68 | 19121-0014 | AA-2461-10X | .234 | 5.95 | .145 | 3.68 |
| 19071-0013 | AA-621-08X | .234 | 5.95 | .145 | 3.68 | 19121-0015 | AA-290-06X | .234 | 5.95 | .145 | 3.68 |
| 19071-0015 | AA-621-10X | .234 | 5.95 | .145 | 3.68 | 19121-0016 | AA-290-08X | .234 | 5.95 | .145 | 3.68 |
| 19071-0017 | AA-622-10X | .234 | 5.95 | .145 | 3.68 | 19121-0017 | AA-290-10X | .234 | 5.95 | .145 | 3.68 |
| 19071-0019 | AA-622-14X | .234 | 5.95 | .145 | 3.68 | 19121-0018 | AA-293-06X | .234 | 5.95 | .145 | 3.68 |
| 19071-0021 | AA-622-56X | .234 | 5.95 | .145 | 3.68 | 19121-0019 | AA-293-08X | .234 | 5.95 | .145 | 3.68 |
| 19071-0023 | AA-626-10X | .234 | 5.95 | .145 | 3.68 | 19121-0020 | AA-293-10X | .234 | 5.95 | .145 | 3.68 |
| 19071-0024 | AA-626-14X | .234 | 5.95 | .145 | 3.68 | 19121-0021 | AA-296-04X | .234 | 5.95 | .145 | 3.68 |
| 19071-0026 | AA-626-38X | .234 | 5.95 | .145 | 3.68 | 19121-0022 | AA-296-06X | .230 | 5.95 | .145 | 3.68 |
| 19071-0028 | AA-626-56X | .234 | 5.95 | .145 | 3.68 | 19121-0024 | AA-296-08X | .234 | 5.95 | .145 | 3.68 |
| 19071-0030 | AA-632-04X | .234 | 5.95 | .145 | 3.68 | 19122-0001 | AA-6108-02X | .234 | 5.95 | .145 | 3.68 |
| 19071-0032 | AA-632-06X | .234 | 5.95 | .145 | 3.68 | 19122-0003 | AA-6108-04X | .234 | 5.95 | .145 | 3.68 |
| 19071-0034 | AA-632-08X | .234 | 5.95 | .145 | 3.68 | 19122-0005 | AA-615-04X | .234 | 5.95 | .145 | 3.68 |
| 19071-0040 | AA-633-10X | .234 | 5.95 | .145 | 3.68 | 19122-0007 | AA-615-06X | .234 | 5.95 | .145 | 3.68 |
| 19080-0001 | A-2006-MSX | .310 | 7.94 | .145 | 3.68 | 19122-0009 | AA-615-08X | .234 | 5.95 | .145 | 3.68 |
| 19090-0007 | AA-2110-02X | .230 | 5.95 | .145 | 3.68 | 19122-0011 | AA-690-06X | .234 | 5.95 | .145 | 3.68 |
| 19090-0009 | AA-2110-04X | .234 | 5.95 | .145 | 3.68 | 19122-0013 | AA-690-08X | .234 | 5.95 | .145 | 3.68 |
| 19090-0011 | AA-214-04X | .234 | 5.95 | .145 | 3.68 | 19122-0015 | AA-690-10X | .234 | 5.95 | .145 | 3.68 |
| 19090-0013 | AA-214-06X | .230 | 5.95 | .145 | 3.68 | 19122-0017 | AA-693-06X | .234 | 5.95 | .145 | 3.68 |
| 19090-0024 | AA-292-06X | .234 | 5.95 | .145 | 3.68 | 19122-0019 | AA-693-08X | .234 | 5.95 | .145 | 3.68 |
| 19090-0026 | AA-292-08X | .234 | 5.95 | .145 | 3.68 | 19122-0021 | AA-693-10X | .234 | 5.95 | .145 | 3.68 |
| 19090-0028 | AA-292-10X | .234 | 5.95 | .145 | 3.68 | 19122-0023 | AA-696-04X | .234 | 5.95 | .145 | 3.68 |
| 19090-0030 | AA-295-06X | .234 | 5.95 | .145 | 3.68 | 19122-0025 | AA-696-06X | .234 | 5.95 | .145 | 3.68 |
| 19090-0032 | AA-295-08X | .234 | 5.95 | .145 | 3.68 | 19131-0027 | AA-294-10X | .230 | 5.95 | .145 | 3.68 |
| 19090-0034 | AA-295-10X | .234 | 5.95 | .145 | 3.68 | 19131-0028 | AA-294-08X | .234 | 5.95 | .145 | 3.68 |
| 19090-0036 | AA-298-04X | .234 | 5.95 | .145 | 3.68 | 19131-0029 | AA-294-06X | .234 | 5.95 | .145 | 3.68 |
| 19090-0038 | AA-298-06X | .234 | 5.95 | .145 | 3.68 | 19131-0031 | AA-238-06X | .230 | 5.95 | .145 | 3.68 |
| 19090-0040 | AA-298-08X | .234 | 5.95 | .145 | 3.68 | 19131-0033 | AA-238-04X | .234 | 5.95 | .145 | 3.68 |
| 19090-0042 | AA-298-10X | .234 | 5.95 | .145 | 3.68 | 19131-0034 | AA-234-10X | .230 | 5.95 | .145 | 3.68 |
| 19092-0001 | AA-605-04X | .234 | 5.95 | .145 | 3.68 | 19131-0036 | AA-234-08X | .230 | 5.95 | .145 | 3.68 |
| 19092-0003 | AA-605-06X | .234 | 5.95 | .145 | 3.68 | 19131-0038 | AA-234-06X | .230 | 5.95 | .145 | 3.68 |
| 19092-0009 | AA-6110-02X | .234 | 5.95 | .145 | 3.68 | 19131-0039 | AA-234-04X | .234 | 5.95 | .145 | 3.68 |
| 19092-0011 | AA-6110-04X | .234 | 5.95 | .145 | 3.68 | 19131-0042 | AA-2118-06X | .230 | 5.95 | .145 | 3.68 |
| 19092-0013 | AA-614-04X | .234 | 5.95 | .145 | 3.68 | 19131-0045 | AA-2109-04X | .230 | 5.95 | .145 | 3.68 |
| 19092-0015 | AA-614-06X | .234 | 5.95 | .145 | 3.68 | 19131-0047 | AA-2109-02X | .230 | 5.95 | .145 | 3.68 |
| 19092-0017 | AA-614-08X | .234 | 5.95 | .145 | 3.68 | 19133-0001 | AA-634-04X | .234 | 5.95 | .145 | 3.68 |
| 19092-0019 | AA-692-06X | .234 | 5.95 | .145 | 3.68 | 19133-0002 | AA-634-06X | .234 | 5.95 | .145 | 3.68 |
| 19092-0021 | AA-692-08X | .234 | 5.95 | .145 | 3.68 | 19133-0003 | AA-634-08X | .234 | 5.95 | .145 | 3.68 |
| 19092-0023 | AA-692-10X | .234 | 5.95 | .145 | 3.68 | 19133-0004 | AA-634-10X | .234 | 5.95 | .145 | 3.68 |
| 19092-0025 | AA-695-06X | .234 | 5.95 | .145 | 3.68 | 19144-0001 | AA-235-06X | .230 | 5.95 | .145 | 3.68 |
| 19092-0027 | AA-695-08X | .234 | 5.95 | .145 | 3.68 | 19144-0003 | AA-235-08X | .230 | 5.95 | .145 | 3.68 |
| 19092-0029 | AA-695-10X | .234 | 5.95 | .145 | 3.68 | 19144-0005 | AA-235-10X | .230 | 5.95 | .145 | 3.68 |
| 19092-0031 | AA-698-04X | .234 | 5.95 | .145 | 3.68 | 19144-0007 | AA-291-06X | .234 | 5.95 | .145 | 3.68 |
| 19092-0033 | AA-698-06X | .234 | 5.95 | .145 | 3.68 | 19144-0008 | AA-291-08X | .234 | 5.95 | .145 | 3.68 |

RHT 1993 Hand Crimp Tool

| Wire Size: 18 – 22 AWG 0.80 – 0.35mm ² | | | | | |
|---|------------------------|-------------------|------|----------------------|------|
| Terminal No. | Terminal Eng No. (REF) | Wire Strip Length | | Insulation Dia. Max. | |
| | | In. | mm | In. | mm |
| 19144-0009 | AA-291-10X | .234 | 5.95 | .145 | 3.68 |
| 19144-0010 | AA-297-04X | .234 | 5.95 | .145 | 3.68 |
| 19144-0011 | AA-297-06X | .234 | 5.95 | .145 | 3.68 |
| 19144-0012 | AA-297-08X | .234 | 5.95 | .145 | 3.68 |
| 19145-0001 | AA-6109-02X | .234 | 5.95 | .145 | 3.68 |
| 19145-0003 | AA-6109-04X | .234 | 5.95 | .145 | 3.68 |
| 19145-0011 | AA-635-06X | .234 | 5.95 | .145 | 3.68 |
| 19145-0013 | AA-635-08X | .234 | 5.95 | .145 | 3.68 |
| 19145-0015 | AA-635-10X | .234 | 5.95 | .145 | 3.68 |
| 19145-0017 | AA-638-04X | .234 | 5.95 | .145 | 3.68 |
| 19145-0019 | AA-638-06X | .234 | 5.95 | .145 | 3.68 |
| 19145-0022 | AA-691-06X | .234 | 5.95 | .145 | 3.68 |
| 19145-0024 | AA-691-08X | .234 | 5.95 | .145 | 3.68 |
| 19145-0026 | AA-691-10X | .234 | 5.95 | .145 | 3.68 |
| 19145-0028 | AA-694-06X | .234 | 5.95 | .145 | 3.68 |
| 19145-0030 | AA-694-08X | .234 | 5.95 | .145 | 3.68 |
| 19145-0032 | AA-694-10X | .234 | 5.95 | .145 | 3.68 |
| 19145-0034 | AA-697-04X | .234 | 5.95 | .145 | 3.68 |
| 19145-0036 | AA-697-06X | .234 | 5.95 | .145 | 3.68 |
| 19145-0038 | AA-697-08X | .234 | 5.95 | .145 | 3.68 |
| 19154-0004 | A-245X | .310 | 7.94 | .145 | 3.68 |
| 19154-0011 | AS-V-345X | .280 | 7.15 | .145 | 3.68 |
| 19164-0009 | SA-259 | .281 | 7.14 | | |
| 19164-0010 | SA-269 | .281 | 7.14 | | |
| 19179-0002 | AA-210-06X | .230 | 5.95 | .145 | 3.68 |
| 19179-0006 | AA-210-10X | .230 | 5.95 | .145 | 3.68 |
| 19182-0001 | AA-610-06X | .234 | 5.95 | .145 | 3.68 |
| 19182-0003 | AA-610-08X | .234 | 5.95 | .145 | 3.68 |
| 19182-0005 | AA-610-10X | .234 | 5.95 | .145 | 3.68 |
| 19202-0010 | AS-932 | .310 | 7.94 | | 0.00 |
| 19202-0011 | AS-932-DK | .310 | 7.94 | | |
| 19202-0062 | A-945 | .310 | 7.94 | .145 | 3.68 |
| 19202-0063 | A-945-DK | .310 | 7.94 | .145 | 3.68 |
| 19204-0003 | A-2XCX | .310 | 7.94 | | |
| 19204-0004 | A-2YCX | .310 | 7.94 | | |
| 19207-0002 | AS-N-302 | .280 | 7.15 | .120 | 3.05 |
| 19212-0003 | WP-2218X | .190 | 4.76 | .145 | 3.68 |

| Wire Size: 14 – 16 AWG 2.00 – 1.30mm ² | | | | | |
|---|------------------------|-------------------|------|----------------------|------|
| Terminal No. | Terminal Eng No. (REF) | Wire Strip Length | | Insulation Dia. Max. | |
| | | In. | mm | In. | mm |
| 19034-0004 | B-789 | .250 | 6.35 | | 0.00 |
| 19034-0007 | B-279X | .310 | 7.94 | .175 | 4.45 |
| 19070-0059 | BB-218-38X | .230 | 5.95 | .175 | 4.45 |
| 19070-0063 | BB-218-56X | .230 | 5.95 | .175 | 4.45 |
| 19070-0065 | BB-223-02X | .230 | 5.95 | .175 | 4.45 |
| 19070-0067 | BB-223-04X | .230 | 5.95 | .175 | 4.45 |
| 19070-0069 | BB-223-06X | .230 | 5.95 | .175 | 4.45 |
| 19070-0071 | BB-223-08X | .230 | 5.95 | .175 | 4.45 |
| 19070-0073 | BB-225-10X | .230 | 5.95 | .175 | 4.45 |
| 19070-0075 | BB-225-14X | .230 | 5.95 | .175 | 4.45 |
| 19070-0078 | BB-225-56X | .230 | 5.95 | .175 | 4.45 |
| 19070-0083 | BB-237-06X | .230 | 5.95 | .175 | 4.45 |
| 19070-0086 | BB-237-08X | .230 | 5.95 | .175 | 4.45 |
| 19070-0090 | BB-237-10X | .230 | 5.95 | .175 | 4.45 |
| 19070-0099 | BB-239-08X | .230 | 5.95 | .175 | 4.45 |
| 19070-0102 | BB-239-10X | .230 | 5.95 | .175 | 4.45 |
| 19070-0105 | BB-239-10XX | .230 | 5.95 | .175 | 4.45 |
| 19070-0270 | BB-237-06XX | .230 | 5.95 | .175 | 4.45 |
| 19070-0271 | BB-239-08XX | .230 | 5.95 | .175 | 4.45 |
| 19070-0285 | BB-237-08XX | | 0.00 | .175 | 4.45 |
| 19070-0322 | BB-237-10XX | | 0.00 | .175 | 4.45 |
| 19080-0003 | B-2006-MSX | .310 | 7.94 | .170 | 4.32 |

| Wire Size: 14 – 16 AWG 2.00 – 1.30mm ² | | | | | |
|---|------------------------|-------------------|------|----------------------|------|
| Terminal No. | Terminal Eng No. (REF) | Wire Strip Length | | Insulation Dia. Max. | |
| | | In. | mm | In. | mm |
| 19090-0044 | BB-213-04X | .230 | 5.95 | .175 | 4.45 |
| 19090-0046 | BB-213-06X | .230 | 5.95 | .175 | 4.45 |
| 19090-0048 | BB-213-08X | .230 | 5.95 | .175 | 4.45 |
| 19090-0071 | BB-288-06X | .230 | 5.95 | .175 | 4.45 |
| 19090-0075 | BB-288-10X | .230 | 5.95 | .175 | 4.45 |
| 19099-0017 | BB-2193-06X | .230 | 5.95 | .175 | 4.45 |
| 19099-0019 | BB-2194-08X | .230 | 5.95 | .175 | 4.45 |
| 19099-0022 | BB-2195-10X | .230 | 5.95 | .175 | 4.45 |
| 19099-0025 | BB-2707-05X | .230 | 5.95 | .175 | 4.45 |
| 19099-0027 | BB-2707-06X | .230 | 5.95 | .175 | 4.45 |
| 19099-0032 | BB-2716-08X | .230 | 5.95 | .175 | 4.45 |
| 19099-0034 | BB-2717-10X | .230 | 5.95 | .175 | 4.45 |
| 19099-0077 | BB-2707-06XX | .230 | 5.95 | | 0.00 |
| 19121-0026 | BB-216-06X | .230 | 5.95 | .175 | 4.45 |
| 19121-0028 | BB-216-08X | .230 | 5.95 | .175 | 4.45 |
| 19121-0030 | BB-216-10X | .230 | 5.95 | .175 | 4.45 |
| 19121-0040 | BB-283-10X | .230 | 5.95 | .175 | 4.45 |
| 19131-0007 | BB-287-08X | .230 | 5.95 | .175 | 4.45 |
| 19131-0014 | BB-2781-10X | .230 | 5.95 | .175 | 4.45 |
| 19131-0018 | BB-2781-08X | .230 | 5.95 | .175 | 4.45 |
| 19131-0020 | BB-2781-06X | .230 | 5.95 | .175 | 4.45 |
| 19131-0023 | BB-2471-06X | .230 | 5.95 | .175 | 4.45 |
| 19131-0025 | BB-2471-04X | .230 | 5.95 | .175 | 4.45 |
| 19144-0013 | BB-207-04X | .230 | 5.95 | .175 | 4.45 |
| 19144-0015 | BB-207-06X | .230 | 5.95 | .175 | 4.45 |
| 19144-0018 | BB-224-06X | .230 | 5.95 | .175 | 4.45 |
| 19144-0020 | BB-224-08X | .230 | 5.95 | .175 | 4.45 |
| 19144-0024 | BB-227-08X | .230 | 5.95 | .175 | 4.45 |
| 19144-0026 | BB-227-10X | .230 | 5.95 | .175 | 4.45 |
| 19154-0015 | B-231X | .230 | 5.95 | .175 | 4.45 |
| 19154-0023 | BS-V-331X | .280 | 7.15 | | |
| 19164-0039 | SB-279 | .281 | 7.14 | | |
| 19164-0040 | SB-289 | .281 | 7.14 | | |
| 19179-0008 | BB-219-06X | .230 | 5.95 | .175 | 4.45 |
| 19179-0010 | BB-219-08X | .230 | 5.95 | .175 | 4.45 |
| 19179-0012 | BB-219-10X | .230 | 5.95 | .175 | 4.45 |
| 19202-0018 | B-931 | .310 | 7.94 | | 0.00 |
| 19202-0019 | B-931-DK | .310 | 7.94 | | |
| 19202-0026 | BS-942 | .310 | 7.94 | .199 | 5.05 |
| 19202-0027 | BS-942-DK | .310 | 7.94 | .199 | 5.05 |
| 19202-0031 | BS-N-331 | .280 | 7.15 | | |
| 19204-0013 | B-2XCX | .310 | 7.94 | | |
| 19204-0014 | B-2YCX | .310 | 7.94 | | |
| 19206-0004 | B-204X | .280 | 7.15 | .175 | 4.45 |
| 19207-0004 | BS-N-304 | .280 | 7.15 | .150 | 3.81 |
| 19127-0005 | WP-2614XC | .190 | 4.76 | .175 | 4.45 |

| Wire Size: 10 – 12 AWG 5.00 – 3.00mm ² | | | | | |
|---|------------------------|-------------------|------|----------------------|------|
| Terminal No. | Terminal Eng No. (REF) | Wire Strip Length | | Insulation Dia. Max. | |
| | | In. | mm | In. | mm |
| 19070-0109 | C-201-12X | .380 | 5.95 | .250 | 6.35 |
| 19070-0115 | C-201-76X | .380 | 5.95 | .250 | 6.35 |
| 19070-0119 | C-228-06X | .380 | 9.53 | .250 | 6.35 |
| 19070-0121 | C-228-08X | .380 | 9.53 | .250 | 6.35 |
| 19070-0123 | C-228-10X | .380 | 9.53 | .250 | 6.35 |
| 19070-0130 | C-230-10X | .380 | 9.53 | .250 | 6.35 |
| 19070-0132 | C-230-14X | .380 | 9.53 | .250 | 6.35 |
| 19070-0136 | C-230-56X | .380 | 9.53 | .250 | 6.35 |
| 19070-0143 | C-236-06X | .380 | 9.53 | .250 | 6.35 |
| 19070-0145 | C-236-08X | .380 | 9.53 | .250 | 6.35 |
| 19070-0150 | C-240-14X | .380 | 9.53 | .250 | 6.35 |
| 19070-0153 | C-240-38X | .380 | 9.53 | .250 | 6.35 |

RHT 1993 Hand Crimp Tool

| Wire Size: 10 – 12 AWG 5.00 – 3.00mm ² | | | | | |
|---|------------------------|-------------------|------|----------------------|------|
| Terminal No. | Terminal Eng No. (REF) | Wire Strip Length | | Insulation Dia. Max. | |
| | | In. | mm | In. | mm |
| 19070-0155 | C-240-56X | .380 | 9.53 | .250 | 6.35 |
| 19080-0005 | C-2006-MSX | .380 | 5.95 | .250 | 6.35 |
| 19090-0079 | C-2106-06X | .380 | 5.95 | .250 | 6.35 |
| 19090-0083 | C-212-08X | .380 | 9.53 | .250 | 6.35 |
| 19090-0085 | C-212-10X | .380 | 9.53 | .250 | 6.35 |
| 19099-0036 | C-2196-06X | .380 | 5.95 | .250 | 6.35 |
| 19099-0038 | C-2197-08X | .380 | 5.95 | .250 | 6.35 |
| 19099-0040 | C-2198-10X | .380 | 5.95 | .250 | 6.35 |
| 19099-0042 | C-2199-14X | .380 | 5.95 | .250 | 6.35 |
| 19099-0044 | C-2710-06X | .380 | 9.53 | .250 | 6.35 |
| 19099-0048 | C-2718-08X | .380 | 9.53 | .250 | 6.35 |
| 19099-0050 | C-2719-10X | .380 | 9.53 | .250 | 6.35 |
| 19121-0045 | C-2101-08X | .380 | 5.95 | .250 | 6.35 |
| 19121-0046 | C-2104-06X | .380 | 5.95 | .250 | 6.35 |
| 19121-0047 | C-2104-08X | .380 | 5.95 | .250 | 6.35 |
| 19121-0049 | C-2104-10X | .380 | 5.95 | .250 | 6.35 |
| 19121-0051 | C-217-06X | .380 | 5.95 | .250 | 6.35 |
| 19121-0053 | C-217-08X | .380 | 5.95 | .250 | 6.35 |
| 19121-0056 | C-217-10X | .380 | 0.00 | .250 | 6.35 |
| 19131-0002 | C-2105-10X | .380 | 5.95 | .250 | 6.35 |

| Wire Size: 10 – 12 AWG 5.00 – 3.00mm ² | | | | | |
|---|------------------------|-------------------|------|----------------------|------|
| Terminal No. | Terminal Eng No. (REF) | Wire Strip Length | | Insulation Dia. Max. | |
| | | In. | mm | In. | mm |
| 19131-0004 | C-2105-08X | .380 | 5.95 | .250 | 6.35 |
| 19131-0006 | C-2105-06X | .380 | 5.95 | .250 | 6.35 |
| 19144-0037 | C-241-06X | .380 | 9.53 | .250 | 6.35 |
| 19144-0039 | C-241-08X | .380 | 9.53 | .250 | 6.35 |
| 19144-0042 | C-241-10X | .380 | 9.53 | .250 | 6.35 |
| 19144-0046 | C-268-14X | .380 | 9.53 | .265 | 6.73 |
| 19154-0028 | C-246X | .230 | 5.95 | .250 | 6.35 |
| 19154-0037 | CS-V-346X | .280 | 7.15 | .250 | 6.35 |
| 19179-0014 | C-211-06X | .380 | 9.53 | .250 | 6.35 |
| 19179-0019 | C-211-10X | .380 | 7.15 | .250 | 6.35 |
| 19202-0045 | CS-952 | .360 | 9.13 | .250 | 6.35 |
| 19202-0046 | CS-952-DK | .360 | 9.13 | .250 | 6.35 |
| 19202-0049 | CS-N-346 | .360 | 9.13 | | |
| 19202-0052 | CS-N-346X | .360 | 9.13 | | |
| 19204-0025 | C-2XCX | .380 | 9.53 | | |
| 19204-0026 | C-2YCX | .380 | 9.53 | .210 | 5.33 |
| 19206-0008 | C-203X | .280 | 5.95 | | 0.00 |
| 19207-0005 | CS-N-303 | .280 | 7.14 | .260 | 6.60 |
| 19212-0001 | WP-2210X | .280 | 7.15 | .250 | 6.35 |

OPERATION

Open the tool by first closing the jaws sufficiently for the ratchet mechanism to release.

Crimping Terminals

1. Push up on the locator blade and position the terminal with the barrel facing up into the proper color-coded nest with front edge of the barrel against the locator. See Figure 1. Release the locator blade to hold the terminal in position.
2. Partially close the tool to hold the terminal in place. See Figure 2.
3. Insert the properly stripped wire into the terminal barrel. See Figure 2 and 3. The wires end should butt against the wire stop position of the locator. Cycle the tool.

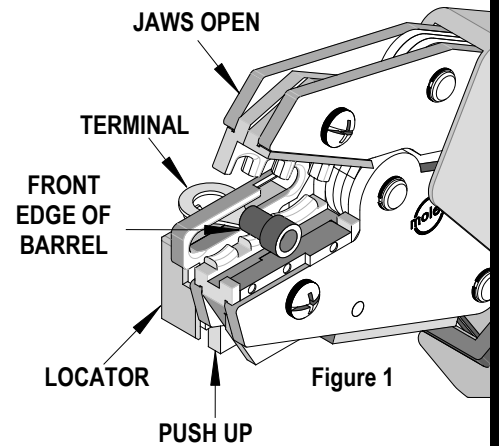

Note: The tamper proof ratchet action will not release the tool until it has been fully closed.

4. Lift the locator blade or wire stop and remove the crimped terminal. Inspect for proper crimp location. Locator is adjustable up and down to keep terminals straight after crimping.
5. When crimping butt splices, the locator must be removed and the splice visually aligned with the tooling 1/16" inside the tooling inserts. See Figure 4.

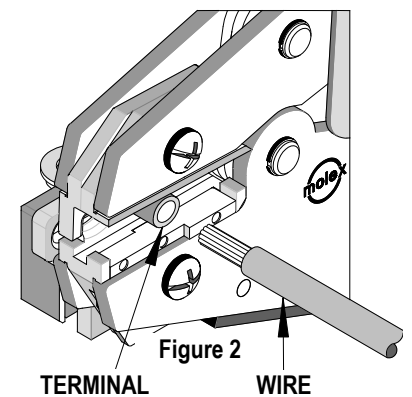

RHT 1993 Hand Crimp Tool

Note: Whenever crimping without the locator, make sure the seam of the terminal is oriented up or down in the tool if using unbrazed product, as this will provide higher pull force values.

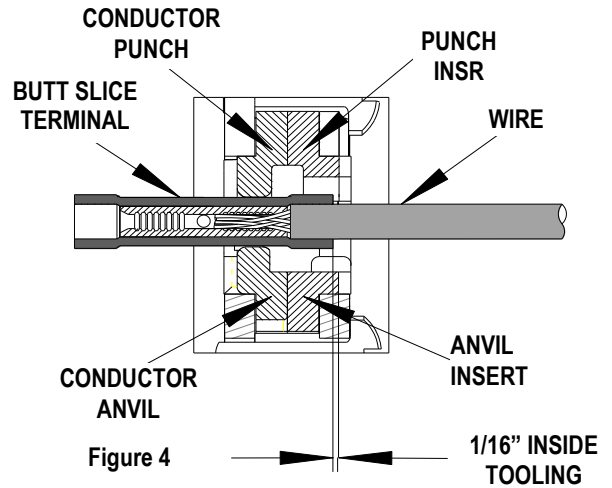
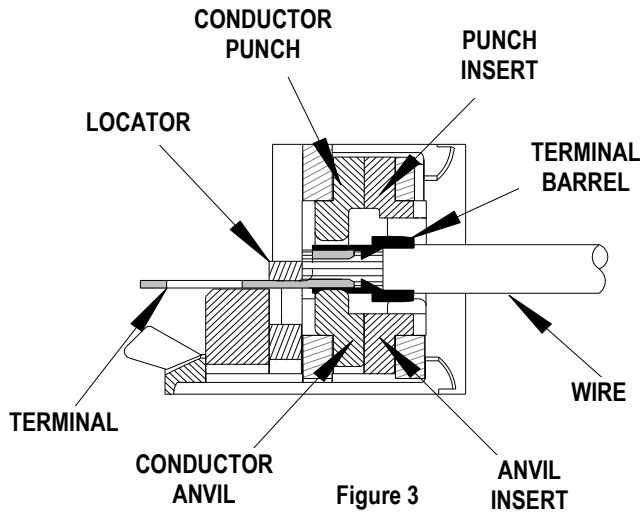

Maintenance

It is recommended that each operator of the tool be made aware of, and responsible for, the following maintenance steps:

1. Remove dust, moisture and other contaminants with a clean brush, or soft, lint-free cloth.
2. Do not use any abrasive materials that could damage the tool.
3. Make certain all pins; pivot points and bearing surfaces are protected with a thin coat of high quality machine oil. Do not oil excessively. The 64001-0300 (RHT-1993) was engineered for durability, but like any fine piece of equipment it needs cleaning and lubrication for a maximum service life of trouble-free crimping. A light oil, such as 30 weight automotive oil used at the oil points shown in Figure 5, every 5,000 crimps or 3 months will significantly enhance the tool life and ensure a stable calibration.
4. When tool is not in use, keep the handles closed to prevent objects from becoming lodged in the crimping dies, and store the tool in a clean, dry area.

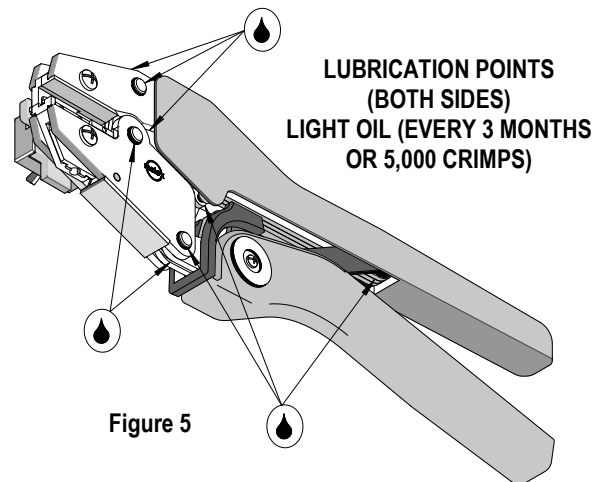

Miscrimps or Jams

Should this tool ever become stuck or jammed in a partially closed position, **Do Not** force the handles open or closed. The tool will open easily by lifting the ratchet release lever (See Figure 6).

RHT 1993 Hand Crimp Tool

How to Adjust Tool Preload (See Figure 6)

Over the life of the tool, it may be necessary to adjust tool handle preload force. Listed below are the steps required to adjust the crimping force of the hand tool to obtain proper crimp conditions:

1. Remove the screw and plastic cover washer. Note the setting wheel position.
2. Lift the setting wheel off the axle. Turn the eccentric axle with a screwdriver.
3. Turning the eccentric axle counter-clockwise (CCW) will increase handle force.
4. Replace the setting wheel to the axle, aligning the nearest notch in the setting wheel to the dowel pin.
5. Replace the plastic cover washer and screw.
6. Check the crimp specifications after tool handle preload force is adjusted.

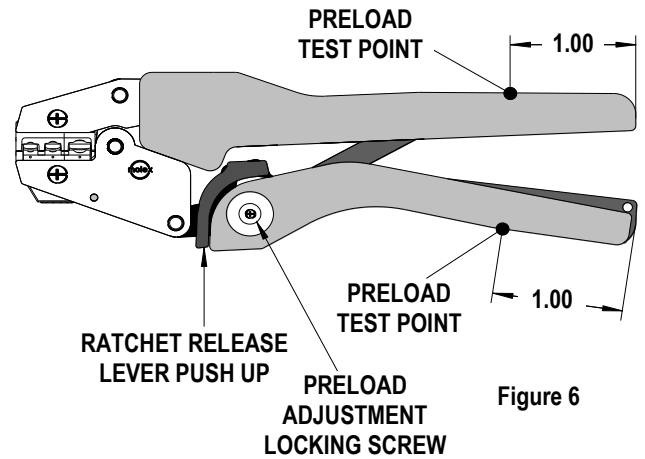
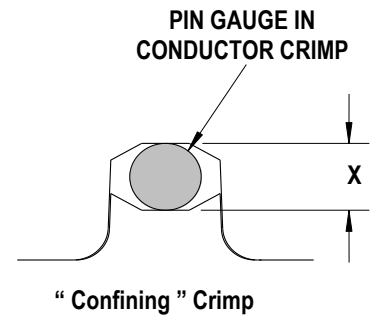

Figure 6

Tool Calibration

A Certificate of Calibration (see last page) was supplied with the tool. To recalibrate this tool, pin gauge measurements should be taken in each conductor nest and compared to this chart. The tool should be lubricated prior to recalibration to ensure consistent measurements. Handle preload is factory set to 25-45 LBS. See How to Adjust Tool Preload (see Figure 6) to recalibrate.



| Nest Color Code | Wire Range | | "X" Dimension Conductor Crimp | | | Crimp Inspection Marking |
|-----------------|------------|-----------------|-------------------------------|------|-------|--------------------------|
| | AWG | mm ² | Mean | Go | No Go | |
| Red | 18 - 22 | 0.35 - 0.80 | .108 | .104 | .112 | O |
| Blue | 14 - 16 | 1.30 - 2.00 | .117 | .112 | .122 | OO |
| Yellow | 10 - 12 | 3.30 - 5.00 | .147 | .143 | .152 | O |

CAUTION: Repetitive use of this tool should be avoided.

Warranty

This tool is for electrical terminal crimping purposes only. This tool is made of the best quality materials. All vital components are long-life tested. All tools are warranted to be free of manufacturing defects for a period of **30 days**. Should such a defect occur, we will repair or exchange the tool free of charge. This repair or exchange will not be applicable to altered, misused, or damaged tools. This tool is designed for hand use only. Any clamping, fixturing, or use of handle extensions voids this warranty.

Hand held crimping tools are intended for low volume, prototyping, or repair requirements only.

CAUTION: Molex crimp specifications are valid only when used with Molex terminals, applicators and tooling.

RHT 1993 Hand Crimp Tool

PARTS LIST

| Item | Order No | Description | Quantity |
|--|------------|--|------------|
| | 64001-0300 | Hand Crimp Tool | (Figure 7) |
| 1 | 64000-0076 | Repair Kit (Springs, Pins and E-Rings) | 1 |
| 2 | 63810-0000 | Handle | 1 |
| 3 | 64005-0175 | Locator Assembly | 1 |
| 4 | 64001-0370 | Tooling Kit | 1 |
| Tooling Kit Only | | | |
| 5 | 64001-0114 | Conductor Punch | 1 |
| 6 | 64001-0112 | Conductor Anvil | 1 |
| 7 | 64001-0312 | Insert Punch | 1 |
| 8 | 64001-0311 | Insert Anvil | 1 |
| 9 | N/A | 4 mm Dia. by 5.0 mm Lg.Roll Pins | 2** |
| ** Available from an Industrial supply company such as MSC (1-800-645-7270). | | | |

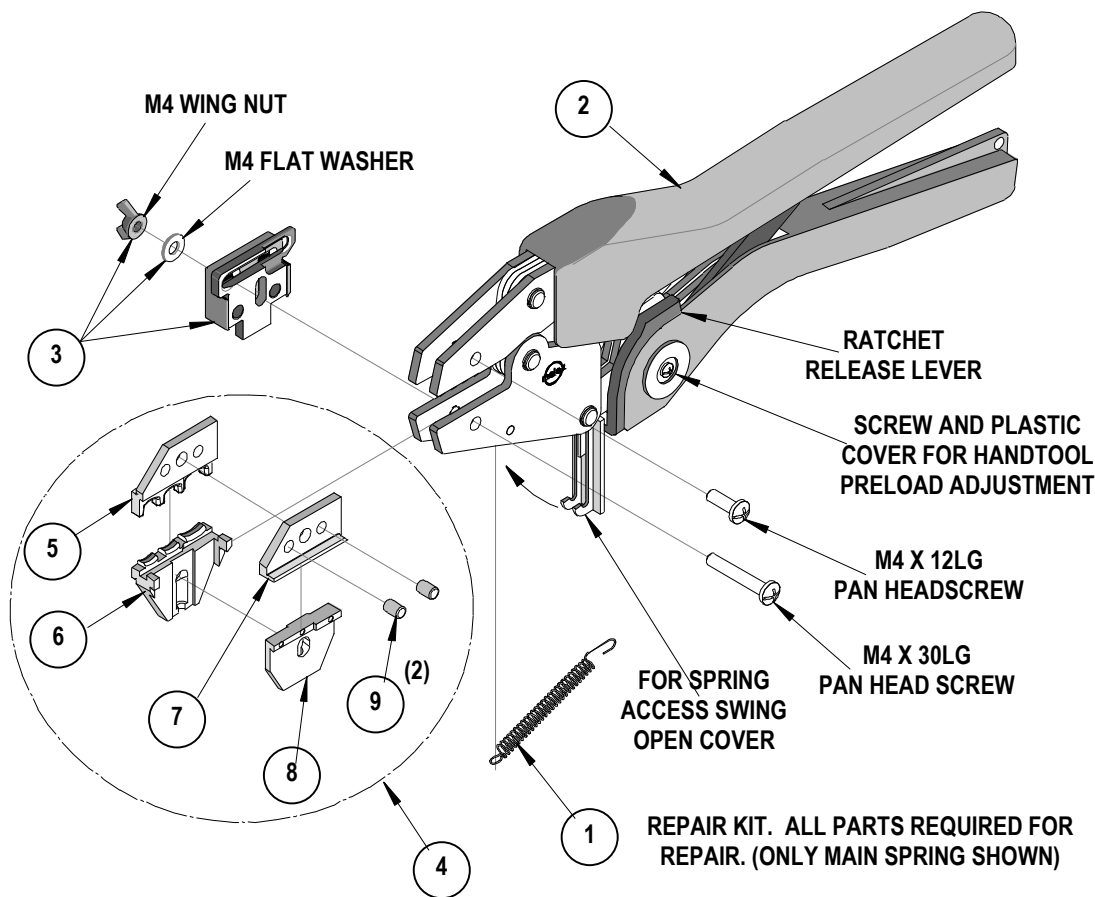

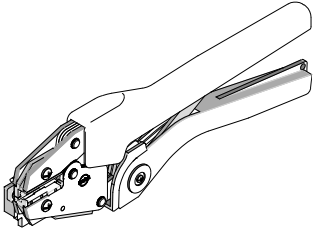

Figure 7

RHT 1993 Hand Crimp Tool

| | | |
|--|---|---|
| Hand Crimp Tool InsulKrimp™ |  |  |
| | Certificate of Calibration | |

Tool Order Number _____

Tool Eng. Number _____

Tool Revision _____

Serial Number _____

Date of Manufacture _____

Handle Load Range at 1 inch from the Tips = _____

Actual = _____

Pin Gauge of Conductor Nest/Nests or Slug height if the nest is the "F" Crimp style.

Range Conductor Nest # 1 = _____ Actual = _____

Range Conductor Nest # 2 = _____ Actual = _____

Range Conductor Nest # 3 = _____ Actual = _____

Technician _____

Date of Calibration _____

Calibration should be done every 5,000 cycles or 3 months.

Tools should be lubricated during this operation.

Visit our Web site at <http://www.molex.com>