

## Excellent Integrated System Limited

Stocking Distributor

Click to view price, real time Inventory, Delivery & Lifecycle Information:

[Diodes Incorporated](#)  
[ZNBG3010Q16TC](#)

For any questions, you can email us directly:

[sales@integrated-circuit.com](mailto:sales@integrated-circuit.com)

## FET BIAS CONTROLLER AND POLARITY SWITCH

ISSUE 1 - FEBRUARY 1998

**ZNBG3010**  
**ZNBG3011**

### DEVICE DESCRIPTION

The ZNBG series of devices are designed to meet the bias requirements of GaAs and HEMT FETs commonly used in satellite receiver LNBS, PMR cellular telephones etc. with a minimum of external components.

With the addition of two capacitors and a resistor, the devices provide drain voltage and current control for three external grounded source FETs, generating the regulated negative rail required for FET gate biasing whilst operating from a single supply. This negative bias, at -3 volts, can also be used to supply other external circuits.

The ZNBG3010/11 includes bias circuits to drive up to three external FETs. A control input to the device selects either one of two FETs as operational, the third FET is permanently active. This feature is particularly used as an LNB polarisation switch.

Drain current setting of the ZNBG3010/11 is user selectable over the range 0 to 15mA, this is achieved with addition of a single resistor. The series also offers the choice of drain voltage to be set for the FETs, the ZNBG3010 gives 2.2 volts drain whilst the ZNBG3011 gives 2 volts.

These devices are unconditionally stable over the full working temperature with the FETs in place, subject to the inclusion of the recommended gate and drain capacitors. These ensure RF stability and minimal injected noise.

It is possible to use less than the devices full complement of FET bias controls, unused drain and gate connections can be left open circuit without affecting operation of the remaining bias circuits.

In order to protect the external FETs the circuits have been designed to ensure that, under any conditions including power up/down transients, the gate drive from the bias circuits cannot exceed the range -3.5V to 1V. Furthermore if the negative rail experiences a fault condition, such as overload or short circuit, the drain supply to the FETs will shut down avoiding excessive current flow.

The ZNBG3010/11 are available in QSOP16 for the minimum in device size. Device operating temperature is -40 to 70°C to suit a wide range of environmental conditions.

### FEATURES

- Provides bias for GaAs and HEMT FETs
- Drives up to three FETs
- Dynamic FET protection
- Drain current set by external resistor
- Regulated negative rail generator requires only 2 external capacitors
- Choice in drain voltage
- Wide supply voltage range
- Polarisation switch for LNBS
- QSOP surface mount package

### APPLICATIONS

- Satellite receiver LNBS
- Private mobile radio (PMR)
- Cellular telephones

# ZNBG3010 ZNBG3011

**ABSOLUTE MAXIMUM RATINGS**

Supply Voltage	-0.6V to 12V	<b>Power Dissipation (T<sub>amb</sub>= 25°C)</b>	
Supply Current	100mA	QSOP16	500mW
Input Voltage (V <sub>POL</sub> )	25V Continuous		
Drain Current (per FET) (set by R <sub>CAL</sub> )	0 to 15mA		
Operating Temperature	-40 to 70°C		
Storage Temperature	-50 to 85°C		

**ELECTRICAL CHARACTERISTICS TEST CONDITIONS**

 (Unless otherwise stated): T<sub>amb</sub>= 25°C, V<sub>CC</sub>=5V, I<sub>D</sub>=10mA (R<sub>CAL</sub>=33kΩ)

SYMBOL	PARAMETER	CONDITIONS	LIMITS			UNITS
			MIN.	TYP.	MAX.	
V <sub>CC</sub>	Supply Voltage		5		10	V
I <sub>CC</sub>	Supply Current	I <sub>D1</sub> to I <sub>D3</sub> =0 I <sub>D2</sub> and I <sub>D3</sub> =10mA, V <sub>POL</sub> =14V I <sub>D1</sub> and I <sub>D3</sub> =10mA, V <sub>POL</sub> =15.5V			10 30 30	mA mA mA
V <sub>SUB</sub>	Substrate Voltage (Internally generated)	I <sub>SUB</sub> =0 I <sub>SUB</sub> =-200μA	-3.5	-3.0	-2 -2	V V
E <sub>ND</sub> E <sub>NG</sub>	Output Noise Drain Voltage Gate Voltage	C <sub>G</sub> =4.7nF, C <sub>D</sub> =10nF C <sub>G</sub> =4.7nF, C <sub>D</sub> =10nF			0.02 0.005	Vpkipk Vpkipk
f <sub>O</sub>	Oscillator Frequency		200	350	800	kHz

**GATE CHARACTERISTICS**

I <sub>GO</sub>	Output Current Range		-30		2000	μA
		I <sub>Dx</sub> V <sub>POL</sub> I <sub>GOx</sub> (mA)    (V)    (μA)				
V <sub>G10</sub> V <sub>G1L</sub> V <sub>G1H</sub>	Output Voltage Gate 1    Off Low High	I <sub>D1</sub> =0    V <sub>POL</sub> =14    I <sub>GO1</sub> =-10 I <sub>D1</sub> =12   V <sub>POL</sub> =15.5   I <sub>GO1</sub> =-10 I <sub>D1</sub> =8    V <sub>POL</sub> =15.5   I <sub>GO1</sub> =0	-3.5 -3.5 0.4	-2.9 -2.9 0.75	-2.0 -2.0 1.0	V V V
V <sub>G20</sub> V <sub>G2L</sub> V <sub>G2H</sub>	Output Voltage Gate 2    Off Low High	I <sub>D2</sub> =0    V <sub>POL</sub> =15.5   I <sub>GO2</sub> =-10 I <sub>D2</sub> =12   V <sub>POL</sub> =14    I <sub>GO2</sub> =-10 I <sub>D2</sub> =8    V <sub>POL</sub> =14    I <sub>GO2</sub> =0	-3.5 -3.5 0.4	-2.9 -2.9 0.75	-2.0 -2.0 1.0	V V V
V <sub>G3L</sub> V <sub>G3H</sub>	Output Voltage Gate 3    Low High	I <sub>D3</sub> =12                    I <sub>GO3</sub> =-10 I <sub>D3</sub> =8                    I <sub>GO3</sub> =0	-3.5 0.4	-2.9 0.75	-2.0 1.0	V V

<b>ZNBG3010</b> <b>ZNBG3011</b>
------------------------------------

SYMBOL	PARAMETER	CONDITIONS	LIMITS			UNITS
			MIN.	TYP.	MAX.	

**DRAIN CHARACTERISTICS**

$I_D$	Current		8	10	12	mA
$\Delta I_{DV}$ $\Delta I_{DT}$	Current Change with $V_{CC}$ with $T_j$	$V_{CC}=5$ to $10V$ $T_j=-40$ to $+70^\circ C$		0.2 0.05		%/V %/°C
$V_{D1}$	Drain 1 Voltage:High ZNBG3010 ZNBG3011	$I_{D1}=10mA$ , $V_{POL}=15.5V$ $I_{D1}=10mA$ , $V_{POL}=15.5V$	2.0 1.8	2.2 2.0	2.4 2.2	V V
$V_{D2}$	Drain 2 Voltage:High ZNBG3010 ZNBG3011	$I_{D2}=10mA$ , $V_{POL}=14V$ $I_{D2}=10mA$ , $V_{POL}=14V$	2.0 1.8	2.2 2.0	2.4 2.2	V V
$V_{D3}$	Drain 3 Voltage:High ZNBG3010 ZNBG3011	$I_{D3}=10mA$ , $V_{POL}=15.5V$ $I_{D3}=10mA$ , $V_{POL}=15.5V$	2.0 1.8	2.2 2.0	2.4 2.2	V V
$\Delta V_{DV}$ $\Delta V_{DT}$	Voltage Change with $V_{CC}$ with $T_j$	$V_{CC}=5$ to $10V$ $T_j=-40$ to $+70^\circ C$		0.5 50		%/V ppm
$I_{L1}$ $I_{L2}$	Leakage Current Drain 1 Drain 2	$V_{D1}=0.1V$ , $V_{POL}=14V$ $V_{D2}=0.1V$ , $V_{POL}=15.5V$			10 10	$\mu A$ $\mu A$

**POLARITY SWITCH CHARACTERISTICS**

$I_{POL}$	Input Current	$V_{POL}=25V$ (Applied via $R_{POL}=10k\Omega$ )	10	20	40	$\mu A$
$V_{TPOL}$	Threshold Voltage	(Applied via $R_{POL}=10k\Omega$ )	14	14.75	15.5	V
$T_{SPOL}$	Switching Speed				100	$\mu s$

**Notes:**

1. The negative bias voltages specified are generated on-chip using an internal oscillator. Two external capacitors,  $C_{NB}$  and  $C_{SUB}$ , of 47nF are required for this purpose.
2. The characteristics are measured using an external reference resistor  $R_{CAL}$  of value 33k wired from pins  $R_{CAL}$  to ground.
3. Noise voltage is not measured in production.
4. Noise voltage measurement is made with FETs and gate and drain capacitors in place on all outputs.  $C_G$ , 4.7nF, are connected between gate outputs and ground,  $C_D$ , 10nF, are connected between drain outputs and ground.

**ZNBG3010**  
**ZNBG3011**

**TYPICAL CHARACTERISTICS**

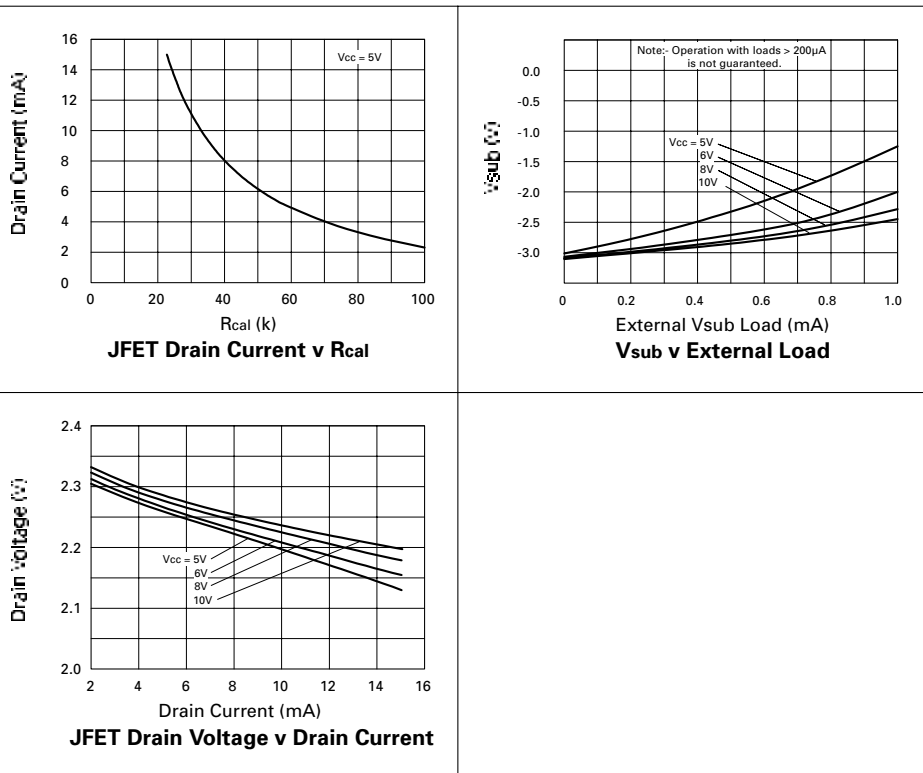

**ZNBG3010  
ZNBG3011**

**FUNCTIONAL DIAGRAM**

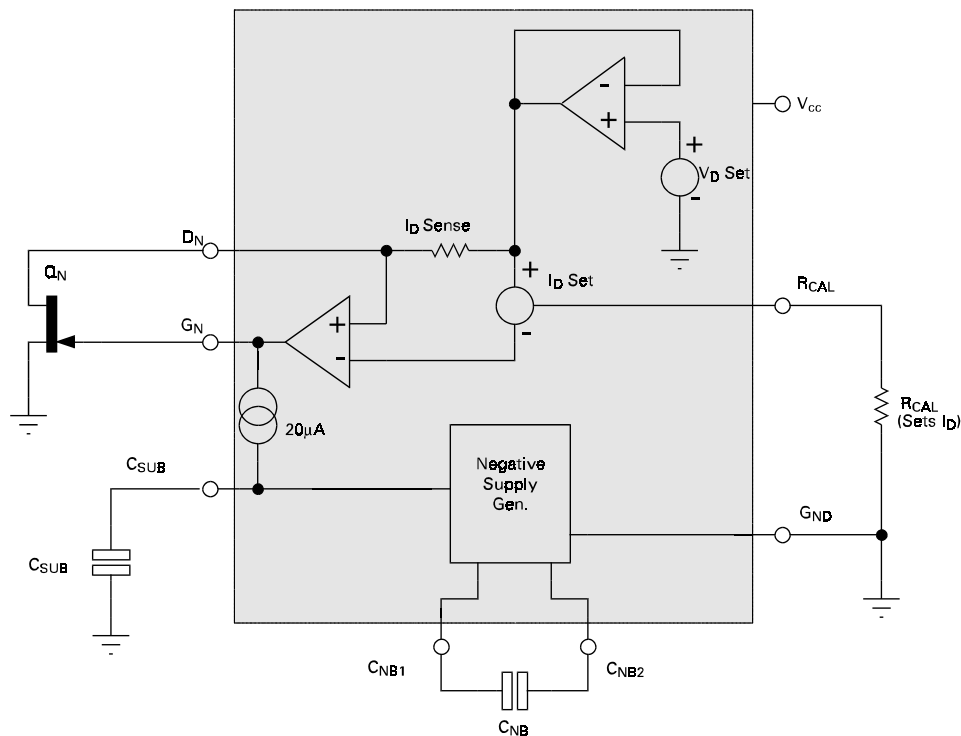

**FUNCTIONAL DESCRIPTION**

The ZNBG devices provide all the bias requirements for external FETs, including the generation of the negative supply required for gate biasing, from the single supply voltage. The diagram above shows a single stage from the ZNBG series. The ZNBG3010/11 contains 3 such stages. The negative rail generator is common to both devices.

The drain voltage of the external FET  $Q_N$  is set by the ZNBG device to its normal operating voltage. This is determined by the on board  $V_D$  Set reference, for the ZNBG3010 this is nominally 2.2 volts whilst the ZNBG3011 provides nominally 2 volts.

The drain current taken by the FET is monitored by the low value resistor  $I_D$  Sense. The amplifier driving the gate of the FET adjusts the gate voltage of  $Q_N$  so that the drain current taken matches the current called for by an external resistor  $R_{CAL}$ .

Since the FET is a depletion mode transistor, it is often necessary to drive its gate negative with respect to ground to obtain the required drain current. To provide this capability powered from a single positive supply, the device includes a low current negative supply generator. This generator uses an internal oscillator and two external capacitors,  $C_{NB}$  and  $C_{SUB}$ .

**ZNBG3010  
ZNBG3011**

**APPLICATIONS CIRCUIT**

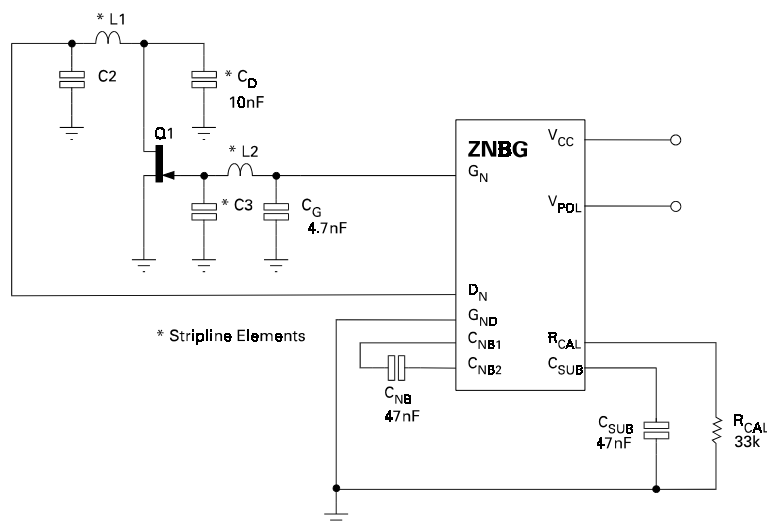

**APPLICATIONS INFORMATION**

The above is a partial application circuit for the ZNBG series showing all external components required for appropriate biasing. The bias circuits are unconditionally stable over the full temperature range with the associated FETs and gate and drain capacitors in circuit.

Capacitors  $C_D$  and  $C_G$  ensure that residual power supply and substrate generator noise is not allowed to affect other external circuits which may be sensitive to RF interference. They also serve to suppress any potential RF feedthrough between stages via the ZNBG device. These capacitors are required for all stages used. Values of 10nF and 4.7nF respectively are recommended however this is design dependent and any value between 1nF and 100nF could be used.

The capacitors  $C_{NB}$  and  $C_{SUB}$  are an integral part of the ZNBGs negative supply generator. The negative bias voltage is generated on-chip using an internal oscillator. The required value of capacitors  $C_{NB}$  and  $C_{SUB}$  is 47nF. This generator produces a low current supply of approximately -3 volts. Although this generator is intended purely to bias the external FETs, it can be used to power other external circuits via the  $C_{SUB}$  pin.

Resistor  $R_{CAL}$  sets the drain current at which all external FETs are operated. If any bias control circuit is not required, its related drain and gate connections may be left open circuit without affecting the operation of the remaining bias circuits.

The ZNBG devices have been designed to protect the external FETs from adverse operating conditions. With a JFET connected to any bias circuit, the gate output voltage of the bias circuit can not exceed the range -3.5V to 1V, under any conditions including powerup and powerdown transients. Should the negative bias generator be shorted or overloaded so that the drain current of the external FETs can no longer be controlled, the drain supply to FETs is shut down to avoid damage to the FETs by excessive drain current.

**ZNBG3010  
ZNBG3011**

The following schematic shows the function of the VPOL input. Only one of the two external FETs numberd Q1 and Q2 are powered at any one time, their selection is controlled by the input VPOL. This input is designed to be wired to the power input of the LNB via a high value (10k) resistor. With the input voltage of the LNB set at or below 14V, FET Q2 will be enabled. With the input voltage at or above 15.5V, FET Q1 will be enabled. The disabled FET has its gate driven low and its drain terminal is switched open circuit. It is permissible to connect the drain pins D1 and D2 together if required by the application circuit. FET number Q3 is always active regardless of the voltage applied to VPOL.

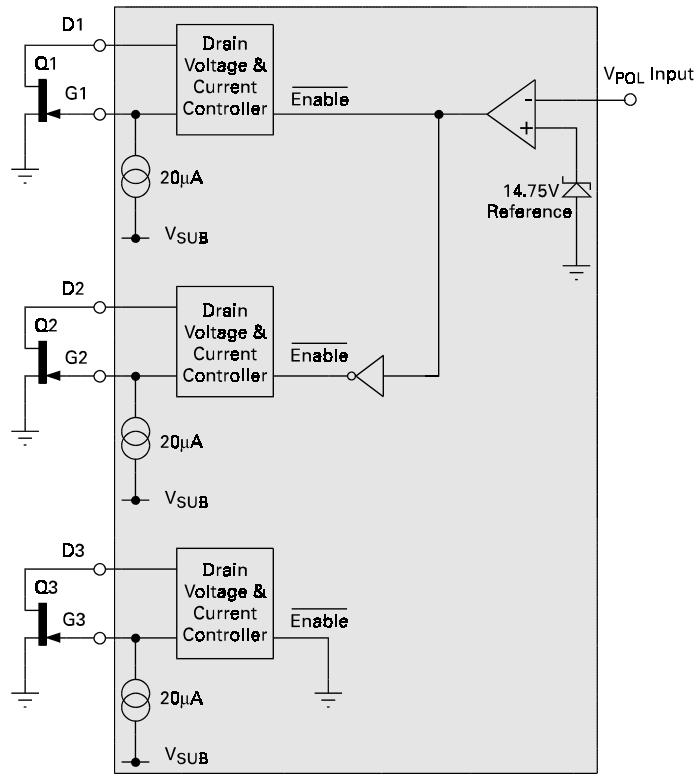

**Control Input Switch Function**

Input Sense	Polarisation	Select
≤14 volts	Vertical	FET Q2
≥ 15.5 volts	Horizontal	FET Q1



**ZNBG3010**  
**ZNBG3011**

**APPLICATIONS INFORMATION (Continued)**

The following block diagram shows the main section of an LNB designed for use with the Astra series of satellites. The ZNBG3010/11 is the core bias and control element of this circuit. The ZNBG provides the negative rail, FET bias control and polarisation switch control, with the minimum of external components. Compared to other discrete component solutions the ZNBG circuit reduces component count and overall size required.

**Single Standard/ Enhanced LNB block diagram.**

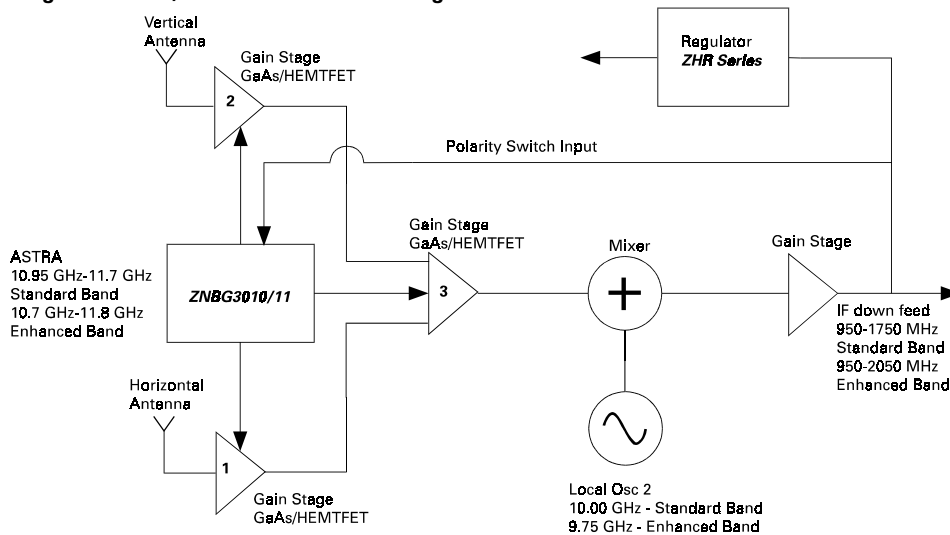

**ZNBG3010**  
**ZNBG3011**

**CONNECTION DIAGRAM**

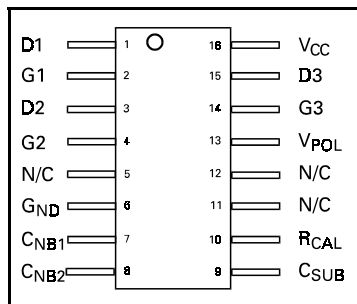

**ORDERING INFORMATION**

Part Number	Package	Part Mark
ZNBG3010Q16	QSOP16	ZNBG3010
ZNBG3011Q16	QSOP16	ZNBG3011

**ZNBG3010**  
**ZNBG3011**

**PACKAGE DIMENSIONS**

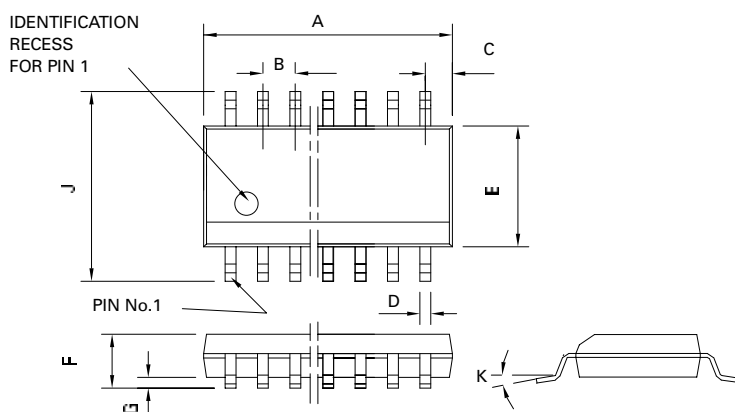

PIN	Millimetres		Inches	
	MIN	MAX	MIN	MAX
A	4.80	4.90	0.189	0.196
B	0.635		0.025 NOM	
C	0.177	0.267	0.007	0.011
D	0.20	0.30	0.008	0.012
E	3.81	3.99	0.15	0.157
F	1.35	1.75	0.053	0.069
G	0.10	0.25	0.004	0.01
J	5.79	6.20	0.228	0.244
K	0°	8°	0°	8°



Zetex plc.  
Fields New Road, Chadderton, Oldham, OL9-8NP, United Kingdom.  
Telephone: (44)161 622 4422 (Sales), (44)161 622 4444 (General Enquiries)  
Fax: (44)161 622 4420

Zetex GmbH  
Streitfeldstraße 19  
D-81673 München  
Germany  
Telefon: (49) 89 45 49 49 0  
Fax: (49) 89 45 49 49 49

Zetex Inc.  
47 Mall Drive, Unit 4  
Commack NY 11725  
USA  
Telephone: (516) 543-7100  
Fax: (516) 864-7630

Zetex (Asia) Ltd.  
3510 Metroplaza, Tower 2  
Hing Fong Road,  
Kwai Fong, Hong Kong  
Telephone: (852) 26100 611  
Fax: (852) 24250 494

These are supported by  
agents and distributors in  
major countries world-wide  
©Zetex plc 1998

Internet: <http://www.zetex.com>

This publication is issued to provide outline information only which (unless agreed by the Company in writing) may not be used, applied or reproduced for any purpose or form part of any order or contract or be regarded as a representation relating to the products or services concerned. The Company reserves the right to alter without notice the specification, design, price or conditions of supply of any product or service.