

Excellent Integrated System Limited

Stocking Distributor

Click to view price, real time Inventory, Delivery & Lifecycle Information:

[STMicroelectronics](#)
[STEVAL-ISB006V1](#)

For any questions, you can email us directly:

sales@integrated-circuit.com



STEVAL-ISB006V1

Dual USB/wall adapter Li-Ion battery charger with gas gauge demonstration board based on the STw4102

Data Brief

Features

- Constant current constant voltage (CCCV) charger
- Dual charging source (main adaptor or USB cable)
- Fast charge current control up to 1A for main adaptor and up to 500 mA for USB
- Internal power device and sense resistor, option for external components for current higher than 1A
- Programmable charge voltage (4.1 V, 4.2 V, 4.3 V, 4.35 V) with 1% accuracy
- Thermal regulation
- Trickle charge mode at low battery voltage
- Main adaptor voltage up to 16 V
- Battery overvoltage protection at 4.7 V
- Gas gauge with 13 bit AD converter
- Battery voltage monitor with 7-12 bit ADC
- I²C interface for device monitoring and control
- Charge status output pin
- Power detection output pin
- Programmable watchdog security timer
- 4.7 V LDO regulator (external MOSFET)

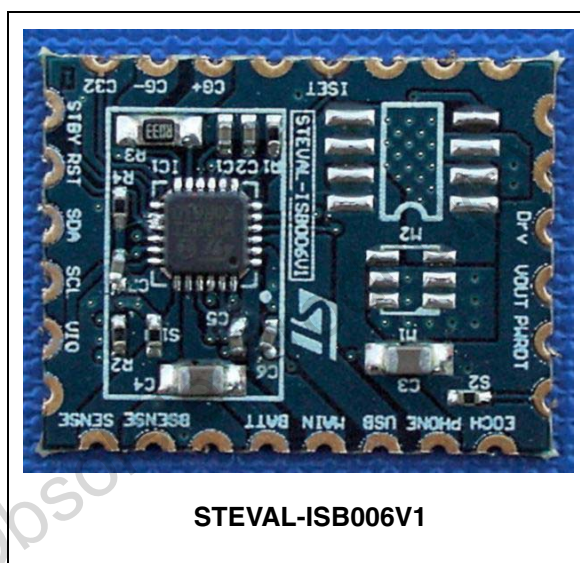

current against the die high power dissipation or high ambient temperature. An end of charge output pin indicates the charge termination when the fast charge current drops below 10% of the programmed current value. The STw4102 contains an accurate gas gauge based on a 13 bit AD converter. External resistor is used between battery and ground to sense a charge/discharge current. With a typical 30 mΩ resistor, current can be up to 2.5 A.

Description

The STEVAL-ISB006V1 demonstration board is based on the STw4102, a stand-alone constant-current constant-voltage (CCCV) linear charger dedicated for Li-Ion battery. This device allows dual charging capability using the main input adaptor up to 1A (wall adaptor, car adaptor) or USB cable up to 500 mA without external component. Upper 1 A charging is possible by adding just one external transistor. This demonstration board offers programmable fast charge current up to 1A with external resistor. A thermal regulation circuitry limits the charge

1 Circuit schematic

Figure 1. Schematic

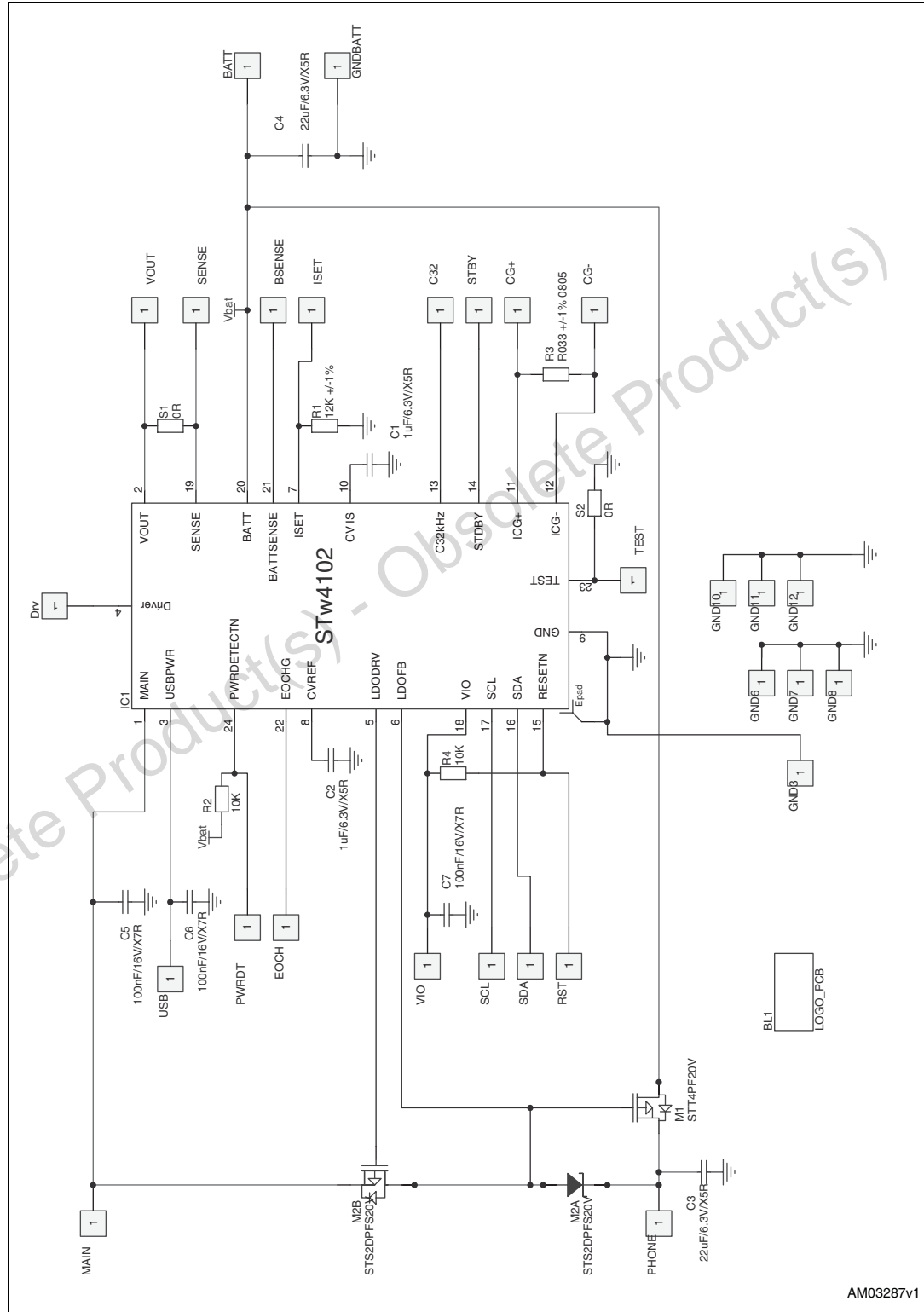

AM03287v1

2 Revision history

Table 1. Document revision history

Date	Revision	Changes
27-Nov-2008	1	Initial release.

Obsolete Product(s) - Obsolete Product(s)

Please Read Carefully:

Information in this document is provided solely in connection with ST products. STMicroelectronics NV and its subsidiaries ("ST") reserve the right to make changes, corrections, modifications or improvements, to this document, and the products and services described herein at any time, without notice.

All ST products are sold pursuant to ST's terms and conditions of sale.

Purchasers are solely responsible for the choice, selection and use of the ST products and services described herein, and ST assumes no liability whatsoever relating to the choice, selection or use of the ST products and services described herein.

No license, express or implied, by estoppel or otherwise, to any intellectual property rights is granted under this document. If any part of this document refers to any third party products or services it shall not be deemed a license grant by ST for the use of such third party products or services, or any intellectual property contained therein or considered as a warranty covering the use in any manner whatsoever of such third party products or services or any intellectual property contained therein.

UNLESS OTHERWISE SET FORTH IN ST'S TERMS AND CONDITIONS OF SALE ST DISCLAIMS ANY EXPRESS OR IMPLIED WARRANTY WITH RESPECT TO THE USE AND/OR SALE OF ST PRODUCTS INCLUDING WITHOUT LIMITATION IMPLIED WARRANTIES OF MERCHANTABILITY, FITNESS FOR A PARTICULAR PURPOSE (AND THEIR EQUIVALENTS UNDER THE LAWS OF ANY JURISDICTION), OR INFRINGEMENT OF ANY PATENT, COPYRIGHT OR OTHER INTELLECTUAL PROPERTY RIGHT.

UNLESS EXPRESSLY APPROVED IN WRITING BY AN AUTHORIZED ST REPRESENTATIVE, ST PRODUCTS ARE NOT RECOMMENDED, AUTHORIZED OR WARRANTED FOR USE IN MILITARY, AIR CRAFT, SPACE, LIFE SAVING, OR LIFE SUSTAINING APPLICATIONS, NOR IN PRODUCTS OR SYSTEMS WHERE FAILURE OR MALFUNCTION MAY RESULT IN PERSONAL INJURY, DEATH, OR SEVERE PROPERTY OR ENVIRONMENTAL DAMAGE. ST PRODUCTS WHICH ARE NOT SPECIFIED AS "AUTOMOTIVE GRADE" MAY ONLY BE USED IN AUTOMOTIVE APPLICATIONS AT USER'S OWN RISK.

Resale of ST products with provisions different from the statements and/or technical features set forth in this document shall immediately void any warranty granted by ST for the ST product or service described herein and shall not create or extend in any manner whatsoever, any liability of ST.

ST and the ST logo are trademarks or registered trademarks of ST in various countries.

Information in this document supersedes and replaces all information previously supplied.

The ST logo is a registered trademark of STMicroelectronics. All other names are the property of their respective owners.

© 2008 STMicroelectronics - All rights reserved

STMicroelectronics group of companies

Australia - Belgium - Brazil - Canada - China - Czech Republic - Finland - France - Germany - Hong Kong - India - Israel - Italy - Japan - Malaysia - Malta - Morocco - Singapore - Spain - Sweden - Switzerland - United Kingdom - United States of America

www.st.com