

Excellent Integrated System Limited

Stocking Distributor

Click to view price, real time Inventory, Delivery & Lifecycle Information:

[Amphenol Commercial Products](#)
[FCC17-E09AD-250](#)

For any questions, you can email us directly:

sales@integrated-circuit.com

REVISIONS			
REV	ECN, ERN NO.	DATE	APPRD.
D	PRODUCT DRAWING	APR29/05	K.L.

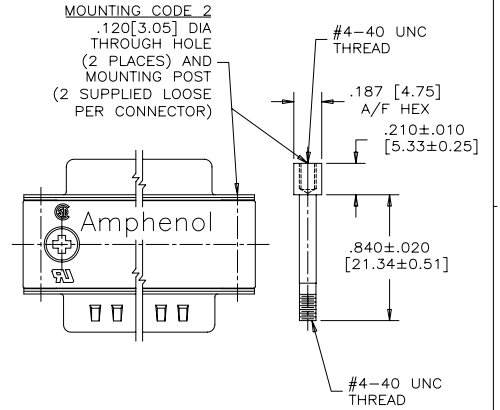
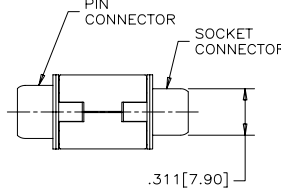
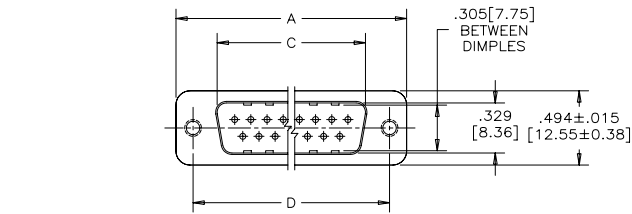
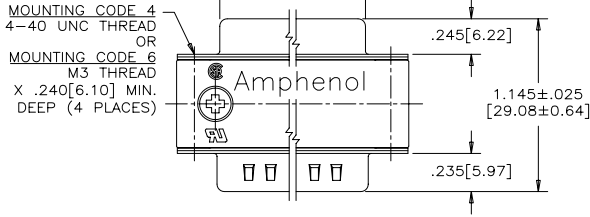

SIZE	A ± .015 [0.38]	B ± .005 [0.13]	C ± .005 [0.13]	D ± .005 [0.13]
E09	1.213 [30.81]	.643 [16.33]	.666 [16.92]	.984 [24.99]
A15	1.541 [39.14]	.971 [24.66]	.994 [25.25]	1.312 [33.32]
B25	2.088 [53.04]	1.511 [38.38]	1.534 [38.96]	1.852 [47.04]
C37	2.729 [69.32]	2.159 [54.84]	2.182 [55.42]	2.500 [63.50]

ORDERING CODE: FCC17 - E09AD - 4 F O G

SERIES _____ CONTACT FINISH/GOLD THICKNESS
NO DIGIT=STANDARD 15 MICRONS [0.38 MICRONS] GOLD
G=50 MICRONS [1.27 MICRONS] GOLD
MODIFIER _____
O=STANDARD

SIZE/NUMBER OF CONTACTS _____
E09, A15, B25, OR C37

CONNECTOR STYLE _____
AD=PIN/SOCKET ADAPTER

MOUNTING _____
2=.120 [3.05] DIA. THROUGH HOLE WITH MOUNTING POST
3=OLD DESIGNATION FOR #4-40 THREAD - USE MOUNTING CODE 4.
4=#4-40 UNC THREAD
6=M3 THREAD

FILTER CAPACITANCE _____
D=50 pF 4=820 pF
B=100 pF 5=1000 pF
O=180 pF 7=1200 pF
F=330 pF E=2200 pF
L=380 pF 9=5600 pF
1=470 pF 8=47000 pF

REFER TO AMPHENOL CATALOGUE FOR FILTER PERFORMANCE CHARACTERISTICS

- NOTES:
- MATERIALS: - SHELLS - TIN PLATED STEEL
- CONTACTS - PHOSPHOR BRONZE PLATED WITH GOLD OVER NICKEL ON THE MATING AREA.
- INSULATOR - ENGINEERING THERMOPLASTIC, FLAMMABILITY RATING UL94V-0, BLACK.
- OUTSIDE SHELLS: ZINC DIECAST, TIN PLATED
 - INSULATION RESISTANCE: 3000 MEGOHMS MINIMUM
 - CURRENT RATING: 5 AMPS MAXIMUM
2 AMPS FILTERING MAXIMUM
 - OPERATING TEMPERATURE: -40°C TO 85°C.
 - TOLERANCE, UNLESS INDICATED OTHERWISE, ±.005 [0.13].

THIS DOCUMENT CONTAINS PROPRIETARY INFORMATION AND SUCH INFORMATION MAY NOT BE DISCLOSED TO OTHERS FOR ANY PURPOSE OR USED FOR MANUFACTURING PURPOSES WITHOUT WRITTEN PERMISSION FROM AMPHENOL CANADA CORP.

MATERIAL	DRAWN I.ESSAJEE DESIGNED K.LAMBIE CHECKED L. E. APPRD. Q. A. APPRD. DWG. APPRD. ENG. REL. NO. REF. EAR C10727 DIMENSIONS ARE IN INCHES [mm]	DATE 99/03/10 99/03/09	Amphenol Canada Corp.
FINISH			TITLE FCC17 SERIES MALE/FEMALE ADAPTER
			DWG. DRAWING NO. C P-FCC17-XXXAD-XXOX
			SCALE 2/1 WT. _____ SURF. _____ SHEET 1 OF 1