

Excellent Integrated System Limited

Stocking Distributor

Click to view price, real time Inventory, Delivery & Lifecycle Information:

[Comchip Technology](#)

[BAV99-G](#)

For any questions, you can email us directly:

sales@integrated-circuit.com

Surface Mount Switching Diode



BAV99 Thru BAW56 Voltage: 70 Volts Current: 215mA



Features

- Fast Switching Speed
- Surface Mount Package Ideally Suited for Automatic Insertion
- For General Purpose Switching Applications
- High Conductance

Mechanical data

Case: SOT-23, Plastic
 Approx. Weight: 0.008 gram

This diodes is also available in other configurations including a dual common cathode with type designation BAV70, a dual common anodes with type designation BAW56 and single chip inside with type Designation BAL99

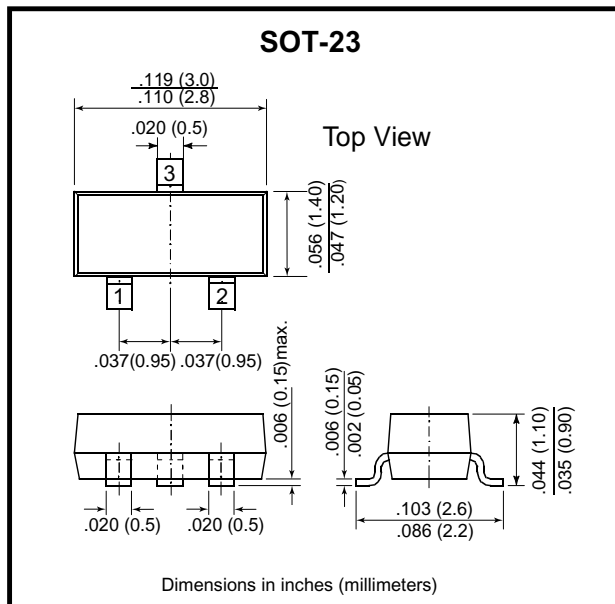
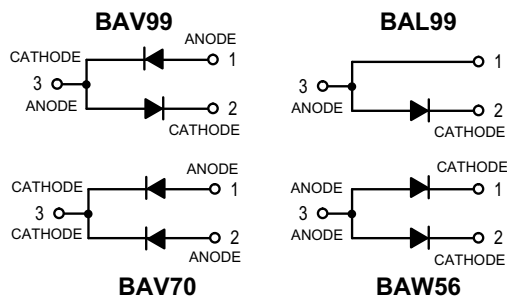

Maximum Ratings

Rating	Symbol	Value	Units
Continuous Reverse Voltage	V_R	70	V_{DC}
Peak Forward Current	I_F	215	mAdc
Peak Forward Surge Current	$I_{FM}(\text{surge})$	500	mAdc

Thermal Characteristics

Characteristic	Symbol	Max	Units
Total Device Dissipation FR-5 Board(1) $T_A = 25^\circ C$	P_D	225	mW
Derate above 25°C		1.8	mW/°C
Thermal Resistance, Junction to Ambient	$R_{\theta JA}$	556	°C/W
Total Device Dissipation Alumina Substrate,(2) $T_A = 25^\circ C$	P_D	300	mW
Derate above 25°C		2.4	mW/°C
Thermal Resistance, Junction to Ambient	$R_{\theta JA}$	417	°C/W
Junction and Storage Temperature	T_J, T_{stg}	-55 to +150	°C

Electrical Characteristics (TA = 25°C unless otherwise noted)

Characteristic (OFF CHARACTERISTICS)	Symbol	Min	Max	Units
Reverse Breakdown Voltage ($I_{BR} = 100 \mu\text{Adc}$)	$V_{(BR)}$	70	-	Vdc
Reverse Voltage Leakage Current $V_R = 25 \text{ Vdc}, T_J = 150^\circ C$	I_R	-	30	μAdc
		$V_R = 70 \text{ Vdc}$	2.5	
		$V_R = 70 \text{ Vdc}, T_J = 150^\circ C$	50	
Diode Capacitance ($V_R = 0, f = 1.0 \text{ MHz}$)	C_D	-	1.5	pF
Forward Voltage $I_F = 1.0 \text{ mAdc}$	VF	-	715	mV
		$I_F = 10 \text{ mAdc}$	855	
		$I_F = 50 \text{ mAdc}$	1000	
		$I_F = 150 \text{ mAdc}$	1250	
Reverse Recovery Time ($I_F = I_R = 10 \text{ mAdc}, I_{R(REC)} = 1.0 \text{ mAdc}$) $R_L = 100\Omega$	T_{rr}	-	6.0	nS

1.FR-5 = 1.0 X 0.75X 0.062 in. 2.Aluminum = 0.4X 0.3X 0.024 in. 99.5% aluminum.

Surface Mount Switching Diode

RATING AND CHARACTERISTIC CURVES (BAV99 Thru BAW56)

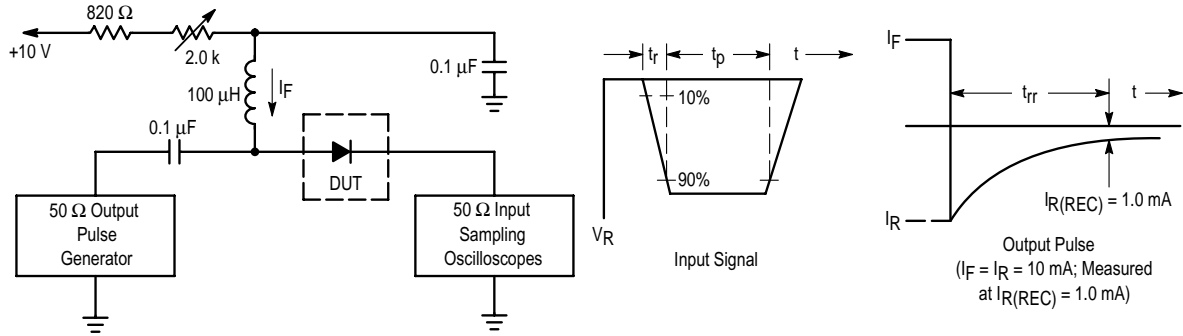

- Notes: 1. A 2.0 kΩ variable resistor adjusted for a Forward Current (I_F) of 10 mA.
 2. Input pulse is adjusted so $I_{R(\text{peak})}$ is equal to 10 mA.
 3. $t_p \gg t_{rr}$

Figure 1. Recovery Time Equivalent Test Circuit

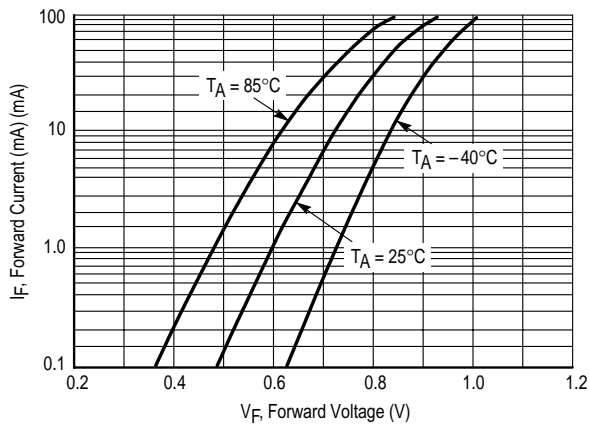

Figure 2. Forward Voltage

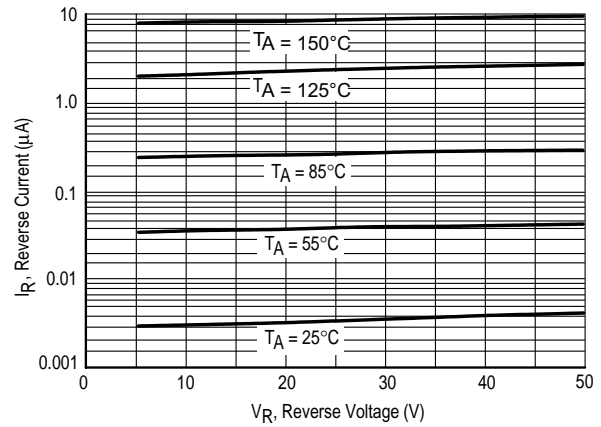

Figure 3. Leakage Current

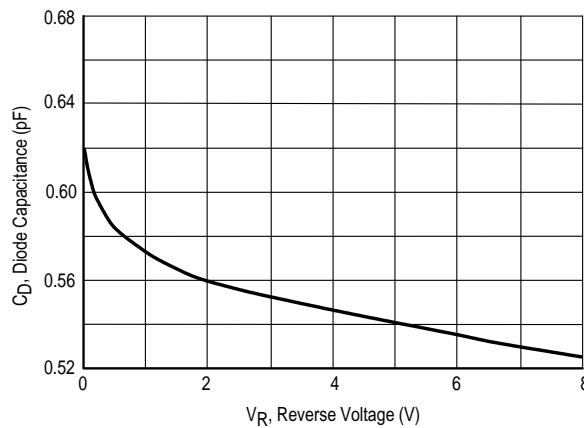

Figure 4. Capacitance