

Excellent Integrated System Limited

Stocking Distributor

Click to view price, real time Inventory, Delivery & Lifecycle Information:

[TT Electronics/Optek Technology](#)
[OV4ZRGBA](#)

For any questions, you can email us directly:

sales@integrated-circuit.com

Optimal IV[®] Star Series Multi-LED Recessed Die Design (RDD)



OV4ZRGBA

- Designed for 4 1-watt chips in recessed cavity with an optical grade 5mm diameter lens
- Exceptional thermal resistance (< 2° C/W junction to heatsink)
- Soldering points or pins provided for electrical connections
- Locating slots for M3 screws

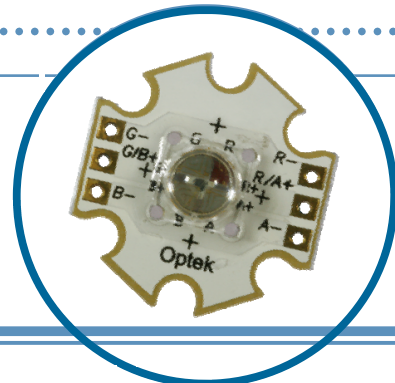

Part Number	Color	Material	Beam Angle	Typ. Dominant Wavelength (nm)	Typical Luminous Flux (lm)		Typical Forward Voltage (V _F)
					350 mA	700mA	350 mA
OV4ZRGBA	Red	AllnGaP	60°	625	35	75	2.5
	Green	InGaN		522	30	45	3.9
	Blue	InGaN		455	5	9	3.6
	Amber	AllnGaP		585	36	55	2.5

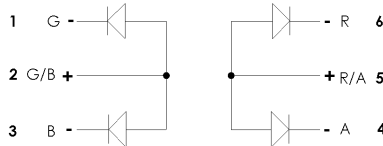
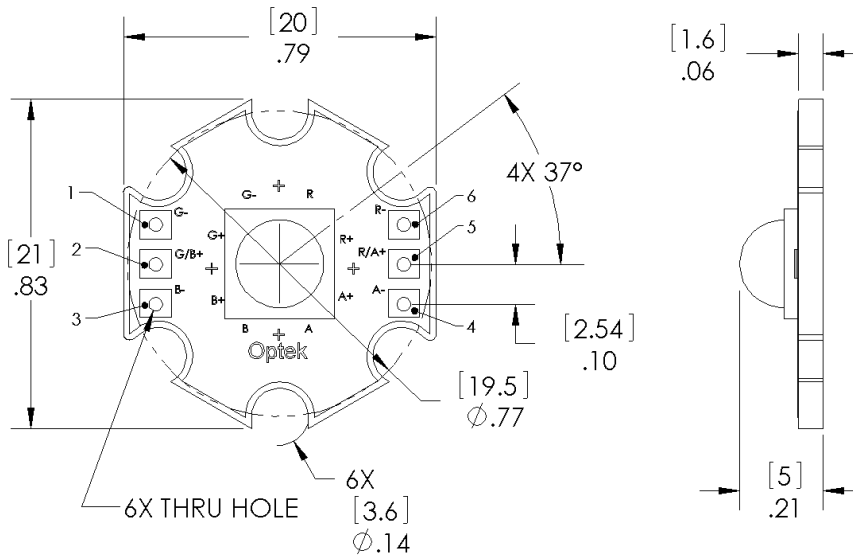

PIN #	DESIGNATOR
1, 6	CATHODE
2, 5	ANODE
3, 4	CATHODE



RoHS
 ATTENTION
 OBSERVE PRECAUTIONS
 ELECTROSTATIC
 SENSITIVE DEVICES

Notes:

- Test conditions: I_F=350mA/700mA; T_J<130°C
- All dimensions are in inches & [millimeters].
- Additional heat sinking required.

DO NOT LOOK DIRECTLY AT LED WITH UNSHIELDED EYES OR DAMAGE TO RETINA MAY OCCUR.

OPTEK reserves the right to make changes at any time in order to improve design and to supply the best product possible.

Optimal IV[®] COS Star Series

OV4ZRGBA



Absolute Maximum Ratings

DC Forward Current /die	700 mA
Peak Pulsed Forward Current ¹	6.0 A
Reverse Voltage	5 V
Maximum Allowable Junction Temperature ²	130° C
Storage and Operating Temperature	-50° ~ +100° C
Electrostatic Discharge Classification (JEDEC-JESD22-A114F)	Class 1C

Notes:

1. Pulse width 1 ms maximum. Duty cycle 1/16.
2. Thermal Resistance junction to Board (T_{jbs}) is <2° C/W

Electrical Characteristics (I_F = 350 mA , T_J = 25° C)

SYMBOL	PARAMETER	TYP	MAX	UNITS
V _F	Forward Voltage (Amber)	2.5	3.0	V
	Forward Voltage (Blue)	3.6	4.0	V
	Forward Voltage (Green)	3.9	4.4	V
	Forward Voltage (Red)	2.5	3.0	V
	V _F -Temperature Co-efficient (Amber & Red)	-6.42	----	mV/°C
	V _F -Temperature Co-efficient (Blue)	-4.81	----	mV/°C
	V _F -Temperature Co-efficient (Green)	-4.95	----	mV/°C

Optical Characteristics (I_F = 350 mA/die , T_J = 25° C)

COLOR	LUMINOUS FLUX (lm) @ I _F = 350mA		DOMINANT WAVELENGTH			SPECTRAL HALF WIDTH	DOMINANT WAVELENGTH TEMPERATURE CO-EFFICIENT
	MIN	TYP	MIN	TYP	MAX		
Amber	15	36	580	585	590	16 nm	0.07 nm/° C
Blue	5	5	450	455	460	20 nm	0.04 nm/° C
Green	30	30	520	522	525	40 nm	0.04 nm/° C
Red	18	35	620	625	630	37 nm	0.05 nm/° C

Packaging: 10 Optimal IV[®] stars per tube

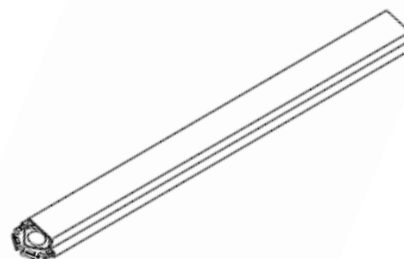
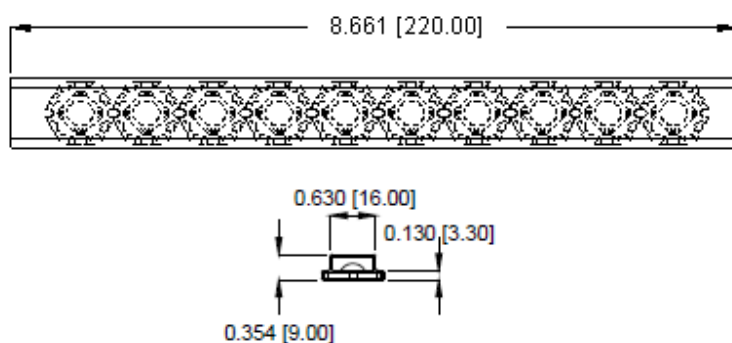

OPTEK reserves the right to make changes at any time in order to improve design and to supply the best product possible.

Optimal IV[®] COS Star Series OV4ZRGBA



Relative Spectral Responses @ 350mA / die

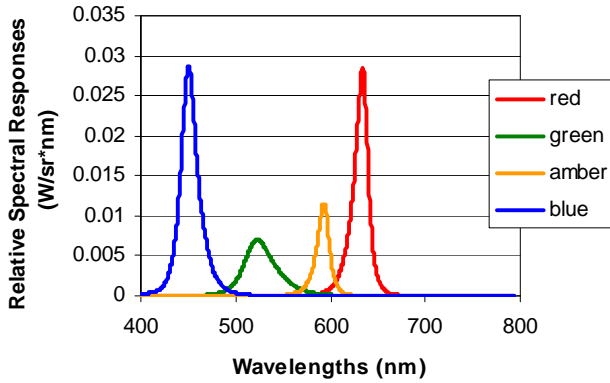

Spectral Responses for CRI 90
(varied RGB I_F Drives)

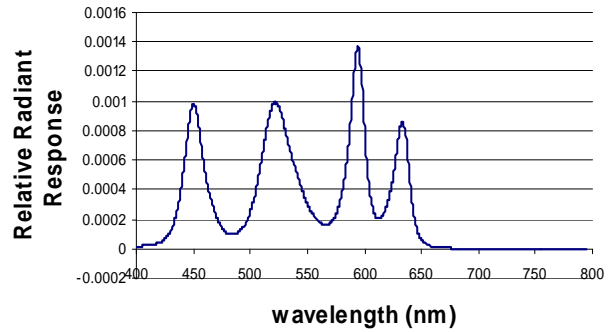

Dominant Wavelength vs IF

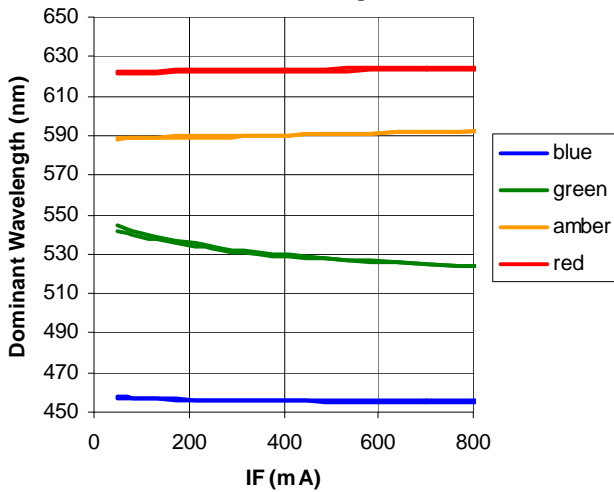

Total Luminous Flux vs IF

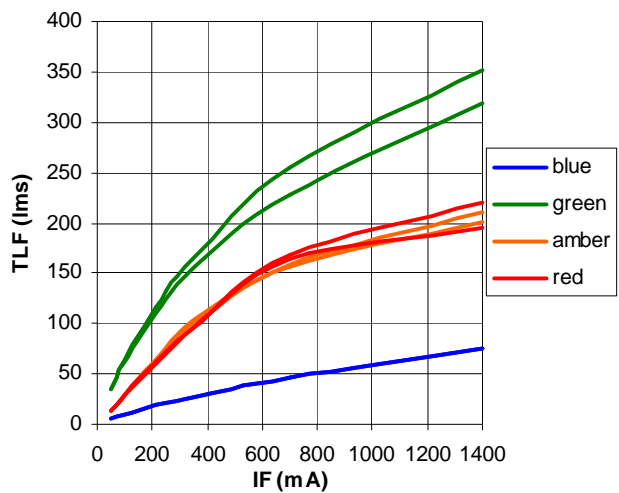

IF vs VF

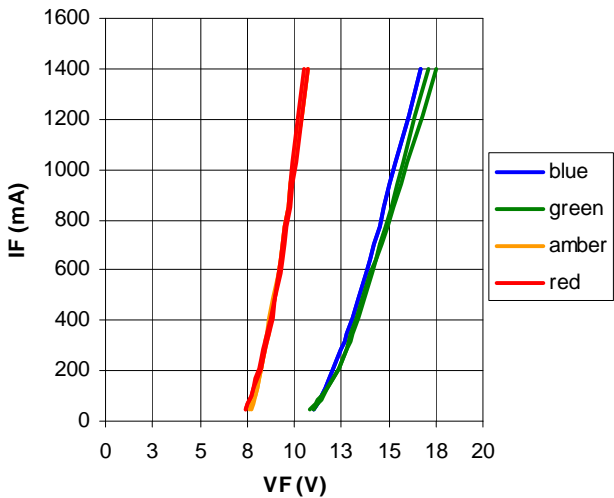

Derating Curve/die

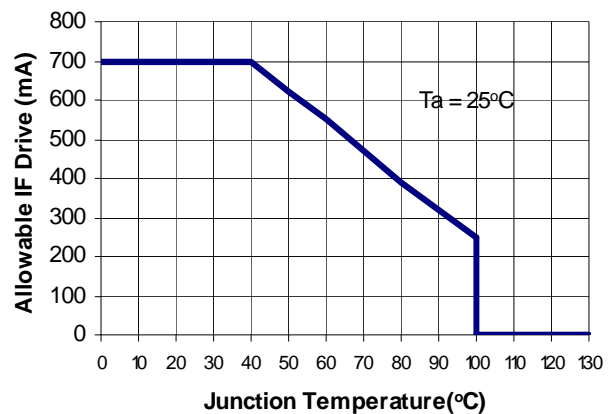

OPTEK reserves the right to make changes at any time in order to improve design and to supply the best product possible.