

## **Excellent Integrated System Limited**

Stocking Distributor

Click to view price, real time Inventory, Delivery & Lifecycle Information:

[APM Hexseal](#)  
[HE1070](#)

For any questions, you can email us directly:

[sales@integrated-circuit.com](mailto:sales@integrated-circuit.com)

**SPECIFICATION**

**Material:** Boot: APM RUBGLAS™ (transparent silicone rubber), conforms to A-A-59588, Class III Grade 50, Frame: steel, zinc plated with chromate finish. Screw: SEELSKREW® (self-sealing screws), stainless steel with silicone rubber O-ring.  
**Temperature Range:** HEXSEAL: -94°F to +400°F  
**Pressure Range:** Dust tight and splashproof.  
**Operational Life:** 10,000 actuations (minimum).  
**Shelf Life:** Excess of 25 years.  
**Resistant to:** Salt spray, sunlight, ozone, weather, corona and most acids.

**Notes:**  
 1. Mounting screws are supplied in lengths shown unless otherwise specified.  
 2. New sizes and types of RUBGLAS-SEELS® are being added regularly. Please request other types and styles as required.  
**Agency Recognition:** Front Panel mounted Circuit Breaker Boots are UL-listed to UL Std. 50, types 1,2,3,12,12K and 13. Back-of-Panel mounted Circuit Breaker boots are UL-listed to UL Std. 50, type 1, Also meet CSA standards.

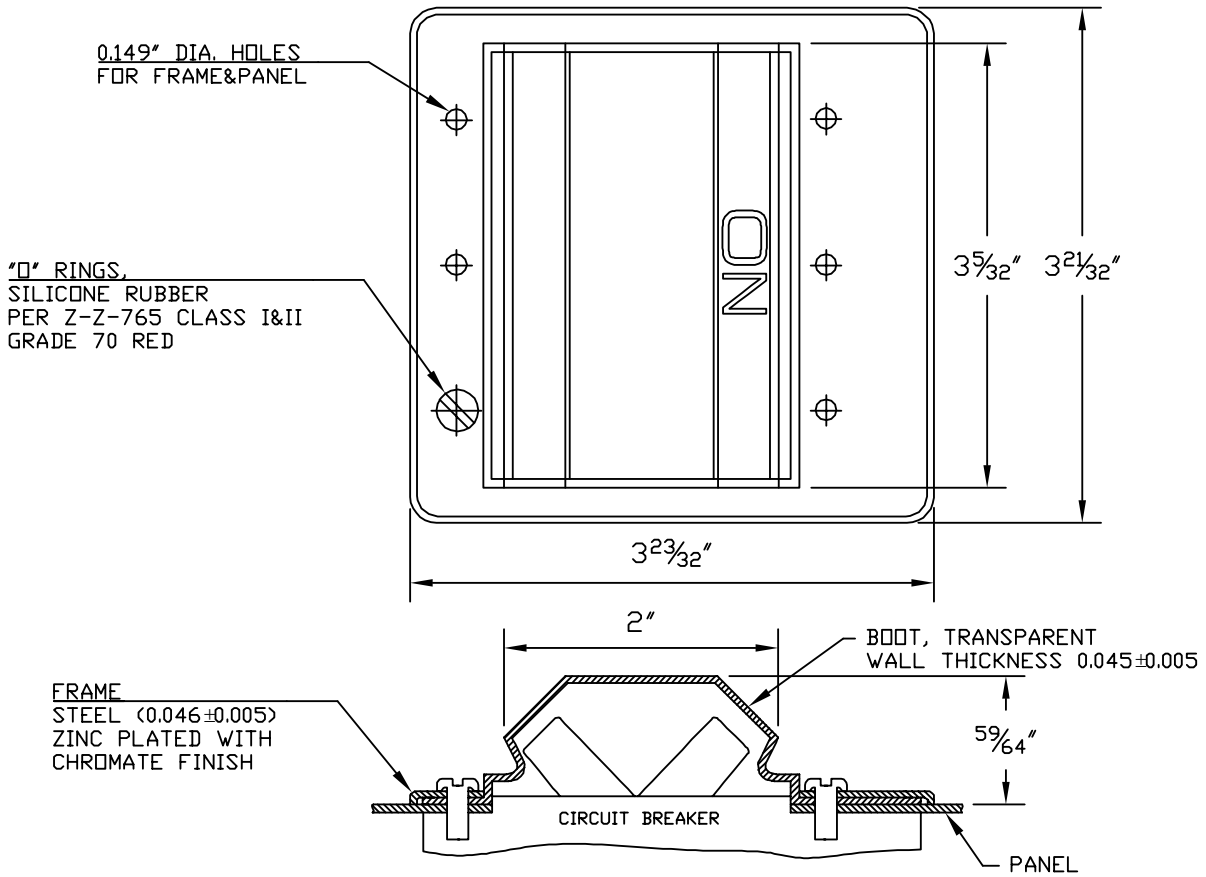

**NOTES:**

ASSEMBLY CONSISTS OF 1 BOOT, MAT'L APM RUBGLAS®, 1 FRAME MAT'L C.R.S. ZINC PLATED WITH CHROMATE FINISH, & #6-32 APM SEELSKREWS® LENGTH = 3/8 UNLESS OTHERWISE SPECIFIED

TOLERANCES: UNLESS OTHERWISE NOTED ±1/32

J	RUBBER and FRAME MAT'L CHANGED, WALL THICKNESS TOL. 0.010 CHANGED TO 0.005, HEIGHT DIM. 26/64" CHANGED TO 59/64", DELETED TO "DESIGN TO MEET MIL-5423/14-03" and DELETED TO SEELSKREW INFORMATION	S. GOK	05.05.09
I	CAD COMPUTER GENERATED		11.13.02
H	REDRAWN	R.C.	09.18.77
REV.	DESCRIPTION		DATE
	CIRCUIT BREAKER BOOT, TOGGLE, WIDE ANGLE, TRANSPARENT (3 POLES)	ENG.	M.M.
		DWN.	J.P.
		CHKD.	
	APM-HEXSEAL CORPORATION	SCALE	HE-1070
		3/4 : 1	
		DWG. NO.	

THIS DRAWING COVERS PROPRIETARY ITEM AND IS THE PROPERTY OF THE APM-HEXSEAL CORPORATION. THIS DRAWING IS NOT TO BE COPIED OR USED WITHOUT THE WRITTEN APPROVAL OF AN OFFICER OF THE APM-HEXSEAL CORPORATION.