

Excellent Integrated System Limited

Stocking Distributor

Click to view price, real time Inventory, Delivery & Lifecycle Information:

[Powerex Inc.](#)
[CE420860](#)

For any questions, you can email us directly:
sales@integrated-circuit.com



CE420860

Powerex, Inc., 200 Hillis Street, Youngwood, Pennsylvania 15697-1800 (724) 925-7272

Three-Phase SCR/Diode Bridge Modules
60 Amperes/800 Volts

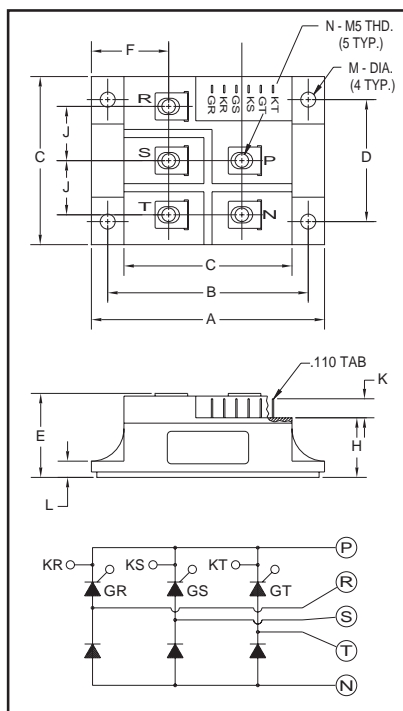

Outline Drawing

Dimension	Inches	Millimeters
A	3.386	86
B	2.913±0.012	74±0.3
C	2.441	62
D	1.772±0.008	45±0.2
E	1.220	31
F	1.122	28.5
G	1.063	27
H	0.866	22
J	0.787	20
K	0.276	7
L	0.236	6
M	0.217±0.008 Dia.	5.5±0.2 Dia.
N	M5 Metric	M5

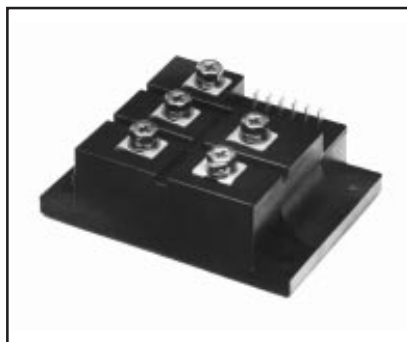

CE420860
Three-Phase SCR/Diode
Bridge Modules
 60 Amperes/800 Volts

Description:

Powerex Three-Phase SCR/Diode Bridge Modules are designed for use in applications requiring variable DC Voltage control from AC mains. The modules are isolated for easy mounting with other components on common heatsinks.

Features:

- Isolated Mounting
- Glass Passivated Chips
- di/dt = 500V/μsec
- Metal Baseplate
- Low Thermal Impedance
- Quick Connect Signal Terminals

Applications:

- Battery Supplies
- AC and DC Motor Control
- Furnace Control

Ordering Information:

Select the complete eight digit module part number you desire from the table below.

Example: CE420860 is a 800 Volt, 60 Ampere Three-Phase SCR/Diode Bridge Module.

Type	Voltage Volts (x100)	Current Rating Amperes (60)
CE42	08	60



Powerex, Inc., 200 Hillis Street, Youngwood, Pennsylvania 15697-1800 (724) 925-7272

CE420860
Three-Phase SCR/Diode Bridge Modules
 60 Amperes/800 Volts

Absolute Maximum Ratings

Characteristics	Symbol	CE420860	Units
Peak Forward Blocking Voltage	V_{DRM}	800	Volts
Transient Peak Forward Blocking Voltage (Non-Repetitive), $t < 5ms$	V_{DSM}	960	Volts
DC Forward Blocking Voltage	$V_{D(DC)}$	640	Volts
Peak Reverse Blocking Voltage	V_{RRM}	800	Volts
Transient Peak Reverse Blocking Voltage (Non-Repetitive), $t < 5ms$	V_{RSM}	960	Volts
DC Reverse Blocking Voltage	$V_{R(DC)}$	640	Volts
DC Output Current, $T_C = 80^\circ C$	I_O	60	Amperes
Peak One-Cycle Surge (Non-Repetitive) On-State Current (60Hz)	I_{TSM}, I_{FSM}	500	Amperes
Peak One-Cycle Surge (Non-Repetitive) On-State Current (50Hz)	I_{TSM}, I_{FSM}	460	Amperes
I^2t (for Fusing), 8.3 milliseconds	I^2t	1050	A ² sec
Critical Rate-of-Rise of On-State Current*	di/dt	100	Amperes/ μs
Peak Gate Power Dissipation	P_{GM}	5.0	Watts
Average Gate Power Dissipation	$P_{G(AV)}$	0.5	Watts
Peak Forward Gate Voltage	V_{GFM}	10	Volts
Peak Reverse Gate Voltage	V_{GRM}	5.0	Volts
Peak Forward Gate Current	I_{GFM}	2.0	Amperes
Storage Temperature	T_{STG}	-40 to 125	$^\circ C$
Operating Temperature	T_j	-40 to 125	$^\circ C$
Maximum Mounting Torque M5 Mounting Screw	—	17	in.-lb.
Maximum Mounting Torque M5 Terminal Screw	—	17	in.-lb.
Module Weight (Typical)	—	310	Grams
V Isolation	V_{RMS}	2000	Volts

* $T_j = 125^\circ C, I_G = 0.5A, V_D = 1/2 V_{DRM}$



Powerex, Inc., 200 Hillis Street, Youngwood, Pennsylvania 15697-1800 (724) 925-7272

CE420860
Three-Phase SCR/Diode Bridge Modules
 60 Amperes/800 Volts

Electrical and Thermal Characteristics, $T_j = 25^\circ\text{C}$ unless otherwise specified

Characteristics	Symbol	Test Conditions	CE420860	Units
Blocking State Maximums				
Forward Leakage Current, Peak	I_{DRM}	$T_j = 125^\circ\text{C}$, $V_{\text{DRM}} = \text{Rated}$	4.0	mA
Reverse Leakage Current, Peak	I_{RRM}	$T_j = 125^\circ\text{C}$, $V_{\text{RRM}} = \text{Rated}$	4.0	mA
Conducting State Maximums				
Peak On-State Voltage	V_{FM}	$I_{\text{FM}} = 75\text{A}$, $I_{\text{TM}} = 75\text{A}$	1.4	Volts
Switching Minimums				
Critical Rate-of-Rise of Off-State Voltage	dv/dt	$T_j = 125^\circ\text{C}$, $V_{\text{D}} = 2/3 V_{\text{DRM}}$	500	Volts/ μs
Thermal Maximums				
Thermal Resistance, Junction-to-Case	$R_{\theta(\text{J-C})}$	Per Module	1.5	$^\circ\text{C/Watt}$
Thermal Resistance, Case-to-Sink (Lubricated)	$R_{\theta(\text{C-S})}$	Per Module	0.06	$^\circ\text{C/Watt}$
Gate Parameters Maximums				
Gate Current-to-Trigger	I_{GT}	$V_{\text{D}} = 6\text{V}$, $R_{\text{L}} = 2\Omega$	50	mA
Gate Voltage-to-Trigger	V_{GT}	$V_{\text{D}} = 6\text{V}$, $R_{\text{L}} = 2\Omega$	2.0	Volts
Non-Triggering Gate Voltage	V_{GDM}	$T_j = 125^\circ\text{C}$, $V_{\text{D}} = 1/2 V_{\text{DRM}}$	0.25	Volts



Powerex, Inc., 200 Hillis Street, Youngwood, Pennsylvania 15697-1800 (724) 925-7272

CE420860
Three-Phase SCR/Diode Bridge Modules
 60 Amperes/800 Volts

