

Excellent Integrated System Limited

Stocking Distributor

Click to view price, real time Inventory, Delivery & Lifecycle Information:

[Intersil](#)
[ISL85001EVAL1Z](#)

For any questions, you can email us directly:
sales@integrated-circuit.com

Description

The ISL85001EVAL1Z REV A kit is intended for use by individuals with requirements for Point-of-Load applications sourcing from 4.5V to 25V. The ISL85001EVAL1Z evaluation board is used to demonstrate the performance of the ISL85001 standard buck regulator.

The ISL85001 is offered in a 4mmx3mm 12 Ld DFN package with 1mm maximum height. The complete converter occupies less than 0.425in² area.

Features

- Standard Buck Controller with Integrated Switching Power MOSFET
- Integrated Boot Diode
- Input Voltage Range
 - Fixed 5V ±10%
 - Variable 5.5V to 25V
- PWM Output Voltage Adjustable from 0.6V to 19V with Continuous Output Current up to 1A
- Voltage Mode Control with Voltage Feed-Forward
- Fixed 500kHz Switching Frequency
- Externally Adjustable Soft-Start Time
- Output Undervoltage Protection
- Enable Inputs
- PGOOD Output
- Overcurrent Protection
- Thermal Overload Protection
- Internal 5V LDO regulator

Applications

- General Purpose
- WLAN Cards-PCMCIA, Cardbus32, MiniPCI Cards-Compact Flash Cards
- Hand-Held Instruments
- LCD Panel
- Set-top Box

What's Inside

The Evaluation Board Kit contains the following materials:

- The ISL85001 EVAL REV A board
- The ISL85001 datasheet
- This EVAL KIT document

Recommended Equipment

The Following Materials are Recommended to Perform Testing:

- 0V to 25V Power Supply with at Least 5A Source Current Capability, Battery, Notebook AC Adapter
- One Electronic Load Capable of Sinking Current up to 5A
- Digital Multimeters (DMMs)
- 100MHz Quad-Trace Oscilloscope
- Signal Generator

Quick Setup Guide

1. Ensure that the circuit is correctly connected to the supply and loads prior to applying any power.
2. Connect the bias supply to VIN, the plus terminal to TP1 (VIN) and the negative return to TP2 (GND).
3. Verify that SW1 is on ENABLE.
4. Turn on the power supply.
5. Verify the PG is on and the output voltage is 2.5V for VOUT(TP3).

Evaluating the Other Output Voltage

The ISL85001EVAL kit outputs are preset to 2.5V; however, it can be programmed using resistor dividers using Equation 1:

$$R_2 = \frac{R_1 \cdot 0.6V}{V_{OUT} - 0.6V} \quad (\text{EQ. 1})$$

The output voltage programming resistor R₂ will depend on the feedback resistor R₁, as referred to in Figure 1. The value of R₁ is typically between 1kΩ and 10kΩ. If the output voltage desired is 0.6V, then R₂ is left opened.

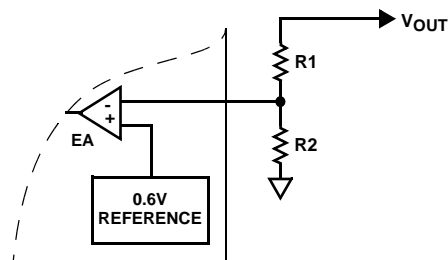

FIGURE 1. EXTERNAL RESISTOR DIVIDER

TABLE 1. SWITCH 1 SETTINGS

SW1	ENABLE	OPERATING MODE
1	SW1	Enable or disable the buck controller

Application Note 1443

ISL85001EVAL1Z Schematic

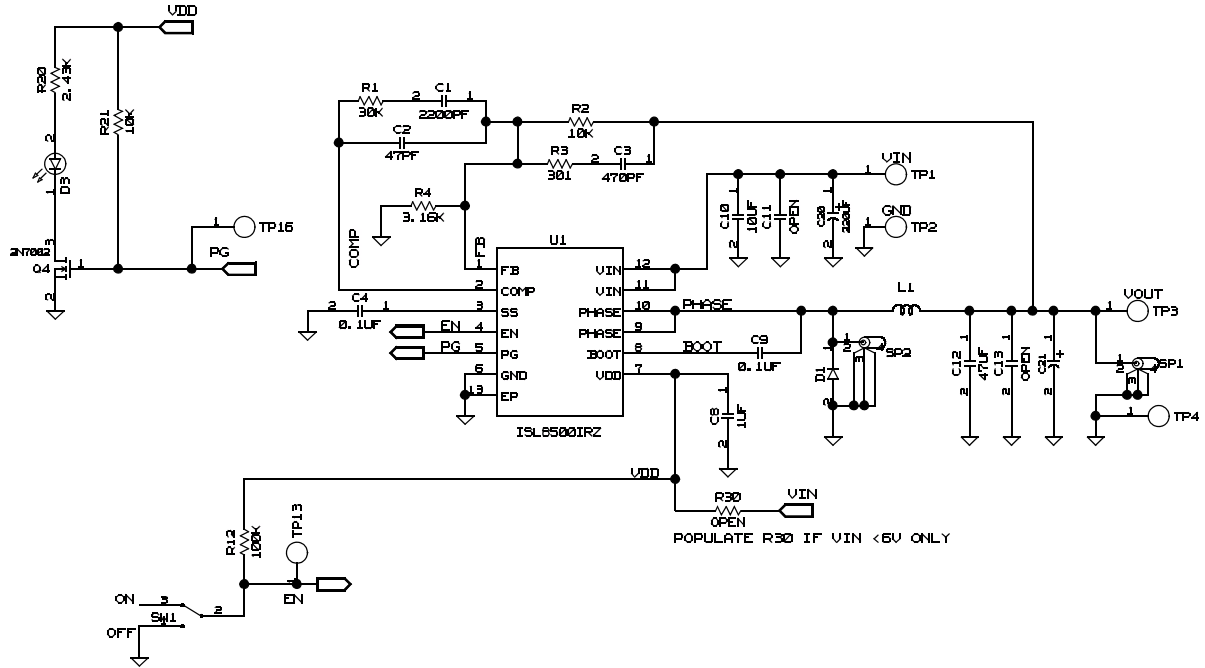

Application Note 1443

ISL85001EVAL1Z Bill of Materials

PART NUMBER	QTY	UNITS	REFERENCE DESIGNATOR	DESCRIPTION	MFR	MANUFACTURER PART
ISL85001EVAL1ZREVA PCB	1	ea	See Label-Rename Board	PWB-PCB, ISL85001EVAL1Z, REVA, ROHS	TITAN	ISL85001EVAL1ZREVA PCB
C1608X7R1H104K-T	1	ea	C9	CAPACITOR, SMD, 0603, 0.10µF, 50V, 10%, X7R	TDK	C1608X7R1H104K
H1044-00104-16V10-T	1	ea	C4	CAP, SMD, 0402, 0.1µF, 16V, 10%, X7R, ROHS	MURATA	GRM36X7R104K016AD
H1044-00222-50V10-T	1	ea	C1	CAP, SMD, 0402, 2200pF, 50V, 10%, X7R, ROHS	PANASONIC	ECJ-0EB1H222K
H1044-00470-50V5-T	1	ea	C2	CAP, SMD, 0402, 47pF, 50V, 5%, NPO, ROHS	MURATA	GRM36COG470J050AQ
H1044-00471-50V10-T	1	ea	C3	CAP, SMD, 0402, 470pF, 50V, 10%, X7R, ROHS	PANASONIC	ECJ-0EB1H471K
H1045-00105-6R3V10-T	1	ea	C8	CAP, SMD, 0603, 1µF, 6.3V, 10%, X5R, ROHS	PANASONIC	ECJ1VB0J105K
H1065-00106-25V10-T	1	ea	C10	CAP, SMD, 1206, 10µF, 25V, 10%, X5R, ROHS	VENKEL	C1206X5R250-106KNE
H1082-00476-16V20-T	1	ea	C12	CAP, SMD, 1210, 47µF, 16V, 20%, X5R, ROHS	TDK	C3225X5R1C476M
IHLP2525CZER220M11	1	ea	L1	COIL-PWR INDUCTOR, SMD, 6.9x6.5, 22µH, 20%, 7A, ROHS	VISHAY	IHLP2525CZER220M11
131-4353-00	2	ea	SP1, SP2	CONN-SCOPE PROBE TEST PT, COMPACT, PCB MNT, ROHS	TEKTRONIX	131-4353-00
1514-2	4	ea	TP1 to TP4	CONN-TURRET, TERMINAL POST, TH, ROHS	KEYSTONE	1514-2
5002	2	ea	TP13, TP16	CONN-MINI TEST POINT, VERTICAL, WHITE, ROHS	KEYSTONE	5002
B340LB-13-F-T	1	ea	D1	DIODE-SCHOTTKY, SMD, SMB, 2P, 40V, 3A LOW VF, ROHS	DIODES INC.	B340LB-13-F
LTST-C170CKT	1	ea	D3	LED-GaAs RED, SMD, 2x1.25mm, 100mW, 40mA, 10mcd, ROHS	LITEON/VISHAY	LTST-C170CKT
ISL85001IRZ	1	ea	U1	IC-2A BUCK REGULATOR, 12P, DFN, 4x3, ROHS	INTERSIL	ISL85001IRZ
2N7002-7-F-T	1	ea	Q4	TRANSISTOR, N-CHANNEL, 3LD, SOT-23, 60V, 115mA, ROHS	DIODES, INC.	2N7002-7-F
H2510-01002-1/16W1-T	1	ea	R2	RES, SMD, 0402, 10k, 1/16W, 1%, TF, ROHS	PANASONIC	ERJ-2RKF1002
H2510-01003-1/16W1-T	1	ea	R12	RES, SMD, 0402, 100k, 1/16W, 1%, TF, ROHS	PANASONIC	ERJ2RKF1003
H2510-03002-1/16W1-T	1	ea	R1	RES, SMD, 0402, 30k, 1/16W, 1%, TF, ROHS	YAGEO	RC0402FR-0730KL
H2510-03010-1/16W1-T	1	ea	R3	RES, SMD, 0402, 301Ω, 1/16W, 1%, TF, ROHS	PANASONIC	ERJ-2RKF3010X

Application Note 1443

ISL85001EVAL1Z Bill of Materials (Continued)

PART NUMBER	QTY	UNITS	REFERENCE DESIGNATOR	DESCRIPTION	MFR	MANUFACTURER PART
H2510-03161-1/16W1-T	1	ea	R4	RES, SMD, 0402, 3.16k, 1/16W, 1%, TF, ROHS	VENKEL	CR0402-16W-3161FT
H2511-01002-1/10W1-T	1	ea	R21	RES, SMD, 0603, 10k, 1/10W, 1%, TF, ROHS	KOA	RK73H1JT1002F
H2511-02431-1/10W1-T	1	ea	R20	RES, SMD, 0603, 2.43k, 1/10W, 1%, TF, ROHS	VENKEL	CR0603-10W-2431FT
H2511-DNP	0	ea	R30	RES, SMD, 0603, DNP-PLACE HOLDER, ROHS		
GT11MSCBE-T	1	ea	SW1	SWITCH-TOGGLE, SMD, ULTRAMINI, 1P, SPST MINI	C&K COMPONENTS	GT11MSCKE
4-40x1/2-SCREW	4	ea	Four corners	SCREW, 4-40x1/2in, PAN, NYLON, PHILLIPS, ROHS		
4-40x3/4-STANDOFF	4	ea	Four corners	STANDOFF, 4-40x3/4in, F/F, HEX, NYLON	KEYSTONE	1902D
5x8-STATIC-BAG	1	ea	Place assy in bag.	BAG, STATIC, 5x8, ZIP LOC	INTERSIL	212403-013
DNP	0	ea	C11, C13, C20, C21	DO NOT POPULATE OR PURCHASE		
LABEL-RENAME BOARD	1	ea	RENAME PCB TO: ISL85001EVAL1Z	LABEL, TO RENAME BRD		
LABEL-SERIAL NUMBER	1	ea		LABEL, FOR SERIAL NUMBER AND BOM REV #		

Application Note 1443

ISL85001EVAL1Z Board Layout

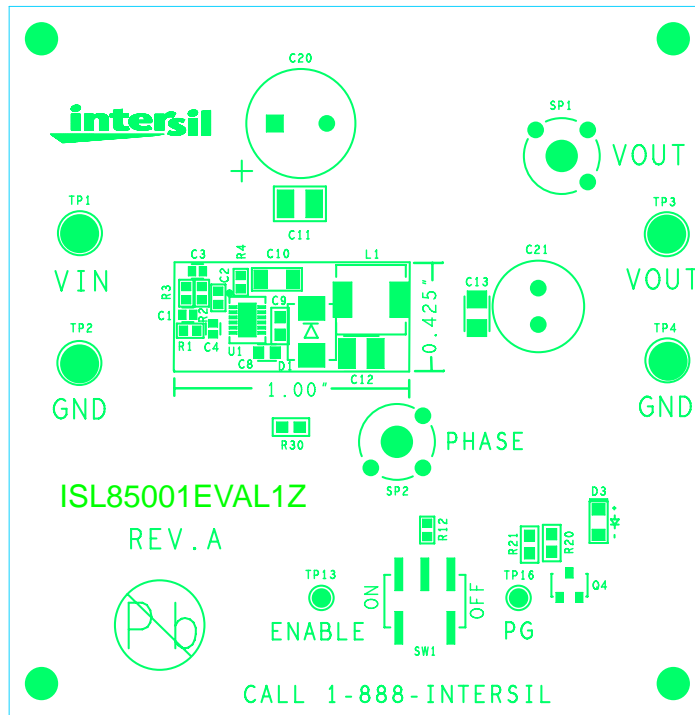

FIGURE 2. TOP COMPONENTS

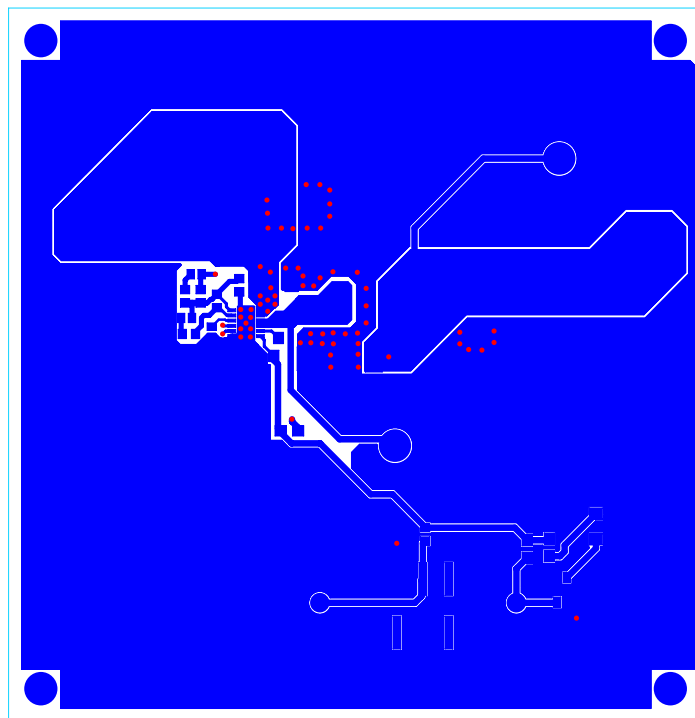

FIGURE 3. TOP LAYER ETCH

Application Note 1443

ISL85001EVAL1Z Board Layout (Continued)

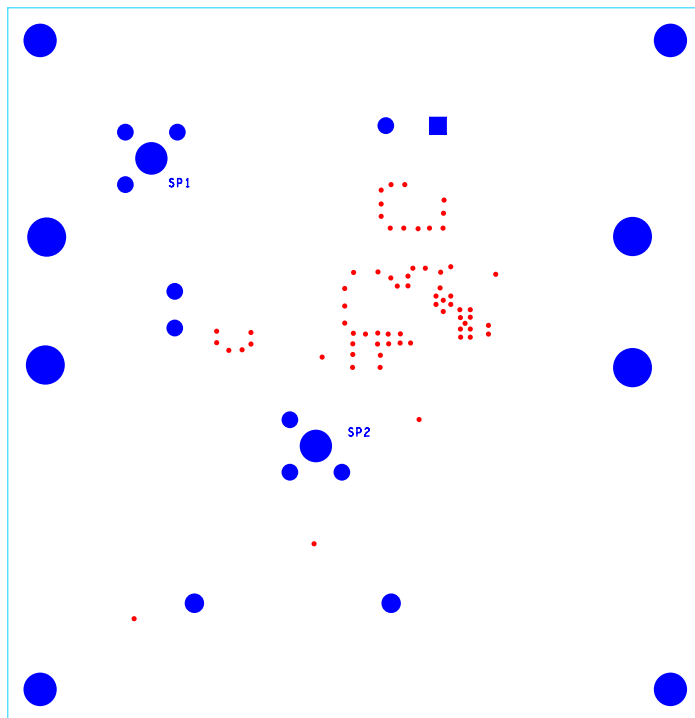

FIGURE 4. BOTTOM LAYER COMPONENTS (MIRRORED)

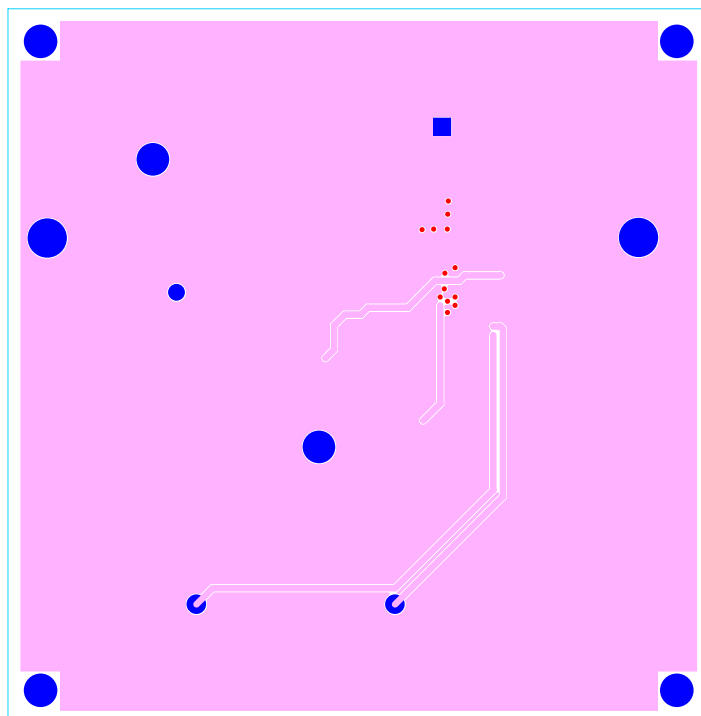

FIGURE 5. BOTTOM LAYER ETCH (MIRRORED)

Intersil Corporation reserves the right to make changes in circuit design, software and/or specifications at any time without notice. Accordingly, the reader is cautioned to verify that the Application Note or Technical Brief is current before proceeding.

For information regarding Intersil Corporation and its products, see www.intersil.com