

Excellent Integrated System Limited

Stocking Distributor

Click to view price, real time Inventory, Delivery & Lifecycle Information:

[TE Connectivity AMP Connectors](#)
[768350-1](#)

For any questions, you can email us directly:

sales@integrated-circuit.com



**AMP* Connector-Specific Kit 768350-1
 for AMP-LATCH* 50-Position HDF Connectors**

PROPER USE GUIDELINES

Cumulative Trauma Disorders can result from the prolonged use of manually powered hand tools. AMP hand tools are intended for occasional use and low volume applications. AMP offers a wide selection of powered application equipment for extended-use, production operations.

CONNECTOR-SPECIFIC KIT 768350-1

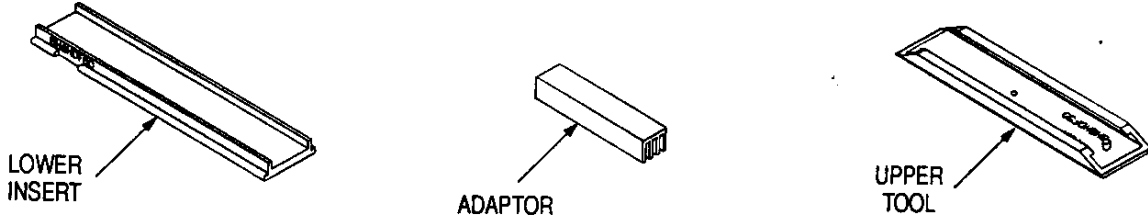

TYPICAL APPLICATIONS

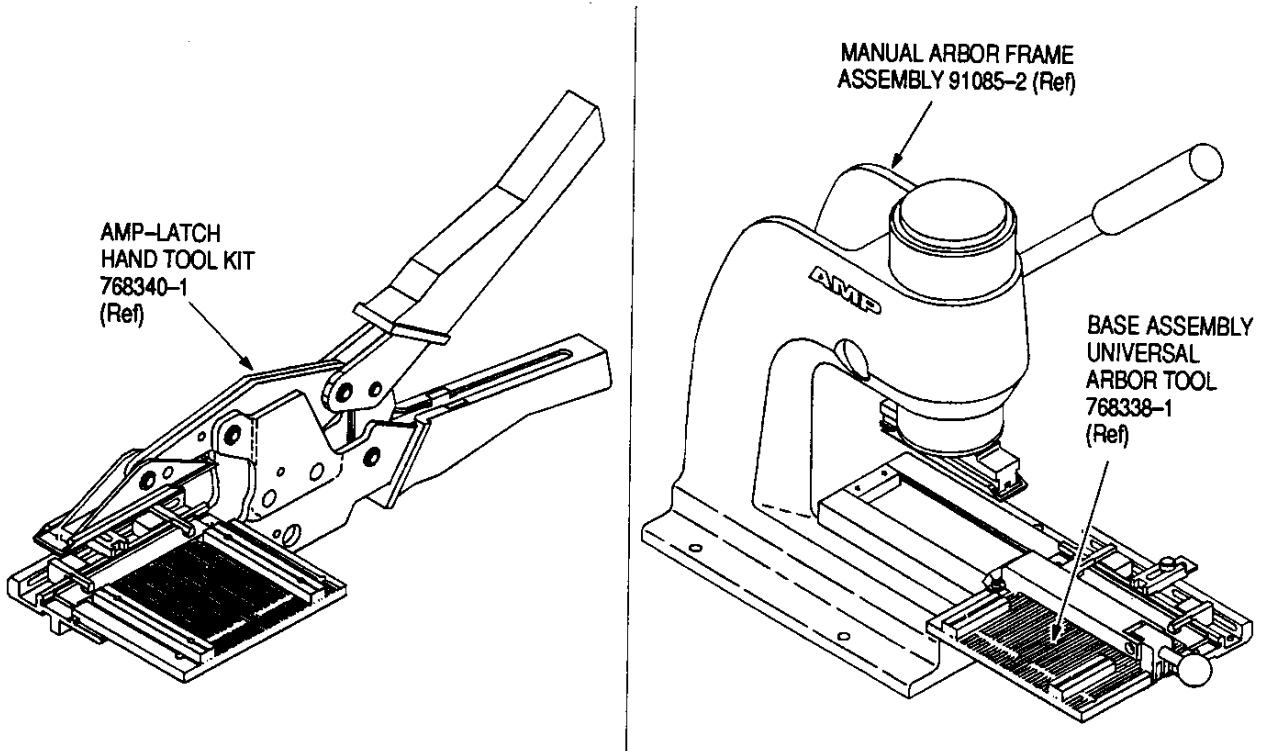

Figure 1

cad

1. INTRODUCTION

This instruction sheet covers the description, cable requirements, and installation procedures for AMP Connector-Specific Kit 768350-1, which is used with AMP-LATCH Hand Tool Kit 768340-1 (see instruction

sheet 408-9828) and Base Assembly Universal Arbor Tool 768338-1 (see 408-9827). The connector-specific kit will terminate AMP-LATCH 50-Position HDF Connectors having 1.27 mm [.050 in.] centerline spacing to ribbon cable (see Figure 2).

The Base Assembly Universal Arbor Tool is used with AMP Manual Arbor Frame Assembly 91085-2 and AMP Pneumatic Auto-Cycle Unit 91112-3. Refer to 408-7777 and 408-6732, respectively, for tooling information.

NOTE

Dimensions on this sheet are in metric units [with U.S. customary equivalents in brackets].

CAUTION

The cable must be cut 90° to the edge of the cable; otherwise an improper termination will result. We suggest you use a guillotine-type cable cutter, such as the Carpenter Model 95 which can be purchased from:

Carpenter Manufacturing Co., Inc.
 Fairgrounds Drive
 Manlius, N.Y. 13207

2. DESCRIPTION (Figure 1)

The connector-specific kit features an upper tool, an adaptor, and a lower insert. The upper tool and the adaptor apply an even force over the length of the connector during termination. The lower insert positions the connector on the tooling assembly. Each component is marked "AMP HDF 50."

3. CABLE REQUIREMENTS

The connector-specific kit will terminate ribbon cable with 26 AWG solid or stranded conductors, 28 AWG solid or stranded conductors, or 30 AWG solid conductors to all AMP-LATCH 50-position HDF Connectors. Refer to Figure 2 for the recommended cable dimensions.

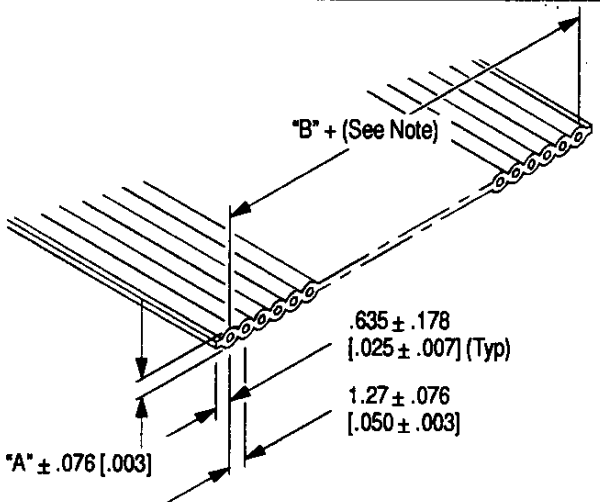

NOTE

ACCUMULATIVE TOLERANCE FOR CABLE CONDUCTORS 1 THROUGH 34 IS + .254 [.010] AND THROUGH 60 IS + .38 [.015].

CONDUCTOR		DIMENSION	
SIZE (AWG)	TYPE	"A"	"B"
26	Stranded or Solid	0.889 mm [.035 IN.]	1.27 mm [.050 IN.] X (Total No. of Conductors Minus One)
28	Stranded or Solid		
30	Solid		

Figure 2

cad 9831

AMP-LATCH HAND TOOL KIT 768340-1 (Ref)
 (Includes AMP-LATCH Hand Tool Subassembly 768942-1 and Base Assembly Universal Hand Tool 768339-1. Refer to 408-9846 and 408-9826)

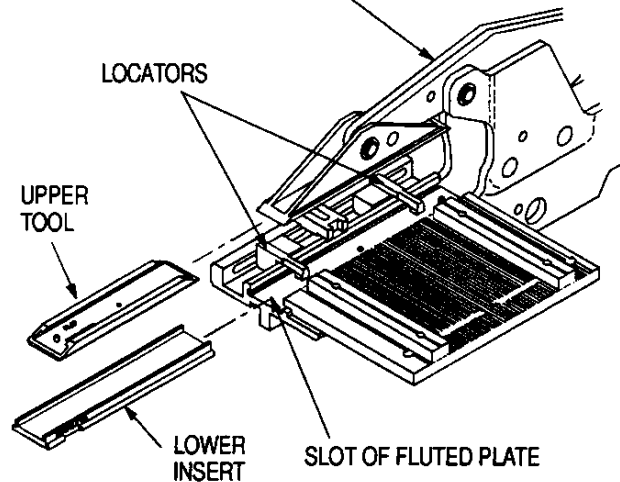

Figure 3

cad

4. CONNECTOR-SPECIFIC KIT INSTALLATION (Figures 3 and 4)

NOTE

For hand tool applications, mount the hand tool onto a suitable work surface, whenever possible, before terminating the connectors. Refer to the bench-clamping instructions in 408-9828, packaged with the AMP-LATCH Hand Tool Kit.

1. Slide the upper tool onto the upper tool mount.
2. Slide the lower insert into the slot of the fluted plate.
3. Place the adaptor into the plug connector prior to termination.

NOTE

When using the hand tool, the upper tool is not used.

NOTE

The adaptor is not needed when terminating receptacle connectors.

This completes the installation procedure.

BASE ASSEMBLY UNIVERSAL
 ARBOR TOOL 768338-1
 (Ref)

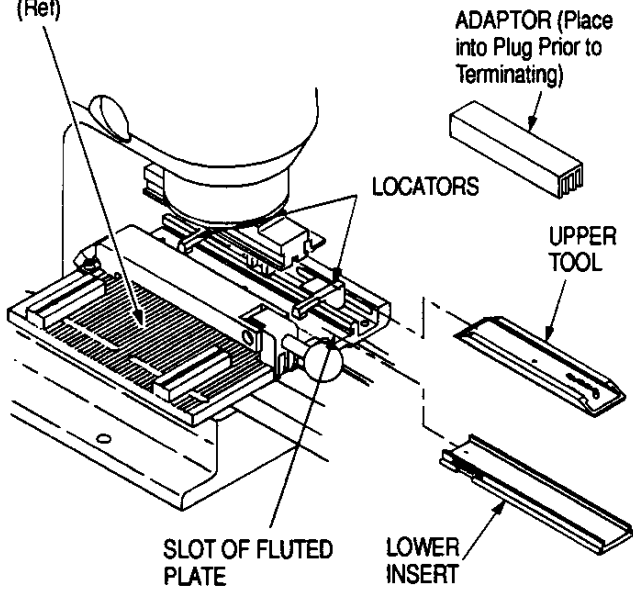

Fig. 4

cad

NOTE

For information concerning termination procedures, refer to 408-9828 packaged with the AMP-LATCH Hand Tool Kit, and 408-9827 packaged with the Base Assembly Universal Arbor Tool.

5. CONNECTOR-SPECIFIC KIT INSPECTION

Connector-Specific Kit 768350-1 has been inspected and should be verified with the information provided in Figure 5. It is recommended that the connector-specific kit be inspected immediately upon its arrival at your facility (and at regularly scheduled intervals) to ensure that the kit components have not been damaged during handling.

For additional information concerning connector-specific kits, or to purchase additional kits, contact your local AMP representative or:

CUSTOMER SERVICE (38-35)
 AMP INCORPORATED
 P.O. BOX 3608
 HARRISBURG, PA 17105-3608

CONNECTOR-SPECIFIC KIT 768350-1

UPPER TOOL

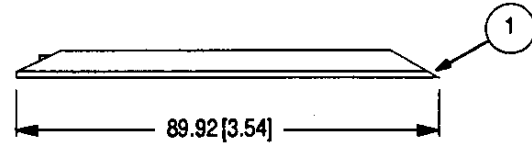
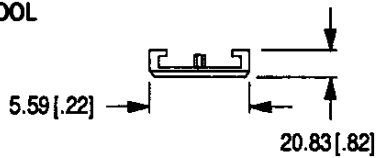

LOWER INSERT

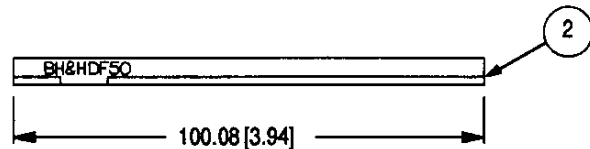
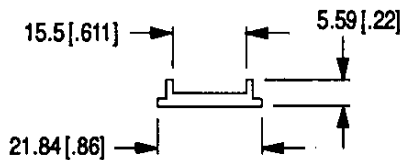

ADAPTOR

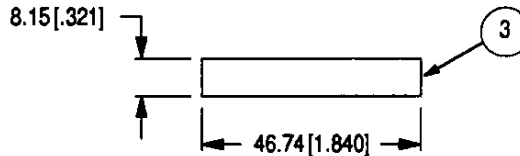
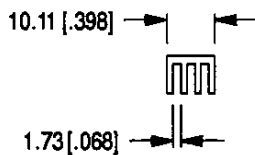

COMPONENT LIST

ITEM NO.	PART NUMBER	DESCRIPTION	QTY
1	543274-6	Upper Tool	1
2	1-543275-1	Lower Insert	1
3	768938-1	Adaptor	1

Figure 5

cad