

Excellent Integrated System Limited

Stocking Distributor

Click to view price, real time Inventory, Delivery & Lifecycle Information:

[TE Connectivity AMP Connectors](#)
[768352-1](#)

For any questions, you can email us directly:

sales@integrated-circuit.com



AMP* Connector-Specific Kit 768352-1
 for EUROLATCH* Connectors

Instruction Sheet
408-9840
 13 MAY 93 Rev A

PROPER USE GUIDELINES

Cumulative Trauma Disorders can result from the prolonged use of manually powered hand tools. AMP hand tools are intended for occasional use and low volume applications. AMP offers a wide selection of powered application equipment for extended-use, production operations.

CONNECTOR-SPECIFIC KIT 768352-1

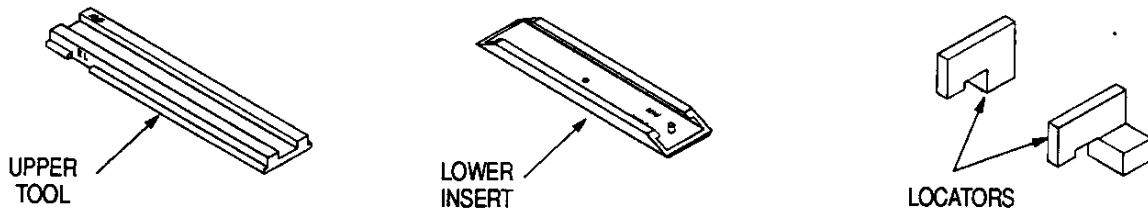

TYPICAL APPLICATIONS

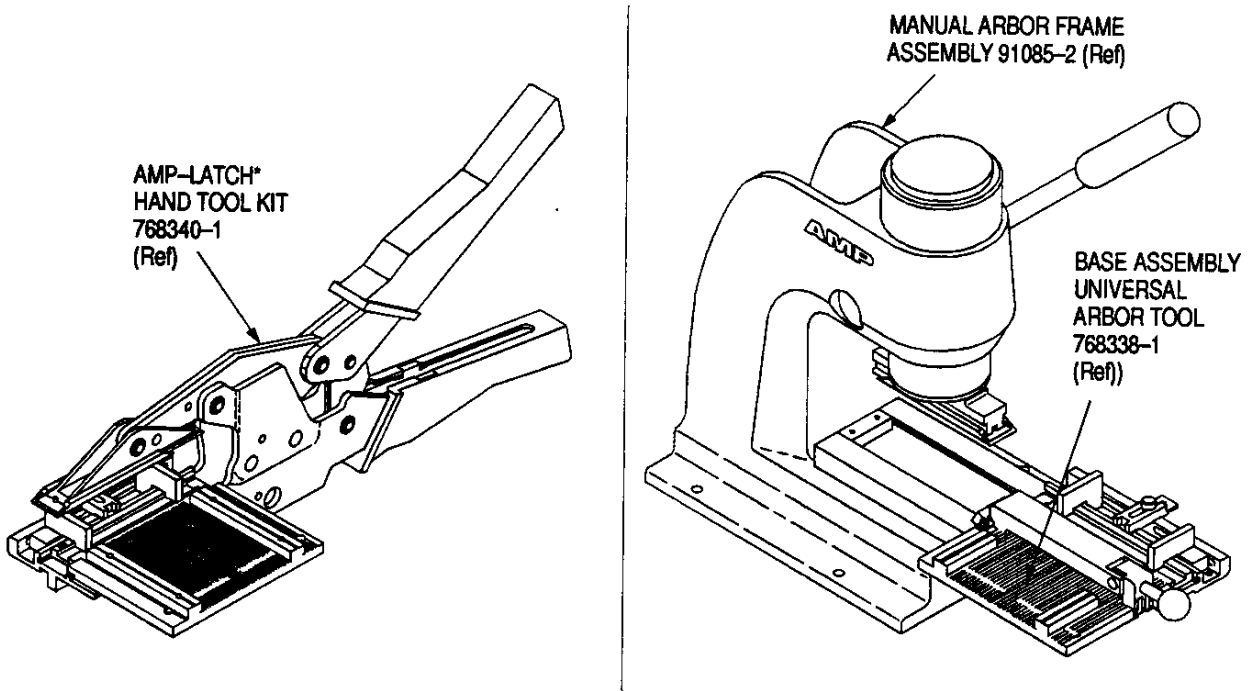

Figure 1

cad

1. INTRODUCTION

This instruction sheet describes AMP Connector-Specific Kit 768352-1, lists cable requirements, and describes installation of the kit. (See Figure 1.)

The connector-specific kit can be used with AMP-LATCH Hand Tool Kit 768340-1 or Base Assembly Universal Arbor Tool 768338-1 (Figure 1)

to terminate EUROLATCH Connectors having 1.27 mm [.050-in.] centerline spacing to ribbon cable. Refer to Figure 2 for cable dimensions.

The Base Assembly Universal Arbor Tool is powered by either AMP Manual Arbor Frame Assembly 91085-2 or AMP Pneumatic Auto-Cycle Unit 91112-3.

NOTE For information concerning AMP EUROLATCH Connectors, refer to AMP Catalog 82012. For detailed information on other tooling components used with Connector-Specific Kit 768352-1, refer to the following instruction sheets:

- 408-6732 — Pneumatic Auto-Cycle Unit 91112-3
- 408-7777 — Manual Arbor Frame Assembly 91085-2
- 408-9827 — Base Assembly Universal Arbor Tool 768338-1
- 408-9828 — AMP-LATCH Hand Tool Kit 768340-1

NOTE All dimensions on this sheet are in metric units [with U.S. customary units in brackets].

2. DESCRIPTION (Figure 1)

The connector-specific kit features an upper tool, two locators, and a lower insert. The upper tool applies an even force over the length of the connector during termination. The lower insert positions the connector on the tooling assembly, and the locators adjust for the different sizes of cables and connectors. Components are marked "EL."

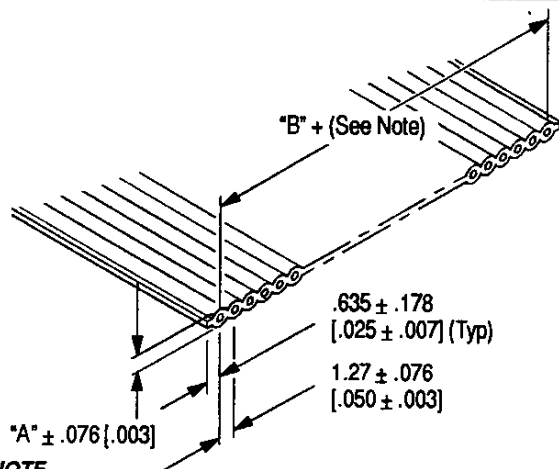

NOTE
 ACCUMULATIVE TOLERANCE FOR CABLE CONDUCTORS 1 THROUGH 34 IS + .254 [.010] AND THROUGH 60 IS + .38 [.015].

CONDUCTOR		DIMENSION	
SIZE (AWG)	TYPE	"A"	"B"
26	Stranded or Solid	0.889 mm [.035 IN.]	1.27 mm [.050 IN.] X (Total No. of Conductors Minus One)
28	Stranded or Solid		
30	Solid		

Figure 2

cad 9831

3. CABLE REQUIREMENTS

The connector-specific kit will terminate EUROLATCH Connectors with 1.27 mm [.050 in.]

centerline spacing to ribbon cable with 26 AWG solid or stranded conductors, 28 AWG solid or stranded conductors, or 30 AWG solid conductors. Refer to Figure 2 for the recommended cable dimensions.

CAUTION The cable must be cut 90° to the edge of the cable; otherwise an improper termination will result. We suggest you use a guillotine-type cable cutter, such as the Carpenter Model 95 which can be purchased from:

Carpenter Manufacturing Co., Inc.
 Fairgrounds Drive
 Manlius, N.Y. 13207

AMP-LATCH HAND TOOL KIT 768340-1 (Ref)
 (Includes AMP-LATCH Hand Tool Subassembly 768942-1 and Base Assembly Universal Hand Tool 768339-1. Refer to 408-9846 and 408-9826)

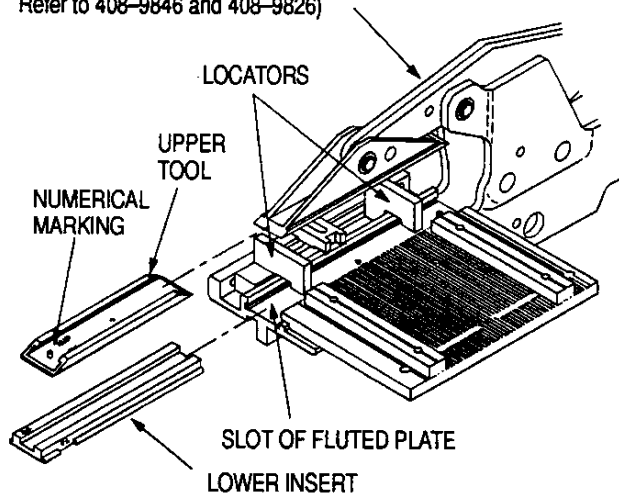

Figure 3

cad

4. CONNECTOR-SPECIFIC KIT INSTALLATION (Figures 3 and 4)

NOTE For hand tool applications, mount the hand tool onto a suitable work surface, whenever possible, before terminating the connectors. Refer to the bench-clamping instructions in 408-9828, packaged with the AMP-LATCH Hand Tool Kit.

1. Slide the upper tool onto the upper tool mount.
2. Slide lower insert into slot of fluted plate.
3. Install locators into base of tool, as shown in Figures 3 and 4.

This completes the installation procedure.

NOTE For information concerning termination procedures, refer to 408-9828 packaged with the hand tool kit, and 408-9827 packaged with the Base Assembly Universal Arbor Tool.

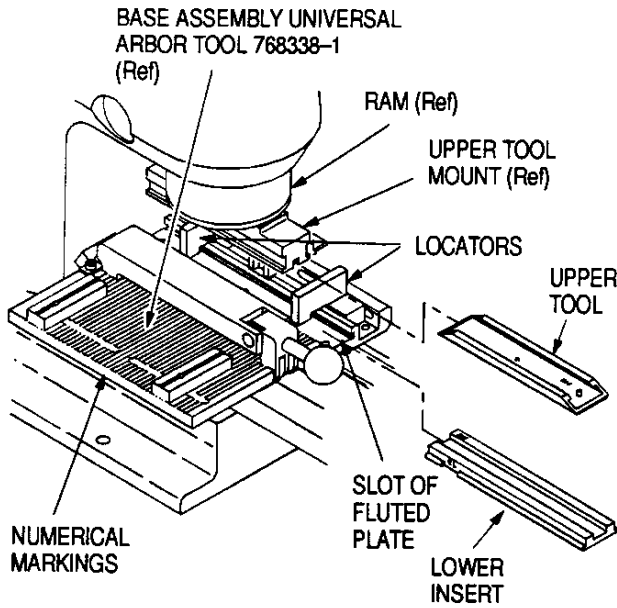

Figure 4 cad

5. CONNECTOR-SPECIFIC KIT INSPECTION

Connector-Specific Kit 768352-1 has been inspected and should be verified with the information provided in Figure 5. It is recommended that the connector-specific kit be inspected immediately upon its arrival at your facility (and at regularly scheduled intervals) to ensure that the kit components have not been damaged during handling.

For additional information concerning connector-specific kits, or to purchase additional kits, contact your local AMP representative or:

CUSTOMER SERVICE (38-35)
 AMP INCORPORATED
 P.O. BOX 3608
 HARRISBURG, PA 17105-3608

CONNECTOR-SPECIFIC KIT 768352-1

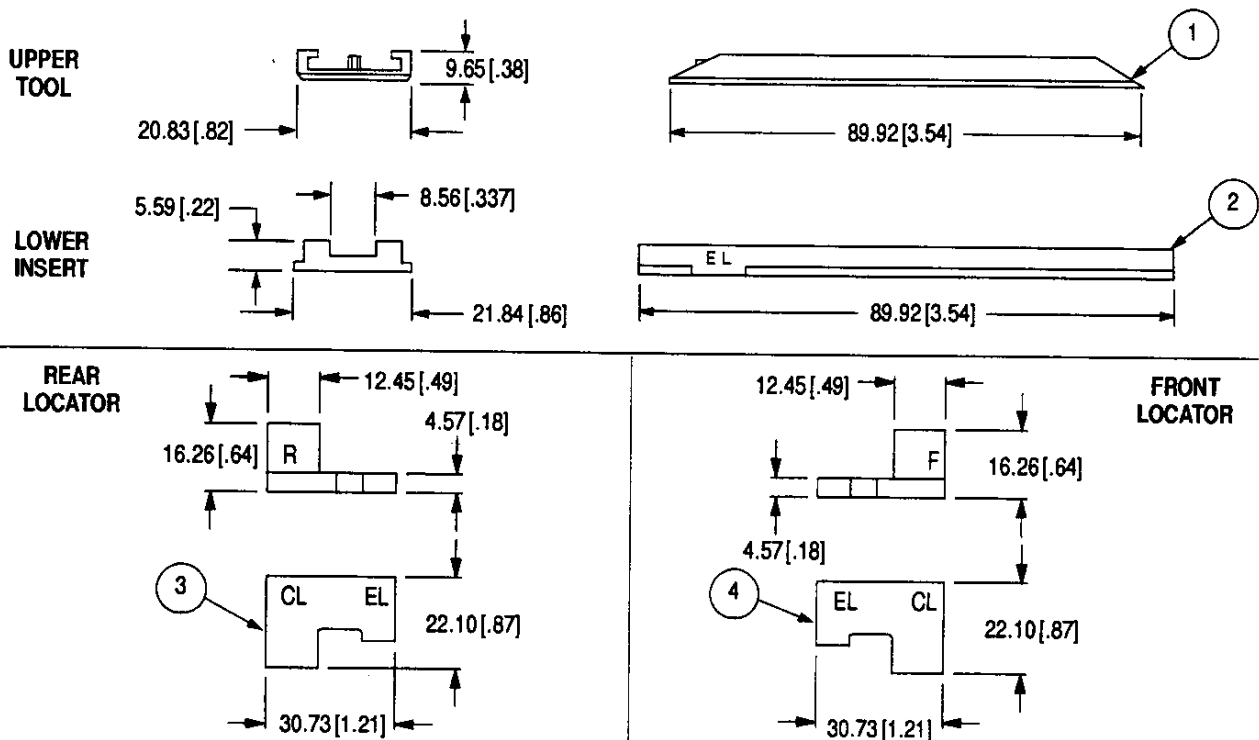

COMPONENT LIST

ITEM NO.	PART NUMBER	DESCRIPTION	QTY
1	543274-1	Upper Tool	1
2	1-543275-2	Lower Insert	1
3	768935-1	Rear Locator	1
4	768936-1	Front Locator	1

Figure 5

cad, cad 9839