

Excellent Integrated System Limited

Stocking Distributor

Click to view price, real time Inventory, Delivery & Lifecycle Information:

[STMicroelectronics](#)
[STAC3932B](#)

For any questions, you can email us directly:

sales@integrated-circuit.com



STAC3932B

HF/VHF/UHF RF power N-channel MOSFET

Datasheet - production data

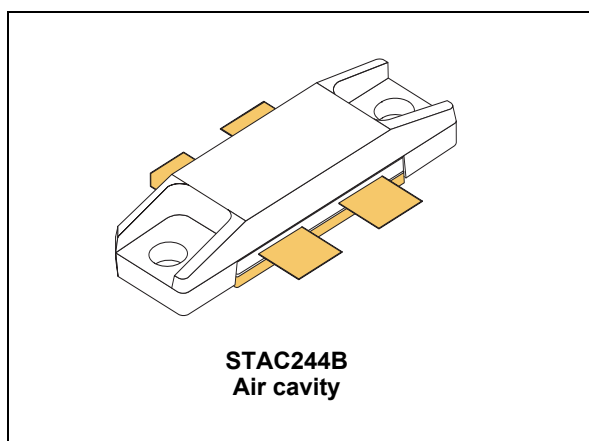

Features

- Excellent thermal stability
- Common source push-pull configuration
- $P_{OUT} = 580\text{ W}$ typ. with 24.6 dB gain @ 123 MHz
- In compliance with the 2002/95/EC European directive

Description

The STAC3932B is an N-channel MOS field-effect RF power transistor. It is intended for use in 100 V DC large signal applications up to 250 MHz.

Figure 1. Pin connection

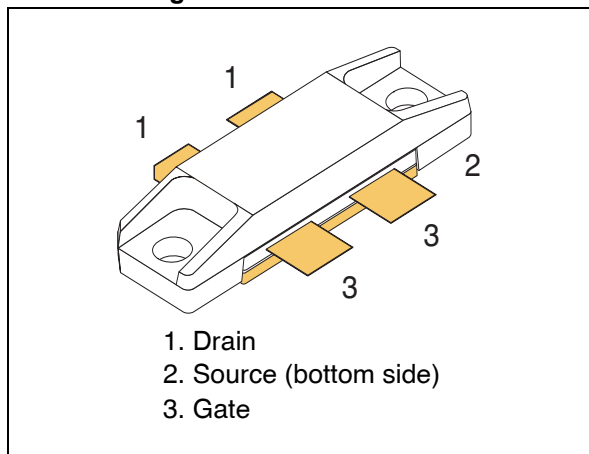

Table 1. Device summary

Order code	Marking	Base qty.	Package	Packaging
STAC3932B	STAC3932 ⁽¹⁾	20	STAC244B	Plastic tray

1. For more details please refer to [Chapter 8: Marking, packing and shipping specifications](#).

Contents

1	Electrical data	3
1.1	Maximum ratings	3
1.2	Thermal data	3
2	Electrical characteristics	4
2.1	Static	4
2.2	Dynamic	4
3	Impedances	5
4	Electrical schematic and BOM	6
5	Circuit layout	8
6	Typical performance	9
7	Package mechanical data	13
8	Marking, packing and shipping specifications	15
9	Revision history	16

1 Electrical data

1.1 Maximum ratings

Table 2. Absolute maximum ratings ($T_{CASE} = 25\text{ }^{\circ}\text{C}$)

Symbol	Parameter	Value	Unit
$V_{(BR)DSS}^{(1)}$	Drain source voltage	250	V
V_{DGR}	Drain-gate voltage ($R_{GS} = 1\text{ M}\Omega$)	250	V
V_{GS}	Gate-source voltage	± 20	V
I_D	Drain current	20	A
P_{DISS}	Power dissipation	625	W
T_J	Max. operating junction temperature	200	$^{\circ}\text{C}$
T_{STG}	Storage temperature	-65 to +150	$^{\circ}\text{C}$

1. $T_J = 150\text{ }^{\circ}\text{C}$

1.2 Thermal data

Table 3. Thermal data

Symbol	Parameter	Value	Unit
R_{thJC}	Junction - case thermal resistance	0.28	$^{\circ}\text{C/W}$

Electrical characteristics

STAC3932B

2 Electrical characteristics

(T_{CASE} = 25 °C)

2.1 Static

Table 4. Static (per side)

Symbol	Test conditions		Min.	Typ.	Max.	Unit
V _{(BR)DSS}	V _{GS} = 0 V	I _{DS} = 100 mA	250			V
I _{DSS}	V _{GS} = 0 V	V _{DS} = 100 V			1	mA
I _{GSS}	V _{GS} = 20 V	V _{DS} = 0 V			250	nA
V _{TH}	I _D = 250 mA		2.0		4.0	
V _{DS(ON)}	V _{GS} = 10 V	I _D = 5 A		2.5	3.5	V
G _{FS}	V _{DS} = 10 V	I _D = 2.5 A	3.0		5.0	S
C _{ISS}	V _{GS} = 0 V V _{DS} = 100 V f = 1 MHz			492		pF
C _{OSS}				134		pF
C _{RSS}				5.2		pF

2.2 Dynamic

Table 5. Dynamic CW

Symbol	Test conditions	Min.	Typ.	Max.	Unit
P _{OUT}	V _{DD} = 100 V, I _{DQ} = 2 x 250 mA, P _{IN} = 2 W, f = 123 MHz	450	580	-	W
h _D	V _{DD} = 100 V, I _{DQ} = 2 x 250mA, P _{IN} = 2 W, f = 123 MHz		70	-	%

Table 6. Pulse / 1 msec - 10%

Symbol	Test conditions	Min.	Typ.	Max.	Unit
P _{OUT}	V _{DD} = 100 V, I _{DQ} = 2 x 250 mA, P _{IN} = 8 W, f = 123 MHz	-	900	-	W
h _D	V _{DD} = 100 V, I _{DQ} = 2 x 250mA, P _{IN} = 8 W, f = 123 MHz	-	65	-	%

3 Impedances

Figure 2. Impedance data

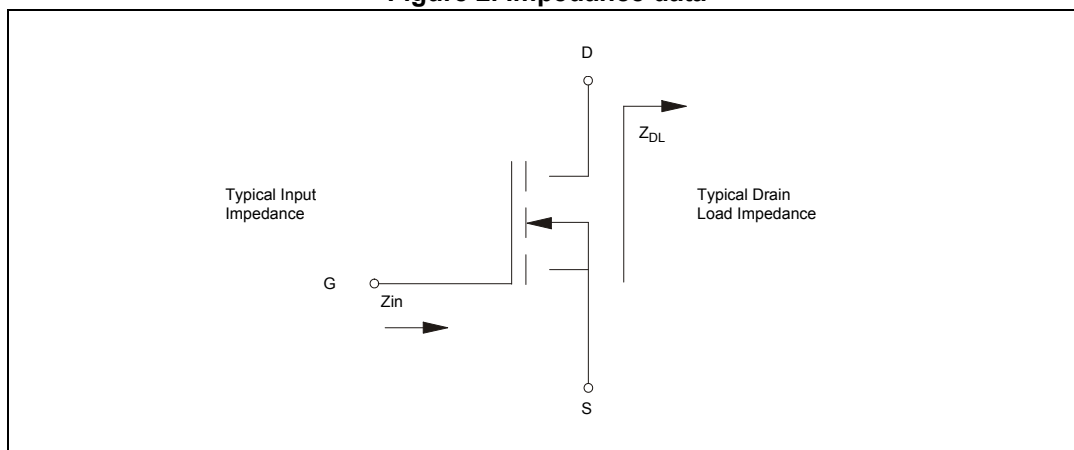

Table 7. Impedance data

Freq.	Z_{IN} (Ω)	Z_{DL} (Ω)
123 MHz (pulse)	$1.0 - j 4.80$	$6.3 + j 10.5$
123 MHz (CW)	$0.8 - j 3.45$	$5.0 + j 13.0$
64 MHz	$1.4 - j 10.0$	$12.8 + j 14.0$

Note: Measured gate-to-gate and drain-to-drain, respectively.

4 Electrical schematic and BOM

Figure 3. Electrical schematic

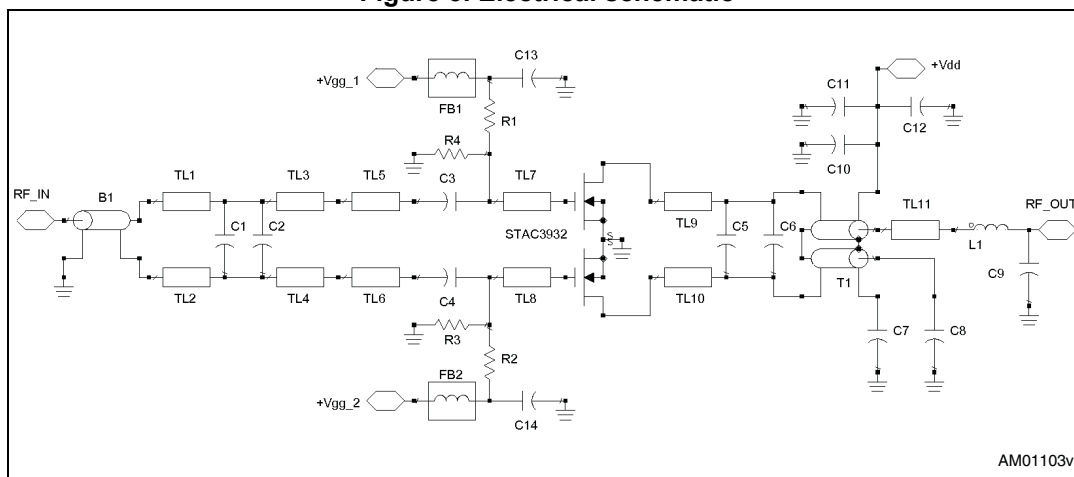

Table 8. Bill of materials

Component	Description
C1	270 pF ATC 100B chip capacitor
C2	180 pF ATC 100B chip capacitor
C3, C4	750 pF ATC 700B chip capacitor
C5, C8	43 pF ATC 100B chip capacitor
C6	20 pF ATC 100B chip capacitor
C7	1000 pF ATC 100C chip capacitor
C9	5.6 pF ATC 100B chip capacitor
C10	2200 pF ATC 100C chip capacitor
C11	470 pF ATC 100B chip capacitor
C12	100 μF, 200 V electrolytic capacitor
C13, C14	1200 pF ATC 700B chip capacitor
R1, R2	15 Ω 1/4 watt chip resistor
R3, R4	30 Ω 1/4 watt axial lead resistor
L1	3 turns, 16 ga magnet wire, Id 3/8", .165" turn spacing, 78 nH
FB1, FB2	Ferrite bead, Fair-Rite # 2743019447
B1	1/4λ balun transformer, RG316-25Ω, 16.5"
T1	20 ga Teflon-coated wire through 4 copper tubes OD 1/8" x 1.5"
TL1, TL2	0.740" x 0.200" microstrip
TL3, TL4	0.360" x 0.200" microstrip

STAC3932B

Electrical schematic and BOM

Table 8. Bill of materials (continued)

Component	Description
TL5, TL6	0.480" x 0.350" microstrip
TL7, TL8	0.220" x 0.350" microstrip
TL9, TL10	0.350" x 0.660" microstrip
TL11	0.415" x 0.200" microstrip
Board	0.062" FR-4

5 Circuit layout

Figure 4. Circuit photo

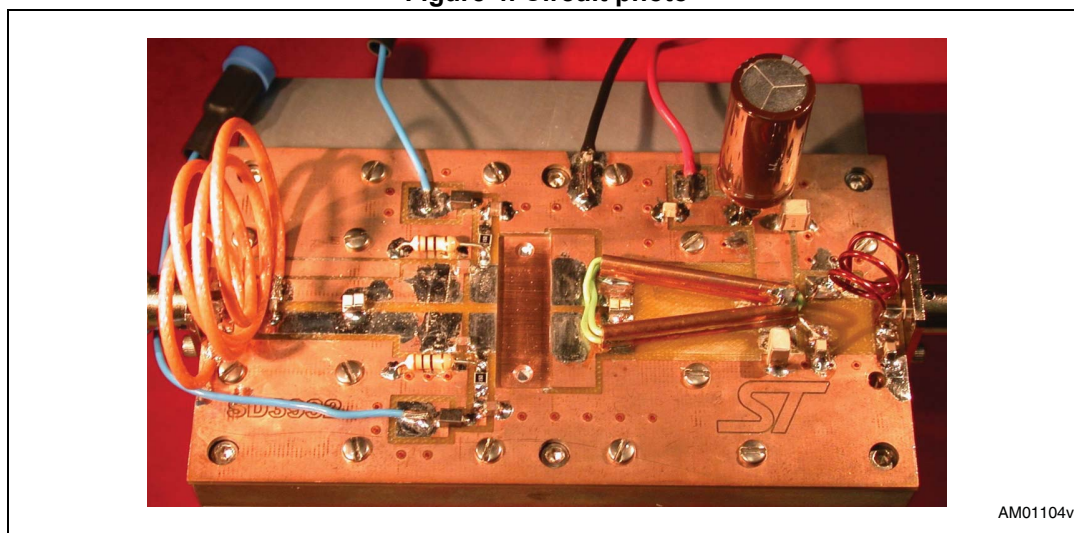
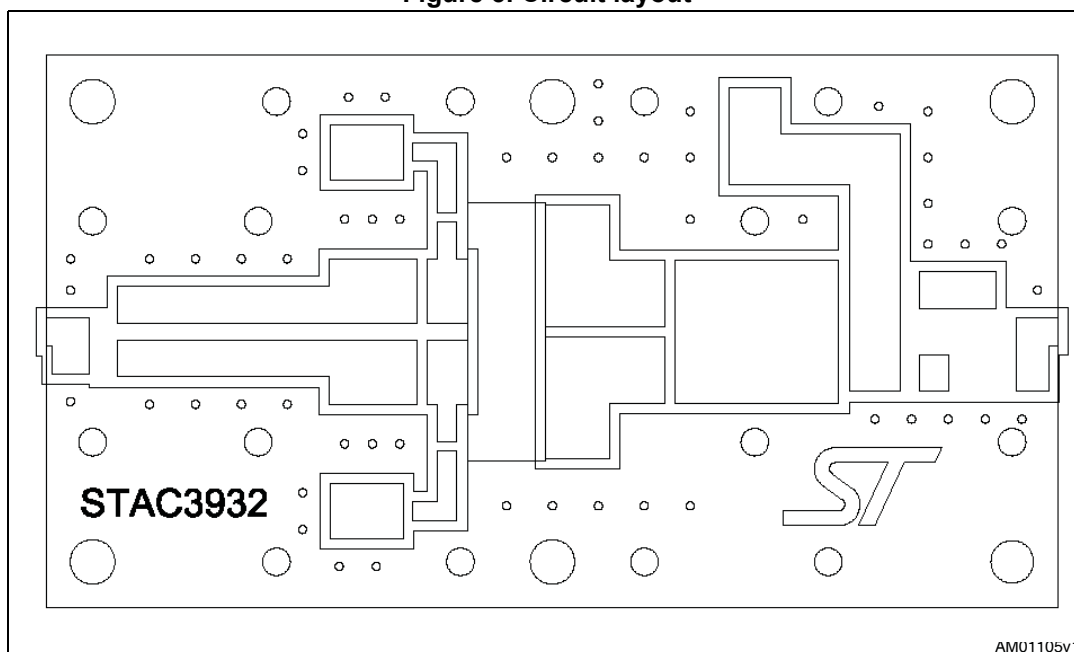

Figure 5. Circuit layout



6 Typical performance

Figure 6. Capacitances vs. drain supply voltage

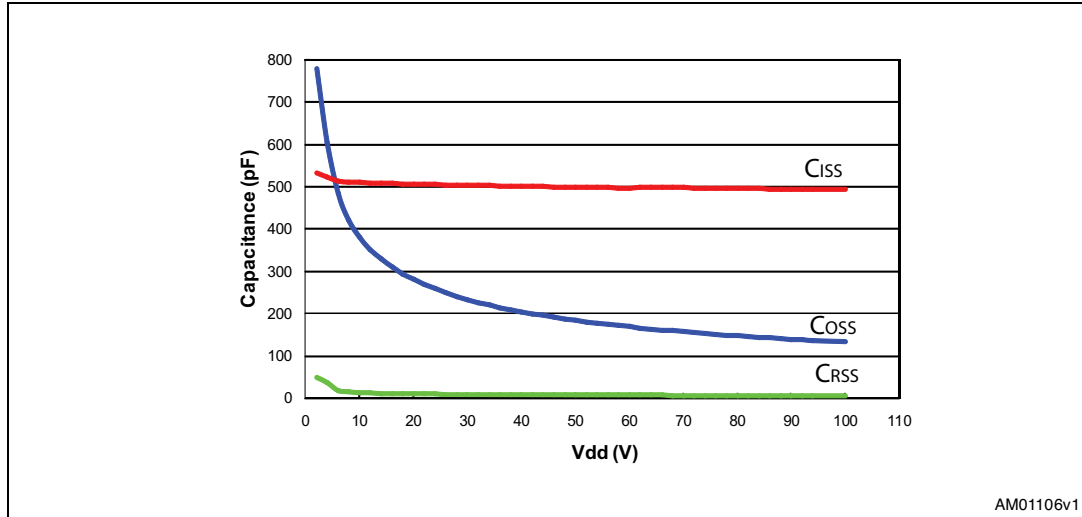
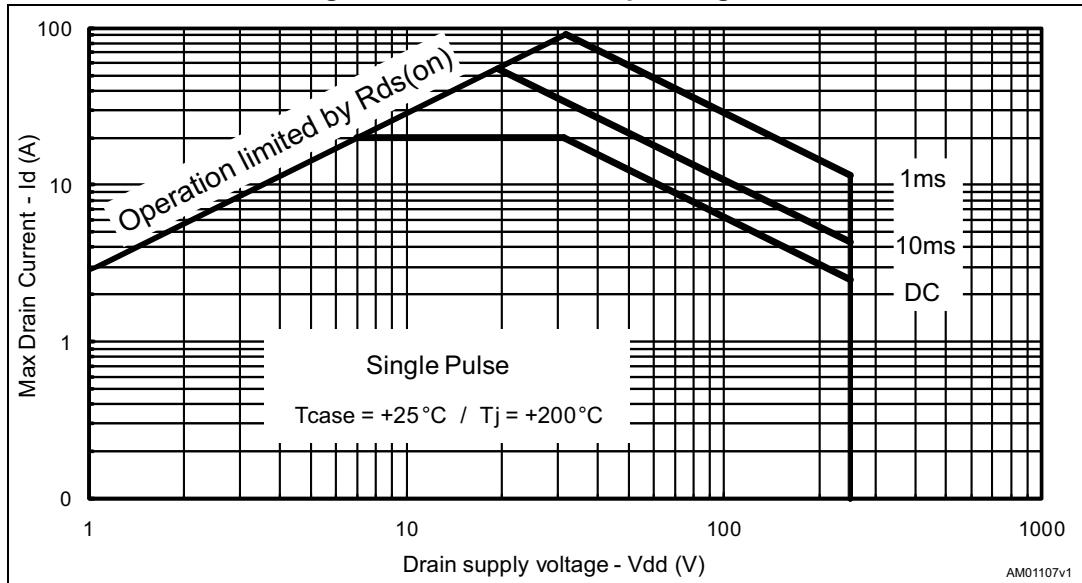

Figure 7. Maximum safe operating area



Typical performance

STAC3932B

Figure 8. Transient thermal impedance

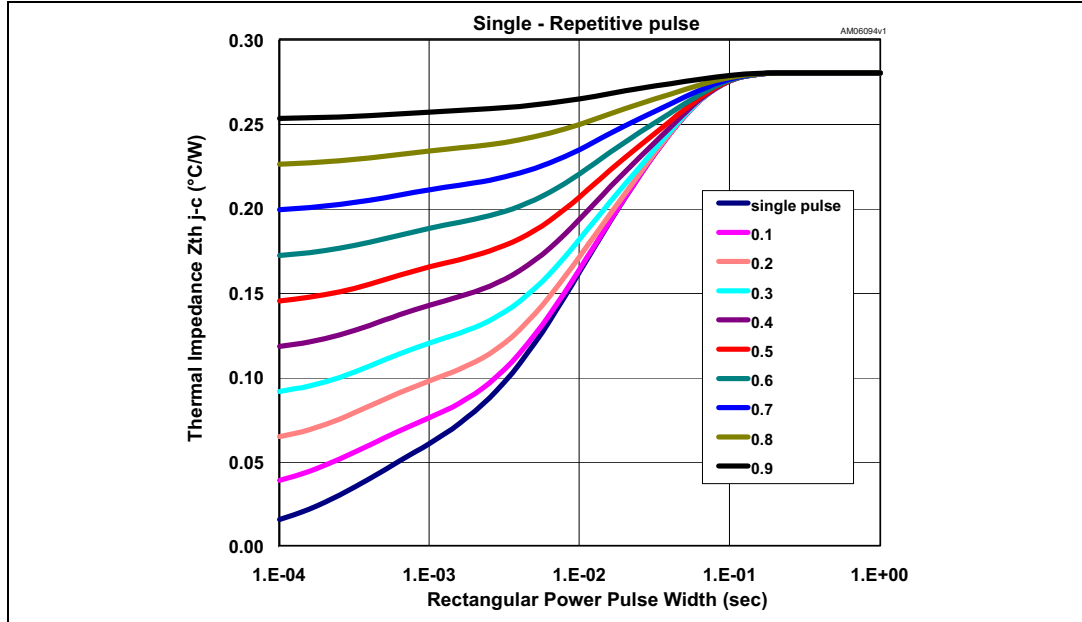
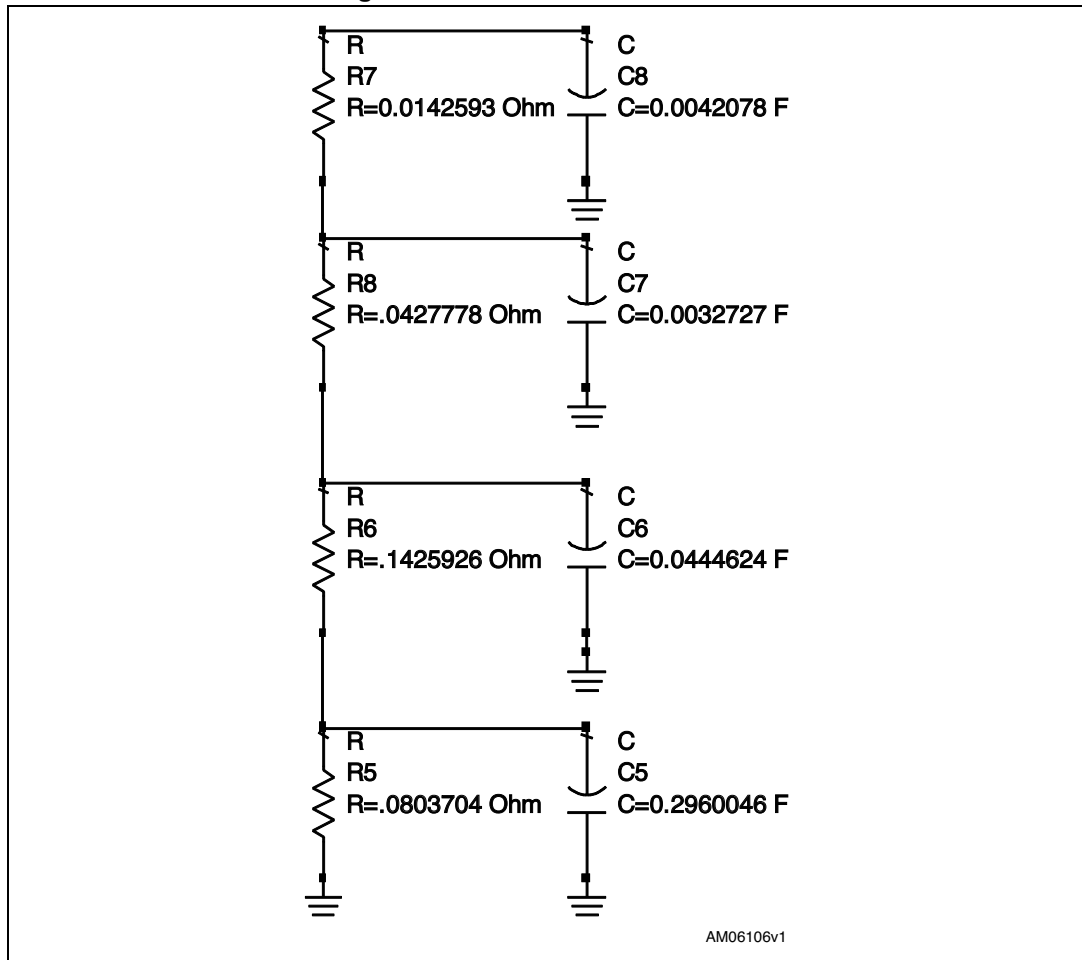

Figure 9. Transient thermal model



STAC3932B

Typical performance

Figure 10. Zero temperature coefficient point

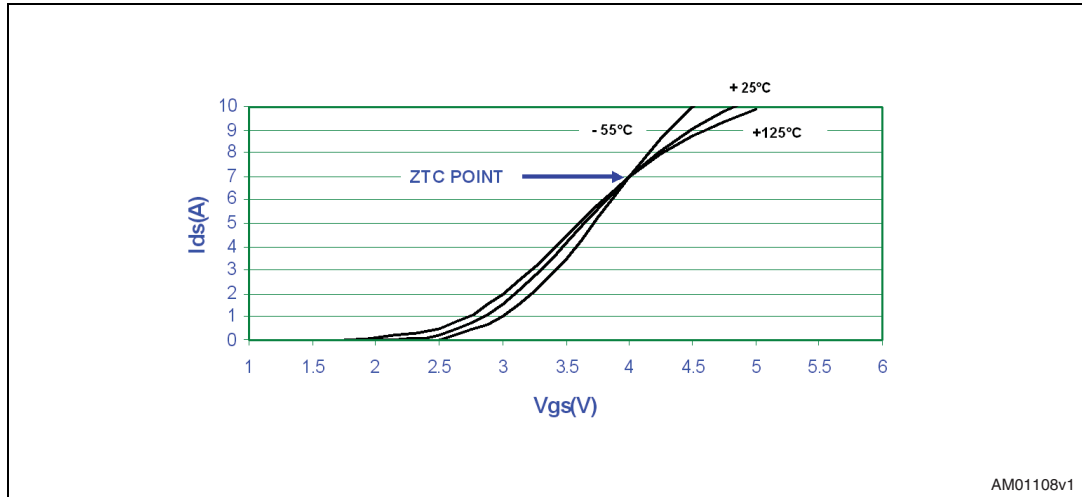

AM01108v1

Figure 11. Output power and efficiency vs. input power (CW)

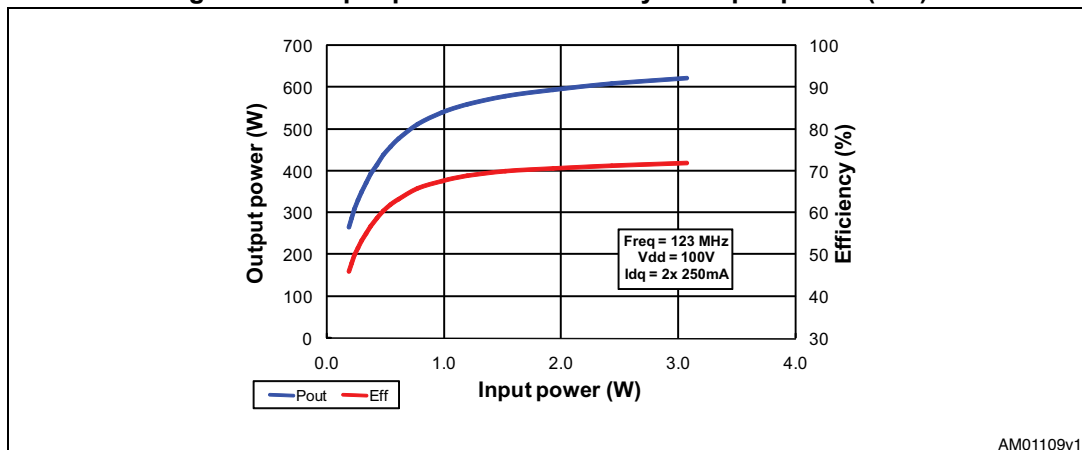

AM01109v1

Figure 12. Gain vs. output power (CW)

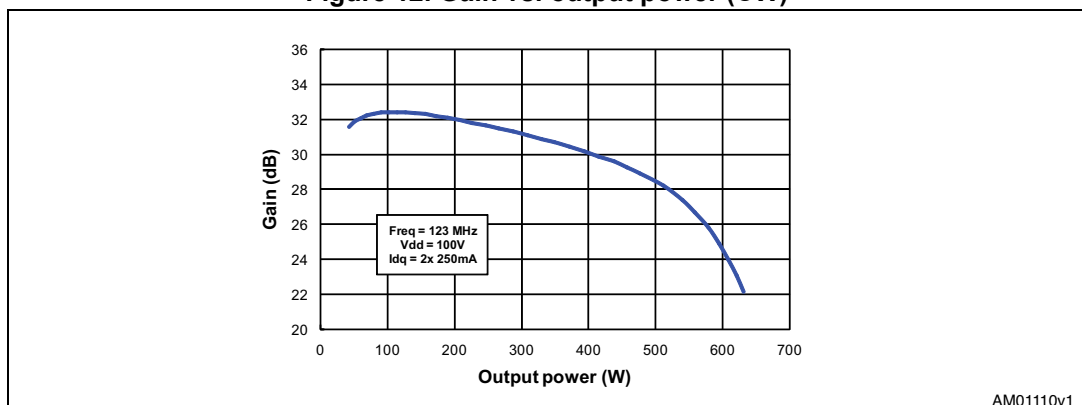

AM01110v1

Typical performance

STAC3932B

Figure 13. Output power and efficiency vs. input power (1 msec - 10%)

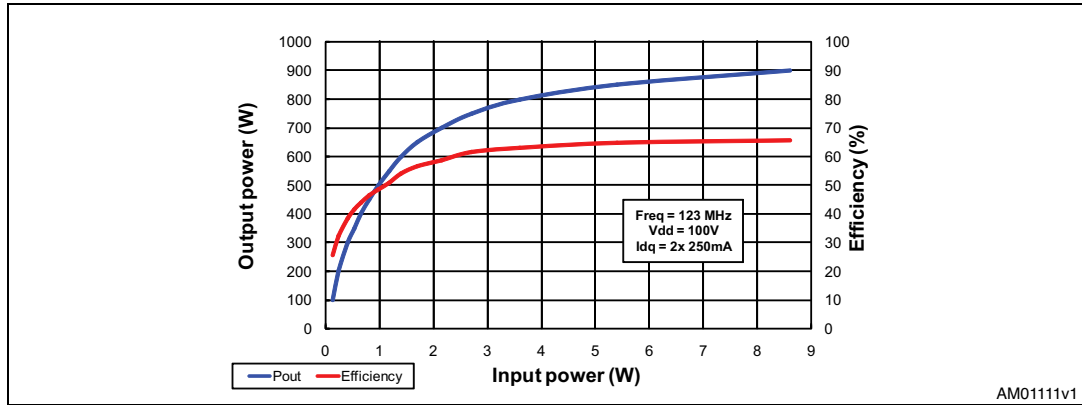

7 Package mechanical data

In order to meet environmental requirements, ST offers these devices in different grades of ECOPACK® packages, depending on their level of environmental compliance. ECOPACK® specifications, grade definitions and product status are available at: www.st.com. ECOPACK is an ST trademark.

Table 9. STAC244B mechanical data

Dim.	mm		
	Min.	Typ.	Max.
A	5.08		5.59
A1	4.32		4.83
B	4.32		5.33
C	9.65		9.91
D	17.78		18.08
E	33.88		34.19
F	0.10		0.15
G		1.02	
H	1.45		1.70
I	4.83		5.33
J	9.27		9.52
K	27.69		28.19
L		3.23	
M		3.45	

Package mechanical data

STAC3932B

Figure 14. STAC244B mechanical data drawing

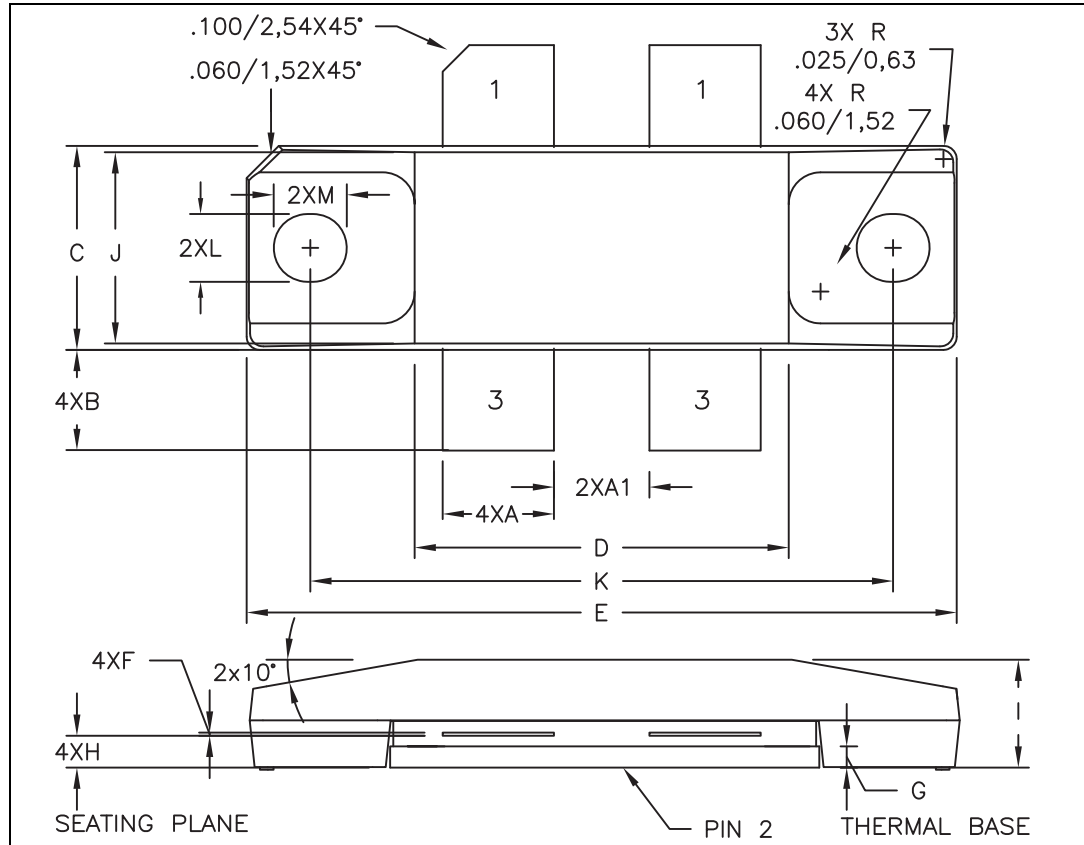

8 Marking, packing and shipping specifications

Table 10. Packing and shipping specifications

Order code	Packaging	Pcs per tray	Dry pack humidity	Lot code
STAC3932B	Tray	20	< 10%	Not mixed

Figure 15. Marking layout

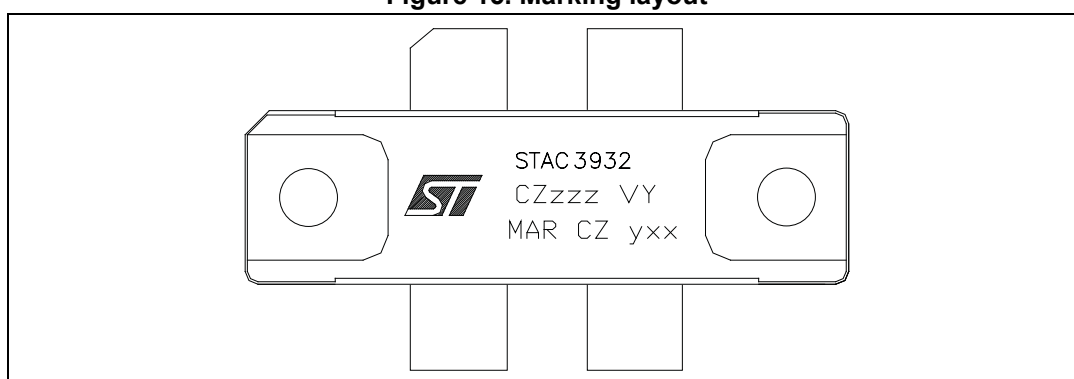

Table 11. Marking specifications

Symbol	Description
CZ	Assembly plant
zzz	Last 3 digits of diffusion lot
VY	Diffusion plant
MAR	Country of origin
CZ	Test and finishing plant
y	Assembly year
xx	Assembly week

9 Revision history

Table 12. Document revision history

Date	Revision	Changes
06-Mar-2009	1	First release.
18-Feb-2010	2	Updated description on cover page
16-Mar-2010	3	Updated <i>Figure 7: Maximum safe operating area</i> . Added <i>Figure 8: Transient thermal impedance</i> . and <i>Figure 9: Transient thermal model</i> .
06-Jul-2011	4	Updated <i>Chapter 7: Package mechanical data</i> . Added <i>Chapter 8: Marking, packing and shipping specifications</i> .
22-Sep-2011	5	Update values for L and M in <i>Table 9: STAC244B mechanical data</i> .
01-Jul-2013	6	Modified pin labeling in <i>Figure 1: Pin connection</i> . Minor text corrections throughout document.

STAC3932B

Please Read Carefully:

Information in this document is provided solely in connection with ST products. STMicroelectronics NV and its subsidiaries ("ST") reserve the right to make changes, corrections, modifications or improvements, to this document, and the products and services described herein at any time, without notice.

All ST products are sold pursuant to ST's terms and conditions of sale.

Purchasers are solely responsible for the choice, selection and use of the ST products and services described herein, and ST assumes no liability whatsoever relating to the choice, selection or use of the ST products and services described herein.

No license, express or implied, by estoppel or otherwise, to any intellectual property rights is granted under this document. If any part of this document refers to any third party products or services it shall not be deemed a license grant by ST for the use of such third party products or services, or any intellectual property contained therein or considered as a warranty covering the use in any manner whatsoever of such third party products or services or any intellectual property contained therein.

UNLESS OTHERWISE SET FORTH IN ST'S TERMS AND CONDITIONS OF SALE ST DISCLAIMS ANY EXPRESS OR IMPLIED WARRANTY WITH RESPECT TO THE USE AND/OR SALE OF ST PRODUCTS INCLUDING WITHOUT LIMITATION IMPLIED WARRANTIES OF MERCHANTABILITY, FITNESS FOR A PARTICULAR PURPOSE (AND THEIR EQUIVALENTS UNDER THE LAWS OF ANY JURISDICTION), OR INFRINGEMENT OF ANY PATENT, COPYRIGHT OR OTHER INTELLECTUAL PROPERTY RIGHT.

ST PRODUCTS ARE NOT AUTHORIZED FOR USE IN WEAPONS. NOR ARE ST PRODUCTS DESIGNED OR AUTHORIZED FOR USE IN: (A) SAFETY CRITICAL APPLICATIONS SUCH AS LIFE SUPPORTING, ACTIVE IMPLANTED DEVICES OR SYSTEMS WITH PRODUCT FUNCTIONAL SAFETY REQUIREMENTS; (B) AERONAUTIC APPLICATIONS; (C) AUTOMOTIVE APPLICATIONS OR ENVIRONMENTS, AND/OR (D) AEROSPACE APPLICATIONS OR ENVIRONMENTS. WHERE ST PRODUCTS ARE NOT DESIGNED FOR SUCH USE, THE PURCHASER SHALL USE PRODUCTS AT PURCHASER'S SOLE RISK, EVEN IF ST HAS BEEN INFORMED IN WRITING OF SUCH USAGE, UNLESS A PRODUCT IS EXPRESSLY DESIGNATED BY ST AS BEING INTENDED FOR "AUTOMOTIVE, AUTOMOTIVE SAFETY OR MEDICAL" INDUSTRY DOMAINS ACCORDING TO ST PRODUCT DESIGN SPECIFICATIONS. PRODUCTS FORMALLY ESCC, QML OR JAN QUALIFIED ARE DEEMED SUITABLE FOR USE IN AEROSPACE BY THE CORRESPONDING GOVERNMENTAL AGENCY.

Resale of ST products with provisions different from the statements and/or technical features set forth in this document shall immediately void any warranty granted by ST for the ST product or service described herein and shall not create or extend in any manner whatsoever, any liability of ST.

ST and the ST logo are trademarks or registered trademarks of ST in various countries.
Information in this document supersedes and replaces all information previously supplied.

The ST logo is a registered trademark of STMicroelectronics. All other names are the property of their respective owners.

© 2013 STMicroelectronics - All rights reserved

STMicroelectronics group of companies

Australia - Belgium - Brazil - Canada - China - Czech Republic - Finland - France - Germany - Hong Kong - India - Israel - Italy - Japan - Malaysia - Malta - Morocco - Philippines - Singapore - Spain - Sweden - Switzerland - United Kingdom - United States of America

www.st.com