

Excellent Integrated System Limited

Stocking Distributor

Click to view price, real time Inventory, Delivery & Lifecycle Information:

[Connor-Winfield](#)
[HSM536-8.0000](#)

For any questions, you can email us directly:

sales@integrated-circuit.com

CRYSTAL CONTROLLED OSCILLATORS

5.0V SURFACE MOUNT 11x6.35mm HCMOS CLOCK OSCILLATOR



HSM546, HSM516
 HSM526, HSM536

ABSOLUTE MAXIMUM RATINGS

PARAMETER	UNITS	MINIMUM	NOMINAL	MAXIMUM	UNITS	NOTE
Storage Temperature		-55	-	125	°C	
Supply Voltage	(Vcc)	-0.5	-	7.0	Vdc	

TABLE 1.0

MODEL SPECIFICATIONS:

MODEL HSM546

PARAMETER	UNITS	MINIMUM	NOMINAL	MAXIMUM	UNITS	NOTE
Frequency Range	(Fo)	1.8	-	80	MHz	
Frequency Tolerance:		-20	-	20	ppm	1

TABLE 2.0

MODEL HSM516

PARAMETER	UNITS	MINIMUM	NOMINAL	MAXIMUM	UNITS	NOTE
Frequency Range	(Fo)	1.8	-	80	MHz	
Frequency Tolerance:		-25	-	25	ppm	1

MODEL HSM526

PARAMETER	UNITS	MINIMUM	NOMINAL	MAXIMUM	UNITS	NOTE
Frequency Range	(Fo)	1.8	-	80	MHz	
Frequency Tolerance:		-50	-	50	ppm	1

MODEL HSM536

PARAMETER	UNITS	MINIMUM	NOMINAL	MAXIMUM	UNITS	NOTE
Frequency Range	(Fo)	1.8	-	80	MHz	
Frequency Tolerance:		-100	-	100	ppm	1

OPERATING SPECIFICATIONS

PARAMETER	MINIMUM	NOMINAL	MAXIMUM	UNITS	NOTE
Operating Temperature Range	0	-	70	°C	
Supply Voltage	(Vdd)	4.5	5.0	5.5	Vdc
Supply Current	1.8 to 19.999 MHz 20 to 49.999 MHz 50 to 69.999 MHz 70 to 80.0 MHz	(Icc)	-	20	mA
		(Icc)	-	30	mA
		(Icc)	-	50	mA
		(Icc)	-	80	mA

TABLE 3.0

INPUT CHARACTERISTICS

PARAMETER	MINIMUM	NOMINAL	MAXIMUM	UNITS	NOTE
Enable Voltage	(Vih)	2.2	-	-	Vdc
Disable Voltage	(Vil)	-	-	.08	Vdc
Enable Time		-	-	100	nS
Disable Time		-	-	100	nS

TABLE 4.0

HCMOS OUTPUT CHARACTERISTICS

PARAMETER	MINIMUM	NOMINAL	MAXIMUM	UNITS	NOTE
LOAD	-	-	50	pF	
Voltage	(Voh)	4.50	-	-	Vdc
	(Vol)	-	-	0.50	Vdc
Current	(Ioh)	-16	-	-	mA
	(Iol)	-	-	16	mA
Duty Cycle at 50% of Vcc	45	50	55	%	
Rise / Fall Time 10% to 90%	-	-	5	nS	
Start-Up Time	-	-	10	mS	
Jitter (BW=10Hz to 20MHz)	-	-	5	ps rms	
Jitter (BW=12kHz to 20MHz)	-	-	1	ps rms	

TABLE 5.0

PACKAGE CHARACTERISTICS

Package	Hermetically sealed ceramic package and metal cover
---------	---

TABLE 6.0

Note:

- Inclusive of calibration @ 25°C, frequency vs. temperature stability, supply voltage change, load change, shock and vibration, 10 years aging.
- Oscillator output is enabled with no connection on pad 1

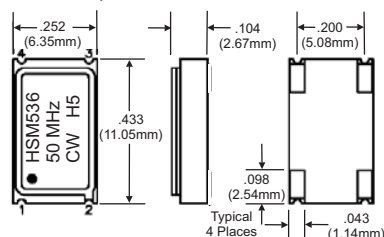

PAD	CONNECTION
1	ENABLE/DISABLE
2	GROUND
3	OUTPUT
4	Vcc

Dimensional Tolerance: ±.02" (.508mm)
 ±.005" (.127mm)

ORDERING INFORMATION

HSM536 - 50 MHz



CRYSTAL CONTROLLED OSCILLATORS

ENVIRONMENTAL CHARACTERISTICS	TEST CIRCUIT
<p>TEMPERATURE CYCLE: The specimen shall meet electrical characteristics after tested 5 cycles of -55°C/30 min & +125°C/30 min.</p> <p>HERMETICAL No bubbles appear in Flourinert (FC-43) at 125°C ±5°C, for 5 minutes.</p> <p>SOLVENT RESISTANCE: Marking will withstand immersion in Isopropyl Alcohol or Trichloroethylene.</p>	
<p>SOLDERING</p>	<p>OUTPUT WAVEFORM</p>
<p>GENERAL CONDITIONS: 280°C max x 10 sec max x 2 times max or 230°C max x 180 sec max x 1 time.</p> <p>TYPICAL OPERATION DATA (Vapor phase reflow) 20 to 100 sec up to 215°C, 50 sec at 215°C then down to room temperature per 1 to 5°C/sec</p>	
<p>MECHANICAL CHARACTERISTICS</p>	<p>SUGGESTED PAD LAYOUT</p>
<p>FREE DROP: The specimen shall meet electrical characteristics after tested 3 times Free Drop testing on the hard wooden board from a height of 75cm.</p> <p>VIBRATION: The specimen shall meet electrical characteristics after tested by the following conditions: 10-55Hz 1.5mm Amplitude, 55-2000Hz 20G's, 2 hours for each plane.</p> <p>THERMAL SHOCK: After applied Thermal Shock of 260°C max x 10 sec max x 2 times, or 230°C max x 180 sec max, the specimen shall meet electrical characteristics.</p> <p>SOLDERABILITY: (EIAJ-RGX-0102/101 Condition 1a) 1. Flux: MIL-F-14256 (WW Rosin=25%, Isopropyl alcohol=75%) 2. Solder: QQ-S-571 (Sn=83%, Pb=37%) 3. Solder bath temperature: 235°C ±5°C. 4. Depth of immersion: Up to electrical terminal. 5. Immersing time: Within 2 sec ±0.5 sec into solder bath. After performing the above procedures, a newly soldered coverage shall be greater than 90%.</p>	<p>Bypass capacitor, C-by, should be ceramic capacitor ≥ .01uf.</p>
<p>TAPING AND REEL DIMENSIONS</p>	<p>SOLDER PROFILE</p>

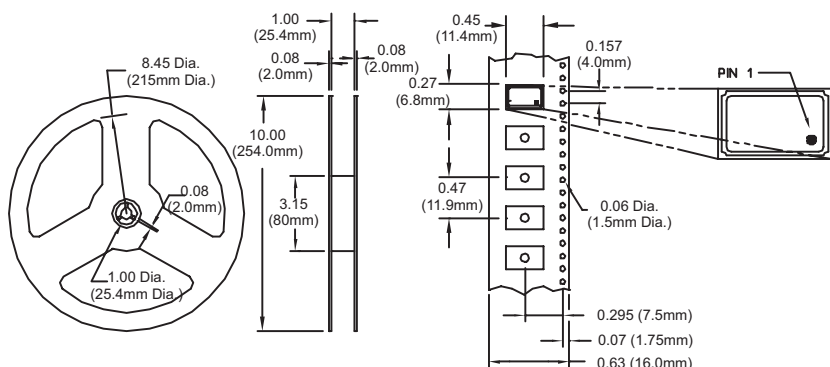

MEETS EIA-481A AND EIAJ-1009B
 1000 PCS / REEL

