

Excellent Integrated System Limited

Stocking Distributor

Click to view price, real time Inventory, Delivery & Lifecycle Information:

[Hammond Manufacturing](#)
[1591XXTBK](#)

For any questions, you can email us directly:

sales@integrated-circuit.com

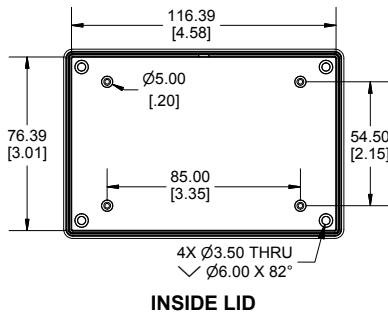
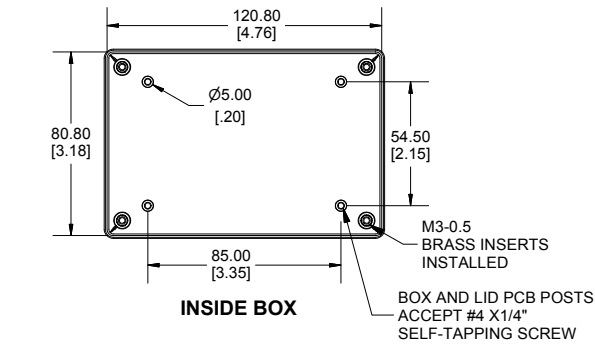
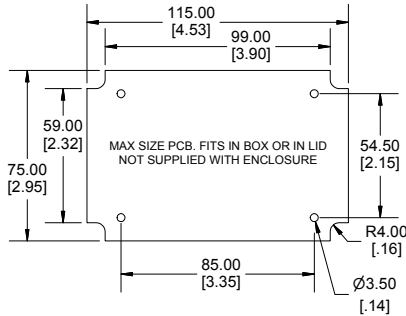
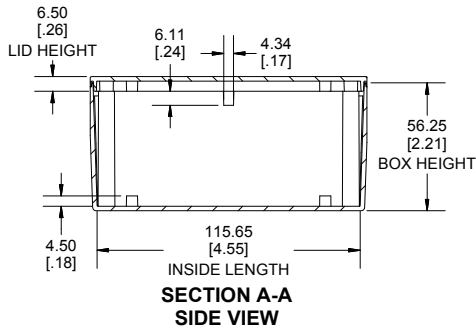
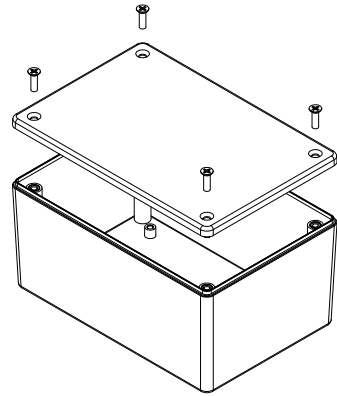
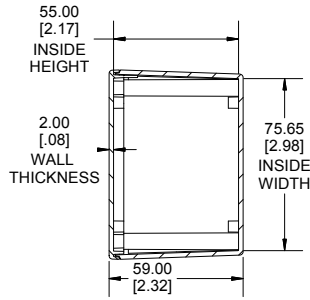
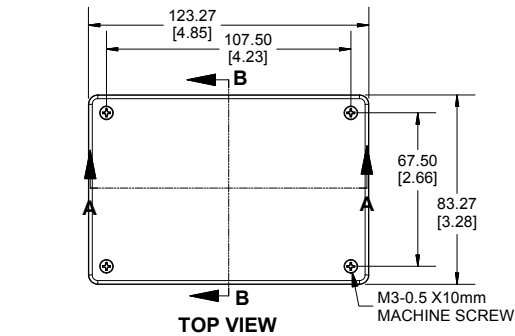

Enclosures can be Factory Modified (Milling, Drilling, Printing etc.)
Contact Factory mjm@hammondmfg.com for quotes
Solid models of this enclosure available in STEP or IGES.
(Part number and text placement/orientation on our products are subject to change,
we do not recommend using them as a locating reference for modification purposes)

NOTE	
Purchased assembly includes box, lid, 4 cover screws and installed brass inserts.	
Enclosure molded from FRABS UL 94-V0 Plastic.	
Other materials / colors available consult factory.	
Recommended Torque : (43-50) Oz.in / (30-35) dNm	

PART NUMBERS	
1591XXTBK Enclosure	
Black Textured Enclosure	1591XXTBK
Gray Textured Enclosure	1591XXTGY
ACCESSORIES	
Black Cover Screws [M3-0.5 X10mm]	1591MS100BK (Pkg 100)
Plated Cover Screws [M3-0.5 X10mm]	1591MS100 (Pkg 100)
P.C. Board Screws	1593ATS50 (Pkg 50)
#4 x 1/4" self-tapping (6.4mm)	1593ATS100 (Pkg 100)



**HAMMOND
MANUFACTURING.**
1591XXT

Dimensions:
mm
[inches]

www.hammondmfg.com