

Excellent Integrated System Limited

Stocking Distributor

Click to view price, real time Inventory, Delivery & Lifecycle Information:

[Molex Connector Corporation](#)

[09-57-1095](#)

For any questions, you can email us directly:

sales@integrated-circuit.com

NO. OF CKTS.	DIM. A MAX.	DIM. B REF.	DIM. C
2	(7.37)	(3.96)	(7.67)
	.290	.156	.302
3	(11.33)	(7.92)	(11.63)
	.446	.312	.458
4	(15.29)	(11.89)	(15.60)
	.602	.468	.614
5	(19.25)	(15.85)	(19.56)
	.758	.624	.770
6	(23.22)	(19.81)	(23.52)
	.914	.780	.926
7	(27.18)	(23.77)	(27.48)
	1.070	.936	1.080
8	(31.14)	(27.74)	(31.45)
	1.226	1.092	1.238
9	(35.10)	(31.70)	(35.41)
	1.382	1.248	1.394
10	(39.07)	(35.66)	(39.37)
	1.538	1.404	1.550
11	(43.03)	(39.62)	(43.33)
	1.694	1.560	1.706
12	(46.99)	(43.59)	(47.29)
	1.850	1.716	1.862
13	(50.95)	(47.55)	(51.26)
	2.006	1.872	2.018
14	(54.91)	(51.51)	(55.22)
	2.162	2.028	2.174
15	(58.88)	(55.47)	(59.18)
	2.318	2.184	2.330
16	(62.84)	(59.44)	(63.14)
	2.474	2.340	2.486
17	(66.80)	(63.40)	(67.11)
	2.630	2.496	2.642
18	(70.76)	(67.36)	(71.07)
	2.786	2.652	2.798
19	(74.65)	(71.32)	(74.96)
	2.939	2.808	2.951
20	(78.61)	(75.29)	(78.92)
	3.095	2.964	3.107

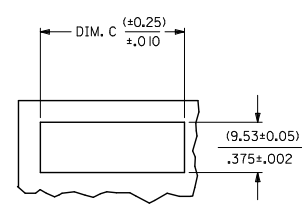
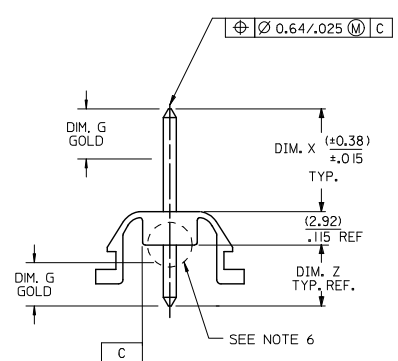

PANEL OPENNING
(1.57±.03) / .062±.001 THK.
PARTS MUST SNAP INTO ABOVE PCB

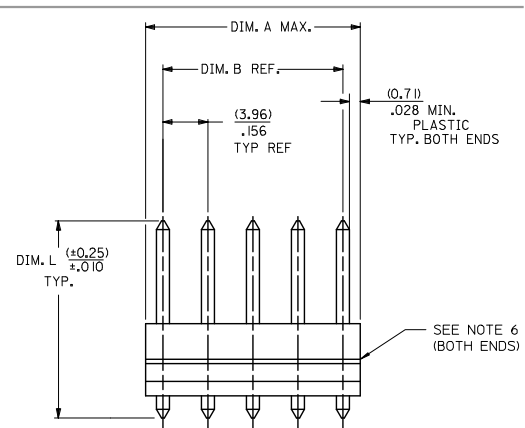

A-2220-N * * *
NO. OF CKTS. * * *
VERSION LETTER CHANGES WHEN PIN NO. OR PRESS DIM. CHANGES
PACKAGING BLANK = PER FK-2220-002
A = PER FK-44646-005
PLATING CODE SEE NOTE 2

- NOTES:
- MATERIAL: UNFILLED NYLON 6/6, UL94V-2, MOLDED NATURAL.
 - FINISH: SEE LEGEND
(197) - OVERALL REFLOWED MATTE TIN: 0.00152/0.00060 MIN. OVER 0.00127/0.00050 MIN. NICKEL
(502) - SELECT GOLD: 0.00051/0.00020 MIN. OVERALL NICKEL UNDERPLATE: 0.00127/0.00050 MIN.
 - PARTS CONFORM TO PRODUCT SPECIFICATION PS-08-50.
 - PACKAGING INFORMATION: SEE LEGEND.
 - PIN PUSHOUT FORCE: PRIOR TO SOLDERING, A 3 POUND MINIMUM FORCE (IN EITHER DIRECTION) SHALL BE REQUIRED TO PUSH THE PIN OUT OF THE HEADER.
 - THIS PART CONFORMS TO CLASS C REQUIREMENTS OF COSMETIC SPECIFICATION PH-45499-002. BURRS OR PROTRUSIONS ON HOUSING ARE ALLOWED IN PIN INSERTION AREA AND ON ENDS OF PART IF WITHIN DIMENSION A.

ADD NOTE 6 EC NO: UCP2015-1310 2017/10/02 DRAWN BY: DRW/KRIPPER 2017/10/02 CHKD/SUNSEK 2017/10/09 APPR/SMITH	QUALITY SYMBOLS ▽=0 ▽=1 ▽=0	GENERAL TOLERANCES (UNLESS SPECIFIED)		DIMENSION STYLE		SCALE	DESIGN UNITS	THIRD ANGLE PROJECTION
		mm	INCH	MM/IN	---	INCH	☉	
4 PLACES ± --- ± ---		DRAWN BY: KSS		DATE: 1984/10/30		TITLE: WAFER ASSEMBLY CHASSIS MOUNT, KK 2220 SERIES DWG. molex DOCUMENT NO. SDA-2220 SHEET NO. 1 OF 2		
3 PLACES ± --- ± ---		CHECKED BY: DMS		DATE: 1984/10/30				
2 PLACES ± --- ± ---		APPROVED BY: FSMITH		DATE: 2012/01/06				
1 PLACE ± --- ± ---		MATERIAL NO.		00000000				
0 PLACE ± --- ± ---		ANGULAR ±1/2°		SEE CHART				
DRAFT WHERE APPLICABLE MUST REMAIN WITHIN DIMENSIONS		THIS DRAWING CONTAINS INFORMATION THAT IS PROPRIETARY TO MOLEX INCORPORATED AND SHOULD NOT BE USED WITHOUT WRITTEN PERMISSION						

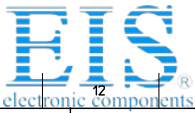

ENG. NO.	PIN NO.	DIM. L	DIM. X	DIM. Z	DIM. G TYP BOTH ENDS
A-2220-NA197	43294-0832	(35.05) 1.380	(16.00) .630	(16.13) .635	N/A
A-2220-NA502	43294-0833	(35.05) 1.380	(16.00) .630	(16.13) .635	(6.85) .270
A-2220-NAB502	43294-1100	(42.42) 1.670	(16.89) .665	(22.61) .890	(7.62) .300
A-2220-NB197	43294-1147	(44.45) 1.750	(18.24) .718	(23.29) .917	N/A

A-2220-NA197		A-2220-NA502		A-2220-NAB502		A-2220-NB197	
PART NO.	ENG. NO.	PART NO.	ENG. NO.	PART NO.	ENG. NO.	PART NO.	ENG. NO.
09-57-1025	A-2220-2A197	09-78-1021	A-2220-2A502		A-2220-2AB502	09-57-1026	A-2220-2B197
09-57-1035	A-2220-3A197	09-78-1031	A-2220-3A502		A-2220-3AB502	09-57-1036	A-2220-3B197
09-57-1045	A-2220-4A197	09-78-1041	A-2220-4A502		A-2220-4AB502	09-57-1046	A-2220-4B197
09-57-1055	A-2220-5A197	09-78-1051	A-2220-5A502		A-2220-5AB502	09-57-1056	A-2220-5B197
09-57-1065	A-2220-6A197	09-78-1061	A-2220-6A502	09-78-1067	A-2220-6AB502	09-57-1066	A-2220-6B197
09-57-1075	A-2220-7A197	09-78-1071	A-2220-7A502		A-2220-7AB502	09-57-1076	A-2220-7B197
09-57-1085	A-2220-8A197	09-78-1081	A-2220-8A502	09-78-1087	A-2220-8AB502	09-57-1086	A-2220-8B197
09-57-1095	A-2220-9A197	09-78-1091	A-2220-9A502		A-2220-9AB502	09-57-1096	A-2220-9B197
09-57-1105	A-2220-10A197	09-78-1101	A-2220-10A502	09-78-1107	A-2220-10AB502	09-57-1106	A-2220-10B197
09-57-1115	A-2220-11A197	09-78-1111	A-2220-11A502		A-2220-11AB502	09-57-1116	A-2220-11B197
09-57-1125	A-2220-12A197	09-78-1121	A-2220-12A502	09-78-1127	A-2220-12AB502	09-57-1126	A-2220-12B197
09-57-1135	A-2220-13A197	09-78-1131	A-2220-13A502		A-2220-13AB502	09-57-1136	A-2220-13B197
09-57-1145	A-2220-14A197	09-78-1141	A-2220-14A502		A-2220-14AB502	09-57-1146	A-2220-14B197
09-57-1155	A-2220-15A197	09-78-1151	A-2220-15A502	09-78-1157	A-2220-15AB502	09-57-1156	A-2220-15B197
09-57-1165	A-2220-16A197	09-78-1161	A-2220-16A502		A-2220-16AB502	09-57-1166	A-2220-16B197
09-57-1175	A-2220-17A197	09-78-1171	A-2220-17A502		A-2220-17AB502	09-57-1176	A-2220-17B197
09-57-1185	A-2220-18A197	09-78-1181	A-2220-18A502		A-2220-18AB502	09-57-1186	A-2220-18B197

ADD PN CHART EC NO: UCP2015-1510 DRAWN BY: 2012/10/02 CHKD BY: 2012/10/02 APPROVED BY: 2012/10/09 S1	QUALITY SYMBOLS 	GENERAL TOLERANCES (UNLESS SPECIFIED)		DIMENSION STYLE MM/IN		SCALE ---	DESIGN UNITS INCH	THIRD ANGLE PROJECTION	
		4 PLACES ± --- ± --- 3 PLACES ± --- ± --- 2 PLACES ± --- ± --- 1 PLACE ± --- ± --- 0 PLACE ± --- ± ---	mm INCH --- --- --- --- --- --- --- ---	DRAWN BY KSS	DATE 1984/10/30	TITLE WAFER ASSEMBLY CHASSIS MOUNT, KK 2220 SERIES DWG.			
		ANGULAR ±1/2°		CHECKED BY DMS	DATE 1984/10/30				
		DRAFT WHERE APPLICABLE MUST REMAIN WITHIN DIMENSIONS		APPROVED BY F SMITH	DATE 2012/01/06	MATERIAL NO. SEE CHART	DOCUMENT NO. SDA-2220	SHEET NO. 2 OF 2	THIS DRAWING CONTAINS INFORMATION THAT IS PROPRIETARY TO MOLEX INCORPORATED AND SHOULD NOT BE USED WITHOUT WRITTEN PERMISSION