

Excellent Integrated System Limited

Stocking Distributor

Click to view price, real time Inventory, Delivery & Lifecycle Information:

[Fairchild Semiconductor](#)
[DM74ALS14M](#)

For any questions, you can email us directly:

sales@integrated-circuit.com



March 1986
Revised February 2000

DM74ALS14 Hex Inverter with Schmitt Trigger Inputs

General Description

This device contains six independent gates, each of which performs the logic INVERT function. Each input has hysteresis which increases the noise immunity and transforms a slowly changing input signal to a fast changing, jitter-free output.

Features

- Input hysteresis
- Low output noise generation
- High input noise immunity
- Switching specification at 50 pF
- Switching specifications guaranteed over full temperature and V_{CC} range
- Advanced oxide-isolated, ion-implanted Schottky TTL process
- Functionally and pin-for-pin compatible with Schottky and low power Schottky TTL counterparts
- Improved AC performance over low power Schottky counterpart

Ordering Code:

Order Number	Package Number	Package Description
DM74ALS14M	M14A	14-Lead Small Outline Integrated Circuit (SOIC), JEDEC MS-012, 0.150 Narrow
DM74ALS14SJ	M14D	14-Lead Small Outline Package (SOP), EIAJ TYPE II, 5.3mm Wide
DM74ALS14N	N14A	14-Lead Plastic Dual-In-Line Package (PDIP), JEDEC MS-001, 0.300 Wide

Devices also available in Tape and Reel. Specify by appending the suffix letter "X" to the ordering code.

Connection Diagram

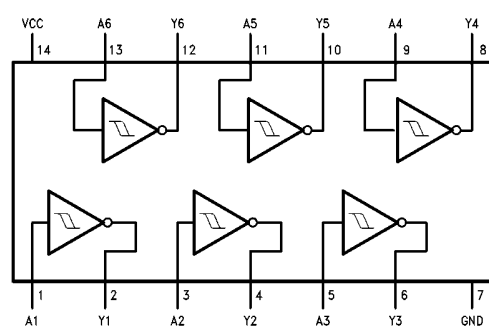

Function Table

$$Y = \bar{A}$$

Input A	Output Y
L	H
H	L

H = HIGH Logic Level
L = LOW Logic Level

DM74ALS14

Absolute Maximum Ratings (Note 1)

Supply Voltage	7V
Input Voltage	7V
Storage Temperature Range	-65°C to +150°C
Operating Free Air Temperature Range	0°C to +70°C
Typical θ_{JA}	
N Package	78.5°C/W
M Package	109.0°C/W

Note 1: The "Absolute Maximum Ratings" are those values beyond which the safety of the device cannot be guaranteed. The device should not be operated at these limits. The parametric values defined in the Electrical Characteristics tables are not guaranteed at the absolute maximum ratings. The "Recommended Operating Conditions" table will define the conditions for actual device operation.

Recommended Operating Conditions

Symbol	Parameter	Min	Nom	Max	Units	
V_{CC}	Supply Voltage	4.5	5	5.5	V	
V_{T+}	Positive-Going Input Threshold Voltage	$V_{CC} = \text{Min to Max}$	1.4		2	V
		$V_{CC} = 5V$	1.55		1.85	
V_{T-}	Negative-Going Input Threshold Voltage	$V_{CC} = \text{Min to Max}$	0.75		1.2	V
		$V_{CC} = 5V$	0.85		1.1	
HYS	Input Hysteresis	$V_{CC} = \text{Min to Max}$	0.5			V
		$V_{CC} = 5V$	0.6			
I_{OH}	HIGH Level Output Current			-0.4	mA	
I_{OL}	LOW Level Output Current			8	mA	
T_A	Operating Free Air Temperature Range	0		70	°C	

Electrical Characteristics

over recommended free air temperature range (unless otherwise noted)

Symbol	Parameter	Test Conditions	Min	Typ	Max	Units
V_{IK}	Input Clamp Voltage	$V_{CC} = \text{Min}, I_I = -18 \text{ mA}$			-1.5	V
V_{OH}	HIGH Level Output Voltage	$V_{CC} = 4.5V \text{ to } 5.5V, I_{OH} = \text{Max}$	$V_{CC} - 2$			V
V_{OL}	LOW Level Output Voltage	$V_{CC} = \text{Min}$ $I_{OL} = 4 \text{ mA}$ $I_{OL} = 8 \text{ mA}$		0.25	0.4	V
				0.35	0.5	
I_{T+}	Input Current at Positive-Going Threshold Voltage	$V_{CC} = 5V, V_I = V_{T+}$			20	μA
I_{T-}	Input Current at Negative-Going Threshold Voltage	$V_{CC} = 5V, V_I = V_{T-}$			-100	μA
I_I	Input Current at Maximum Input Voltage	$V_{CC} = \text{Max}, V_I = 7V$			100	μA
I_{IH}	HIGH Level Input Current	$V_{CC} = \text{Max}, V_I = 2.7V$			20	μA
I_{IL}	LOW Level Input Current	$V_{CC} = \text{Max}, V_I = 0.4V$			-100	μA
I_O	Output Drive Current	$V_{CC} = \text{Max}, V_O = 2.25V$	-30		-112	mA
I_{CCH}	Supply Current with Outputs HIGH	$V_{CC} = \text{Max}$			12	mA
I_{CCL}	Supply Current with Outputs LOW	$V_{CC} = \text{Max}$			12	mA
V_{OLP}	Quiet Output Maximum	$V_{CC} = 5.0V, T_A = 25^\circ\text{C}$ (Figures 1, 2); (Note 2)(Note 3)	0.16			V
	Dynamic V_{OL}					
V_{OLV}	Quiet Output Minimum	$V_{CC} = 5.0V, T_A = 25^\circ\text{C}$ (Figures 1, 2); (Note 2)(Note 3)	-0.27			V
	Dynamic V_{OL}					
V_{IHD}	Minimum HIGH Level	$V_{CC} = 5.0V, T_A = 25^\circ\text{C}$ (Note 2)(Note 4)	1.44			V
	Dynamic Input Voltage					
V_{ILD}	Maximum LOW Level	$V_{CC} = 5.0V, T_A = 25^\circ\text{C}$ (Note 2)(Note 4)	1.15			V
	Dynamic Input Voltage					

Note 2: Plastic DIP package.

Note 3: n = number of device outputs, n - 1 outputs switching, each driven 0V to 3V one output @ GND.

Note 4: n = number of device outputs, n outputs switching, n - 1 inputs switching 0V to 3V. Input under test switching 3V to threshold (V_{ILD}); 0V to threshold (V_{IHD}); f = 1 MHz.

Switching Characteristics over recommended operating free air temperature range

Symbol	Parameter	Conditions	Min	Max	Units
t_{PLH}	Propagation Delay Time LOW-to-HIGH Level Output	$V_{CC} = 4.5V$ to $5.5V$	2	12	ns
t_{PHL}	Propagation Delay Time HIGH-to-LOW Level Output	$R_L = 500\Omega$, $C_L = 50$ pF	2	10	ns

ALS Noise Characteristics

The setup of a noise characteristics measurement is critical to the accuracy and repeatability of the tests. The following is a brief description of the setup used to measure the noise characteristics of ALS.

Equipment:

- Word Generator
- Printed Circuit Board Test Fixture
- Dual Trace Oscilloscope

Procedure:

1. Verify Test Fixture Loading: Standard Load 50 pF, 500Ω .
2. Deskew the word generator so that no two channels have greater than 150 ps skew between them. This requires that the oscilloscope be deskewed first. Swap out the channels that have more than 150 ps of skew until all channels being used are within 150 ps. It is important to deskew the word generator channels before testing. This will ensure that the outputs switch simultaneously.
3. Terminate all inputs and outputs to ensure proper loading of the outputs and that the input levels are at the correct voltage.
4. Set V_{CC} to $5.0V$.
5. Set the word generator to toggle all but one output at a frequency of 1 MHz. Greater frequencies will increase DUT heating and affect the results of the measurement.
6. Set the word generator input levels at $0V$ LOW and $3V$ HIGH. Verify levels with a digital volt meter.

V_{OLP}/V_{OLV} and V_{OHP}/V_{OHV} :

- Determine the quiet output pin that demonstrates the greatest noise levels. The worst case pin will usually be the furthest from the ground pin. Monitor the output voltages using a 50Ω coaxial cable plugged into a standard SMB type connector on the test fixture. Do not use an active FET probe.

- Verify that the GND reference recorded on the oscilloscope has not drifted to ensure the accuracy and repeatability of the measurements.

V_{ILD} and V_{IHD} :

- Monitor one of the switching outputs using a 50Ω coaxial cable plugged into a standard SMB type connector on the test fixture. Do not use an active FET probe.
- First increase the input LOW voltage level, V_{IL} , until the output begins to oscillate. Oscillation is defined as noise on the output LOW level that exceeds V_{IL} limits, or on output HIGH levels that exceed V_{IH} limits. The input LOW voltage level at which oscillation occurs is defined as V_{ILD} .
- Next decrease the input HIGH voltage level on the word generator, V_{IH} until the output begins to oscillate. Oscillation is defined as noise on the output LOW level that exceeds V_{IL} limits, or on output HIGH levels that exceed V_{IH} limits. The input HIGH voltage level at which oscillation occurs is defined as V_{IHD} .
- Verify that the GND reference recorded on the oscilloscope has not drifted to ensure the accuracy and repeatability of the measurements.

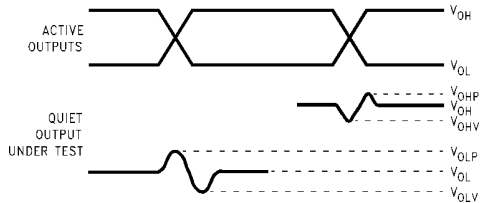

V_{OHV} and V_{OHP} are measured with respect to V_{OH} reference. V_{OLV} and V_{OLP} are measured with respect to ground reference.

Input pulses have the following characteristics: $f = 1$ MHz, $t_r = 3$ ns, $t_f = 3$ ns, skew < 150 ps.

FIGURE 1. Quiet Output Noise Voltage Waveforms

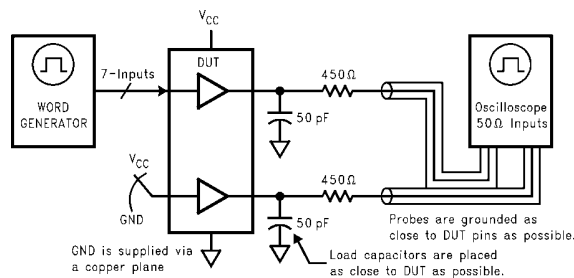
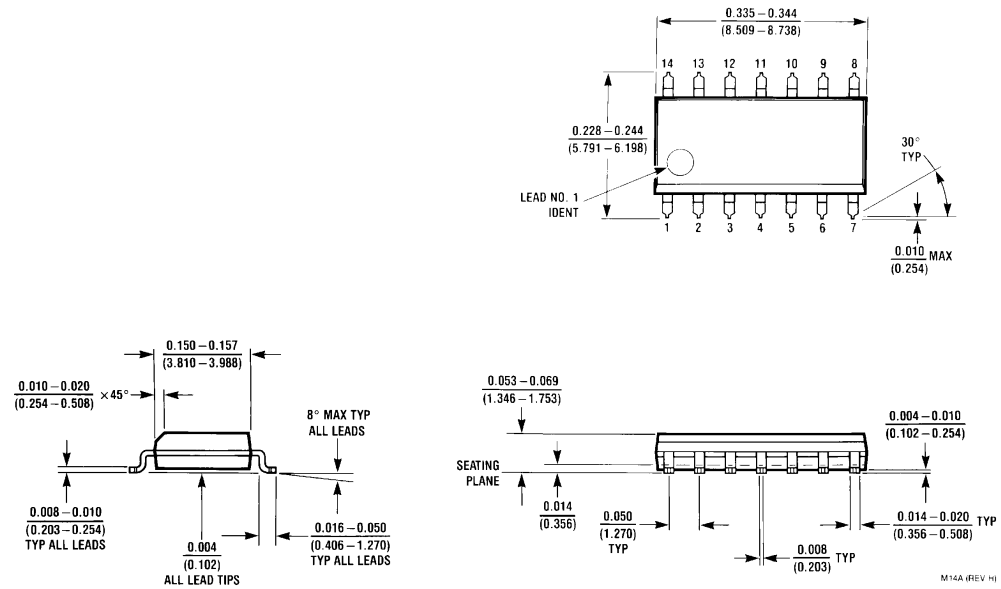

FIGURE 2. Simultaneous Switching Test Circuit

DM74ALS14

Physical Dimensions inches (millimeters) unless otherwise noted



14-Lead Small Outline Integrated Circuit (SOIC), JEDEC MS-012, 0.150 Narrow
 Package Number M14A

Physical Dimensions inches (millimeters) unless otherwise noted (Continued)

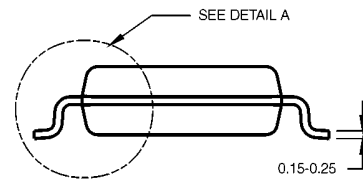
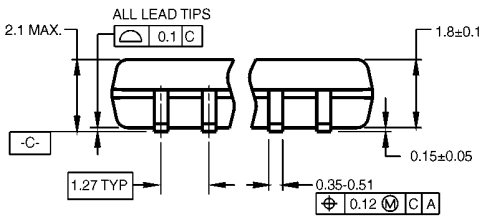
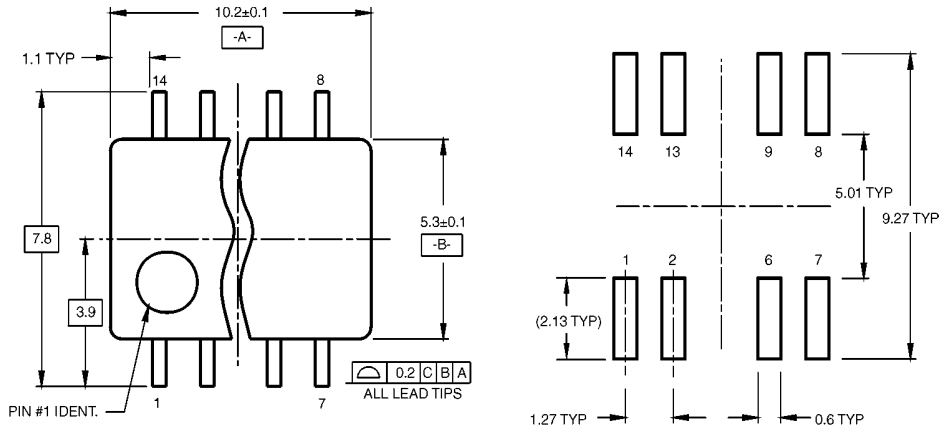

DIMENSIONS ARE IN MILLIMETERS

NOTES:

- A. CONFORMS TO EIAJ EDR-7320 REGISTRATION, ESTABLISHED IN DECEMBER, 1998.
- B. DIMENSIONS ARE IN MILLIMETERS.
- C. DIMENSIONS ARE EXCLUSIVE OF BURRS, MOLD FLASH, AND TIE BAR EXTRUSIONS.

M14DRRevB1

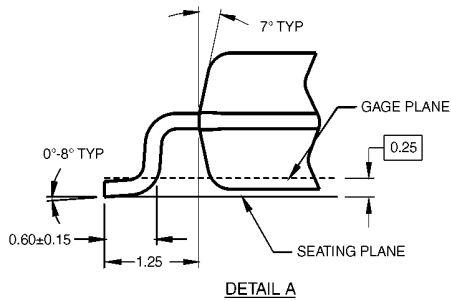

**14-Lead Small Outline Package (SOP), EIAJ TYPE II, 5.3mm Wide
 Package Number M14D**

DM74ALS14 Hex Inverter with Schmitt Trigger Inputs

Physical Dimensions inches (millimeters) unless otherwise noted (Continued)

OPTION 1

OPTION 2

14-Lead Plastic Dual-In-Line Package (PDIP), JEDEC MS-001, 0.300 Wide Package Number N14A

Fairchild does not assume any responsibility for use of any circuitry described, no circuit patent licenses are implied and Fairchild reserves the right at any time without notice to change said circuitry and specifications.

LIFE SUPPORT POLICY

FAIRCHILD'S PRODUCTS ARE NOT AUTHORIZED FOR USE AS CRITICAL COMPONENTS IN LIFE SUPPORT DEVICES OR SYSTEMS WITHOUT THE EXPRESS WRITTEN APPROVAL OF THE PRESIDENT OF FAIRCHILD SEMICONDUCTOR CORPORATION. As used herein:

1. Life support devices or systems are devices or systems which, (a) are intended for surgical implant into the body, or (b) support or sustain life, and (c) whose failure to perform when properly used in accordance with instructions for use provided in the labeling, can be reasonably expected to result in a significant injury to the user.
2. A critical component in any component of a life support device or system whose failure to perform can be reasonably expected to cause the failure of the life support device or system, or to affect its safety or effectiveness.

www.fairchildsemi.com