

Excellent Integrated System Limited

Stocking Distributor

Click to view price, real time Inventory, Delivery & Lifecycle Information:

[Phyton Inc.](#)
[AE-ISP-U1](#)

For any questions, you can email us directly:
sales@integrated-circuit.com

AE-ISP-U1



DIP28/BH-10 universal adapter for in system programming.

Click the programmer model below to get an appropriate list of the devices supported by the adapter:

- [ChipProg+](#)
- [ChipProg-40](#)
- [ChipProg-48, ChipProg-G4](#)

Adapter Wiring Diagram:

DIP-28	BH-10	74AHC126	74AHC126	C1, 0.1uF
1,23	1	3		
2	3	6		
3	5	8		
4	7			
5,14	9	7	1,2,7	1
6		2		
7		1		
8		5		
9		14	14	2
10		9		
11		10		
12		12		
13		13		
15		4		

16			5	
17			4	
18			9	
19			10	
20			12	
21			13	
22				
24	10		6	
25	8			
26	6		8	
27	4		11	
28	2	11		

- [AE-ISP-U1 connection for the 24xx devices](#)
- [AE-ISP-U1 connection for the 25xxx devices](#)
- [AE-ISP-U1 connection for the 93xx devices](#)
- [AE-ISP-U1 connection for the Atmel AT45xxx devices](#)
- [AE-ISP-U1 connection for the Atmel AT89LP21x devices](#)
- [AE-ISP-U1 connection for the Atmel AT90/ATS89S/ATtiny/ATmega devices](#)
- [AE-ISP-U1 connection for the Atmel ATTINY10 devices in TPI Mode](#)
- [AE-ISP-U1 connection for the Atmel ATXMega devices in PDI Mode for ChipProg-40](#)
- [AE-ISP-U1 connection for the Atmel ATXMega devices in PDI Mode for ChipProg-48](#)
- [AE-ISP-U1 connection for the Atmel ATmega103/128/1281/2561/64 AT90CAN128 devices](#)
- [AE-ISP-U1 connection for the Atmel ATtiny devices in the High-Voltage Mode](#)
- [AE-ISP-U1 connection for the Cypress CY8C2xxxx devices](#)
- [AE-ISP-U1 connection for the Dallas iButton](#)
- [AE-ISP-U1 connection for the Dallas/Maxim DS89C420/430/440/450 devices](#)
- [AE-ISP-U1 connection for the Freescale HCS08, HCS12 devices](#)
- [AE-ISP-U1 connection for the Freescale MC68HC908JK1 devices](#)
- [AE-ISP-U1 connection for the Infineon XC886/888CLM, XE164/167 devices](#)
- [AE-ISP-U1 connection for the Microchip HCS101/HCS201/HCS360/HCS361/HCS362 devices](#)
- [AE-ISP-U1 connection for the Microchip HCS200/HCS300/HCS301/HCS320 devices](#)
- [AE-ISP-U1 connection for the Microchip MC250XX devices](#)
- [AE-ISP-U1 connection for the Microchip PIC10/PIC12 devices](#)
- [AE-ISP-U1 connection for the Microchip PIC16/PIC18 devices](#)
- [AE-ISP-U1 connection for the Microchip PIC16C505 devices](#)
- [AE-ISP-U1 connection for the Microchip PIC16Fxxx 14..20 pins devices](#)
- [AE-ISP-U1 connection for the Microchip PIC17xxx devices](#)
- [AE-ISP-U1 connection for the Microchip PIC18FxxJ devices](#)
- [AE-ISP-U1 connection for the Microchip PIC24 devices](#)
- [AE-ISP-U1 connection for the Microchip dsPIC30F devices](#)
- [AE-ISP-U1 connection for the Microchip dsPIC33FJ devices](#)
- [AE-ISP-U1 connection for the NEC UPD78F9210, UPD78F9211 devices](#)
- [AE-ISP-U1 connection for the NVM3060 device](#)
- [AE-ISP-U1 connection for the NXP/Philips LPC2100/LPC2200 devices in the ISP Mode](#)
- [AE-ISP-U1 connection for the NXP/Philips LPC2300/LPC2400 devices in the ISP Mode](#)
- [AE-ISP-U1 connection for the NXP/Philips P89LPC9xx devices in the ISP Mode](#)
- [AE-ISP-U1 connection for the NXP/Philips P89xxx devices in the ICP Mode](#)
- [AE-ISP-U1 connection for the Nordic microcontrollers](#)

- [AE-ISP-U1 connection for the SST SST26xx](#)
- [AE-ISP-U1 connection for the STMicroelectronics M35080](#)
- [AE-ISP-U1 connection for the STMicroelectronics M45Pxxx devices](#)
- [AE-ISP-U1 connection for the STMicroelectronics STM32 devices in the BootLoader \(BL\) Mode](#)
- [AE-ISP-U1 connection for the TI MSP430 devices in the BSL Mode with the TEST pin](#)
- [AE-ISP-U1 connection for the TI MSP430F13x/14x devices in the BSL Mode](#)
- [AE-ISP-U1 connection for the TI MSP430F4xx devices in the BSL Mode](#)
- [AE-ISP-U1 connection for the Zilog Z8F devices](#)

AE-ISP-U1 connection for the 24xx devices

Click the programmer model below to get an appropriate list of the devices supported by the adapter:

- [ChipProg+](#)
- [ChipProg-40](#)
- [ChipProg-48, ChipProg-G4](#)

Recommended connection:

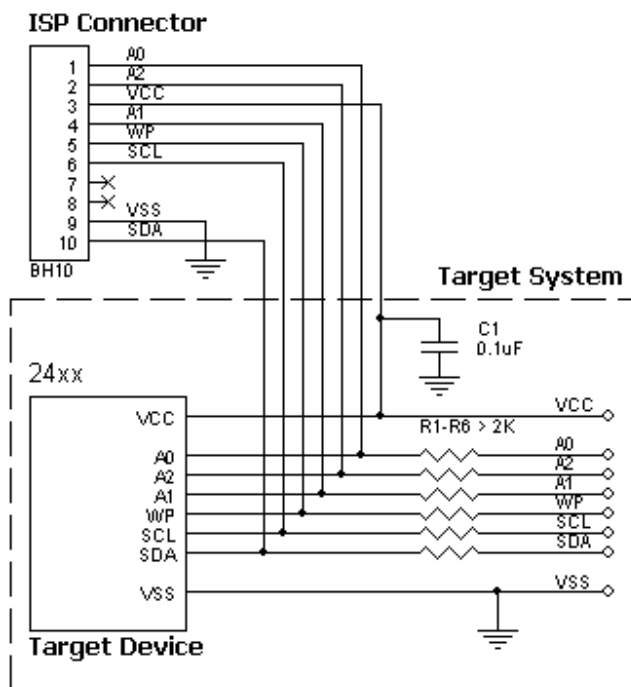

Powering the target device:

There are two alternative options for powering the targets:

1. The target gets power from the programmer (Vdd). This is possible only if the target does not consume too much energy. A capacity of the target power circuitry should not exceed 50 uF.
2. The target gets power from a built-in or external power supply. In this case the power output from the programmer should not be connected with the target. The target system should be tolerant to applying logical signals with the voltage levels exceeding the voltages on the target.

NOTE! It is strictly prohibited to power the target from both the programmer and built-in or external power supply simultaneously.

Isolating resistors:

Purpose of the R1..R6 resistors is to isolate the

programmed chip from rest of target system. Recommended value of resistors R1..R6 is 2k or more. You can also use jumpers instead of the resistors.

ISP characteristics:

1. Programmer's output capability:
 - 1.1 Vcc - 80 mA;
 - 1.2 Vpp - 50 mA;
 - 1.3 logical pins - 5 mA.

2. The cable length should be less than one foot.

Table of connections of the adapter output socket to the device pins:

Adapter Output connector, BH-10	Target Device 24xx
1	1
3	8
5	7
7	-
9	4
10	5
8	-
6	6
4	2
2	3

AE-ISP-U1 connection for the 25xxx devices

Click the programmer model below to get an appropriate list of the devices supported by the adapter:

- [ChipProg+](#)
- [ChipProg-40](#)
- [ChipProg-48, ChipProg-G4](#)

Recommended connection:

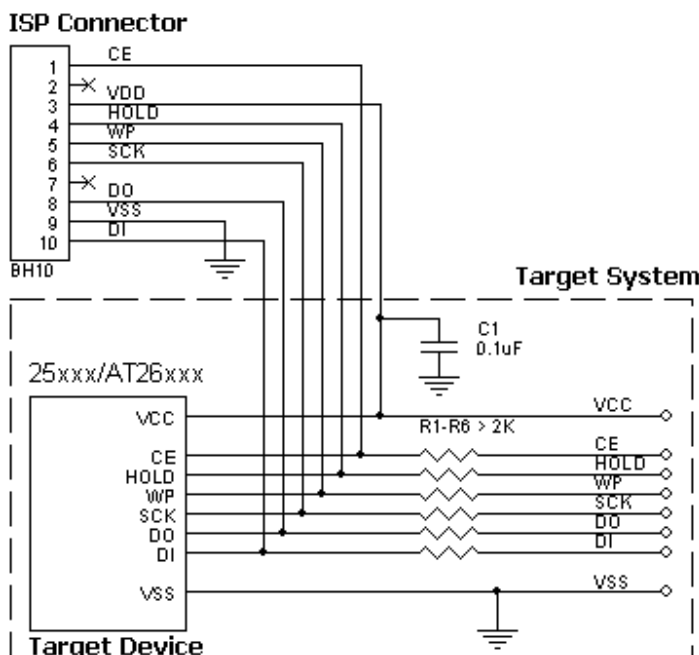

Powering the target device:

There are two alternative options for powering the targets:

1. The target gets power from the programmer (Vdd). This is possible only if the target does not consume too much energy. A capacity of the target power circuitry should not exceed 50 uF.
 2. The target gets power from a built-in or external power supply. In this case the power output from the programmer should not be connected with the target. The target system should be tolerant to applying logical signals with the voltage levels exceeding the voltages on the target.
- NOTE! It is strictly prohibited to power the target from both the programmer and built-

in or external power supply simultaneously.

Isolating resistors:

Purpose of the R1..R6 resistors is to isolate the programmed chip from rest of target system. Recommended value of resistors R1..R6 is 2k or more. You can also use jumpers instead of the resistors.

ISP characteristics:

1. Programmer's output capability:
 - 1.1 Vcc - 80 mA;
 - 1.2 Vpp - 50 mA;
 - 1.3 logical pins - 5 mA.
2. The cable length should be less then one foot.

Table of connections of the adapter output socket to the device pins:

Adapter Output connector, BH-10	Target Device AT26xxx	Target Device 25xxx 8 pins package	Target Device 25xxx 16 pins package
1	1	1	7
3	8	8	2
5	3	3	9
7	-	-	-
9	4	4	10
10	5	5	15
8	2	2	8
6	6	6	16
4	7	7	1
2	-	-	-

AE-ISP-U1 connection for the 93xx devices

Click the programmer model below to get an appropriate list of the devices supported by the adapter:

- [ChipProg+](#)
- [ChipProg-40](#)
- [ChipProg-48, ChipProg-G4](#)

Recommended connection:

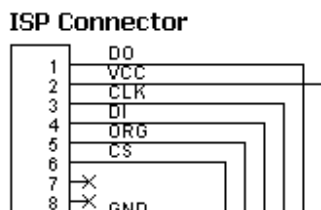

Powering the target device:

There are two alternative options for powering the targets:

1. The target gets power from the programmer

(Vdd). This is possible only if the target does not consume too much energy. A capacity of the target power circuitry should not exceed 50 uF.

2. The target gets power from a built-in or external power supply. In this case the power output from the programmer should not be connected with the target. The target system should be tolerant to applying logical signals with the voltage levels exceeding the voltages on the target.

NOTE! It is strictly prohibited to power the target from both the programmer and built-in or external power supply simultaneously.

Isolating resistors:

Purpose of the R1..R6 resistors is to isolate the programmed chip from rest of target system. Recommended value of resistors R1..R6 is 2k or more. You can also use jumpers instead of the resistors.

ISP characteristics:

1. Programmer's output capability:
 - 1.1 Vcc - 80 mA;
 - 1.2 Vpp - 50 mA;
 - 1.3 logical pins - 5 mA.
2. The cable length should be less then one foot.

Table of connections of the adapter output socket to the device pins:

Adapter Output connector, BH-10	Target Device 93xx
1	DO
3	CLK
5	ORG*
7	-
9	GND
10	PE*
8	-
6	CS
4	DI
2	Vcc

* Must be connected if there is no connection in a system.

AE-ISP-U1 connection for the Atmel AT45xxx devices

Click the programmer model below to get an appropriate list of the devices supported by the adapter:

- [ChipProg-40](#)

- [ChipProg-48, ChipProg-G4](#)

Recommended connection:

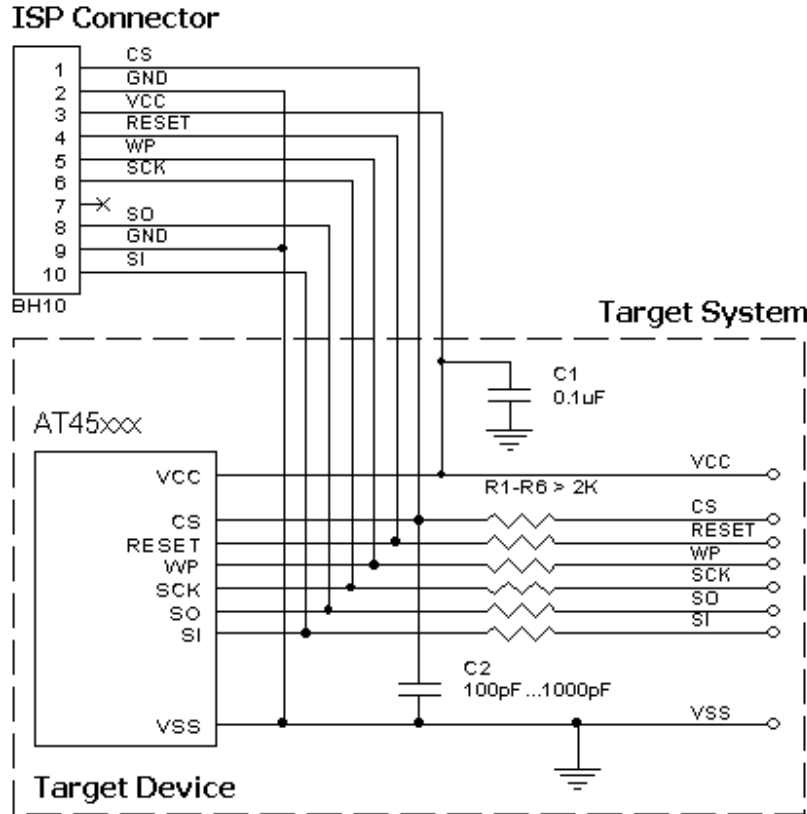

Powering the target device:

There are two alternative options for powering the targets:

1. The target gets power from the programmer (Vdd). This is possible only if the target does not consume too much energy. A capacity of the target power circuitry should not exceed 50 uF.
2. The target gets power from a built-in or external power supply. In this case the power output from the programmer should not be connected with the target. The target system should be tolerant to applying logical signals with the voltage levels exceeding the voltages on the target.

NOTE! It is strictly prohibited to power the target from both the programmer and built-in or external power supply simultaneously.

Isolating resistors:

Purpose of the R1..R6 resistors is to isolate the programmed chip from rest of target system. Recommended value of resistors R1..R6 is 2k or more. You can also use jumpers instead of the resistors.

ISP characteristics:

1. Programmer's output capability:
 - 1.1 Vcc - 80 mA;
 - 1.2 Vpp - 50 mA;
 - 1.3 logical pins - 5 mA.
2. The cable length should be less than one foot.

Table of connections of the adapter output socket to the device pins:

Adapter Output connector, BH-10	Target Device AT45xxx
1	CS
3	VCC
5	WP
7	

9	GND
10	SI
8	SO
6	SCK
4	RESET
2	GND

AE-ISP-U1 connection for the Atmel AT89LP21x devices

Click the programmer model below to get an appropriate list of the devices supported by the adapter:

- [ChipProg+](#)
- [ChipProg-40](#)
- [ChipProg-48, ChipProg-G4](#)

Recommended connection:

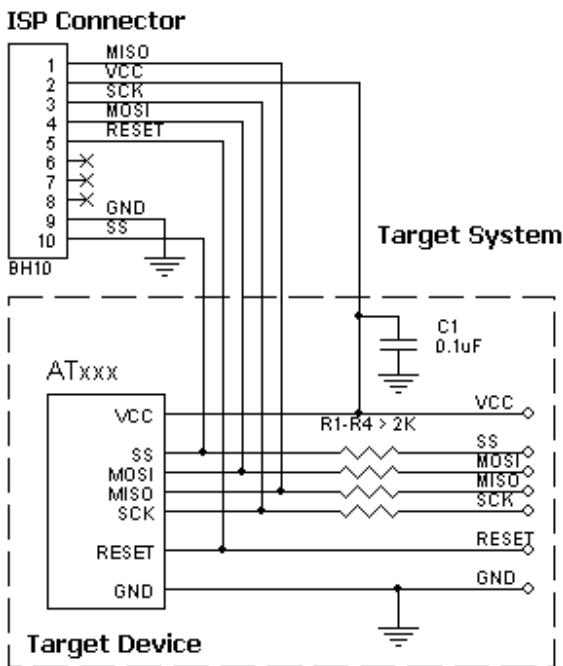

Powering the target device:

There are two alternative options for powering the targets:

1. The target gets power from the programmer (Vdd). This is possible only if the target does not consume too much energy. A capacity of the target power circuitry should not exceed 50 uF.
2. The target gets power from a built-in or external power supply. In this case the power output from the programmer should not be connected with the target. The target system should be tolerant to applying logical signals with the voltage levels exceeding the voltages on the target.

NOTE! It is strictly prohibited to power the target from both the programmer and built-in or external power supply simultaneously.

Isolating resistors:

Purpose of the R1..R4 resistors is to isolate the programmed chip from rest of target system. Recommended value of resistors R1..R4 is 2k or more. You can also use jumpers instead of the resistors.

ISP characteristics:

1. Programmer's output capability:
 - 1.1 Vcc - 80 mA;
 - 1.2 Vpp - 50 mA;
 - 1.3 logical pins - 5 mA.
2. The cable length should be less then one foot.

Table of connections of the adapter output socket to the device pins:

Adapter Output connector, BH-10	Target Device AT89LP21x
1	MISO
3	SCK
5	RESET
7	-
9	GND
10	SS
8	-
6	-
4	MOSI
2	Vcc

AE-ISP-U1 connection for the Atmel AT90/ATS89S/ATtiny/ATmega devices

Click the programmer model below to get an appropriate list of the devices supported by the adapter:

- [ChipProg+](#)
- [ChipProg-40](#)
- [ChipProg-48, ChipProg-G4](#)

Recommended connection:

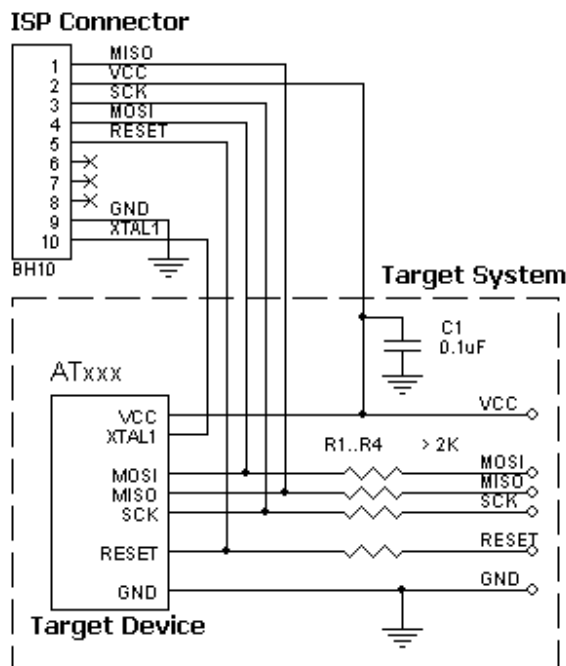

Powering the target device:

There are two alternative options for powering the targets:

1. The target gets power from the programmer (Vdd). This is possible only if the target does not consume too much energy. A capacity of the target power circuitry should not exceed 50 uF.

2. The target gets power from a built-in or external power supply. In this case the power output from the programmer should not be connected with the target. The target system should be tolerant to applying logical signals with the voltage levels exceeding the voltages on the target.

NOTE! It is strictly prohibited to power the target from both the programmer and built-in or external power supply simultaneously.

Isolating resistors:

Purpose of the R1..R4 resistors is to isolate the

programmed chip from rest of target system. Recommended value of resistors R1..R4 is 2k or more. You can also use jumpers instead of the resistors.

ISP characteristics:

1. Programmer's output capability:
 - 1.1 Vcc - 80 mA;
 - 1.2 Vpp - 50 mA;
 - 1.3 logical pins - 5 mA.
2. The cable length should be less than one foot.

Table of connections of the adapter output socket to the device pins:

Adapter Output connector, BH-10	Target Device AT90/AT89S (except AT90CAN128), ATtinyXX, ATmegaXXXX (except ATmega103, ATmega128, AT90CAN128, ATmega1281, ATmega2561, ATmega64)
1	MISO
3	SCK
5	RESET
7	-
9	GND
10	XTAL1*
8	-
6	-
4	MOSI
2	Vcc

* Must be connected if there is no external oscillator in system.

AE-ISP-U1 connection for the Atmel ATTINY10 devices in TPI Mode

Click the programmer model below to get an appropriate list of the devices supported by the adapter:

- [ChipProg-40](#)
- [ChipProg-48, ChipProg-G4](#)

Recommended connection:

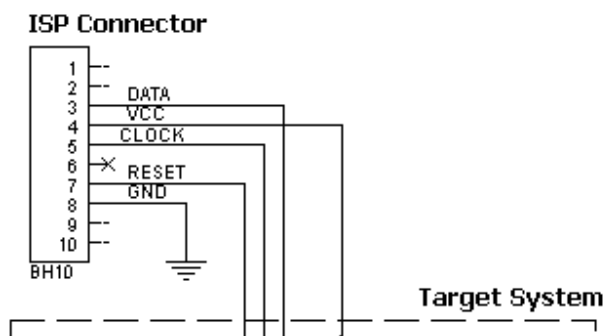

Powering the target device:

There are two alternative options for powering the targets:

1. The target gets power from the programmer (Vdd). This is possible only if the target does not consume too much energy. A capacity of the target power circuitry should not exceed 50 uF.
2. The target gets power from a built-in or external

power supply. In this case the power output from the programmer should not be connected with the target. The target system should be tolerant to applying logical signals with the voltage levels exceeding the voltages on the target.

NOTE! It is strictly prohibited to power the target from both the programmer and built-in or external power supply simultaneously.

Isolating resistors:

Purpose of the R1..R3 resistors is to isolate the programmed chip from rest of target system. Recommended value of resistors R1..R3 is 2k or more. You can also use jumpers instead of the resistors.

ISP characteristics:

1. Programmer's output capability:
 - 1.1 Vcc - 80 mA;
 - 1.2 Vpp - 50 mA;
 - 1.3 logical pins - 5 mA.
2. The cable length should be less than one foot.

Table of connections of the adapter output socket to the device pins:

Adapter Output connector, BH-10	ATTINY10
1	-
2	-
3	DATA
4	VCC
5	CLOCK
6	-
7	RESET
8	GND
9	-
10	-

AE-ISP-U1 connection for the Atmel ATXMega devices in PDI Mode for ChipProg-40

Click the programmer model below to get an appropriate list of the devices supported by the adapter:

- [ChipProg-40](#)

Recommended connection:

ISP Connector



Powering the target device:

There are two alternative options for powering

the targets:

1. The target gets power from the programmer (Vdd). This is possible only if the target does not consume too much energy. A capacity of the target power circuitry should not exceed 50 uF.
 2. The target gets power from a built-in or external power supply. In this case the power output from the programmer should not be connected with the target. The target system should be tolerant to applying logical signals with the voltage levels exceeding the voltages on the target.
- NOTE! It is strictly prohibited to power the target from both the programmer and built-in or external power supply simultaneously.

Isolating resistors:

Purpose of the R1..R2 resistors is to isolate the programmed chip from rest of target system. Recommended value of resistors R1..R2 is 2k or more. You can also use jumpers instead of the resistors.

ISP characteristics:

1. Programmer's output capability:
 - 1.1 Vcc - 80 mA;
 - 1.2 Vpp - 50 mA;
 - 1.3 logical pins - 5 mA.
2. The cable length should be less then one foot.

Table of connections of the adapter output socket to the device pins:

Adapter Output connector, BH-10	ATxMega
1	
2	
3	Data
4	Vcc
5	
6	
7	Clock
8	Gnd
9	-
10	-

AE-ISP-U1 connection for the Atmel ATXMega devices in PDI Mode for ChipProg-48

Click the programmer model below to get an appropriate list of the devices supported by the adapter:

- [ChipProg-48, ChipProg-G4](#)

Recommended connection:

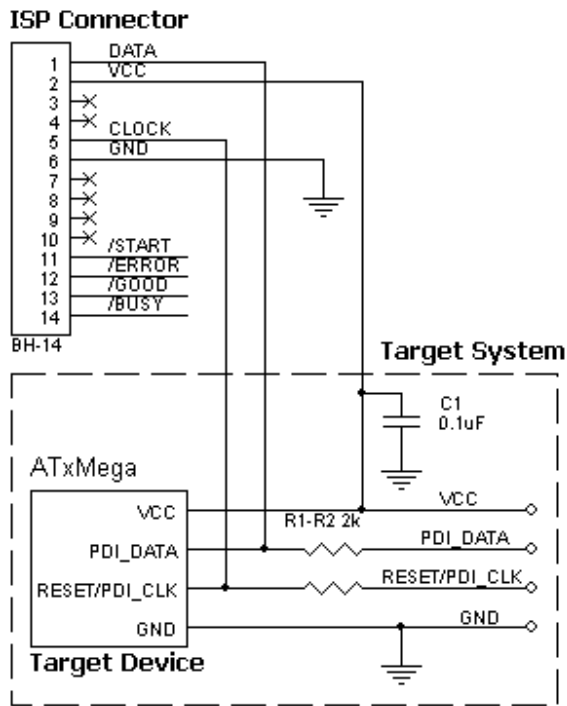

Recommended value of resistors R1..R2 is 2k or more. You can also use jumpers instead of the resistors.

ISP characteristics:

1. Programmer's output capability:
 - 1.1 Vcc - 80 mA;
 - 1.2 Vpp - 50 mA;
 - 1.3 logical pins - 5 mA.
2. The cable length should be less then one foot.

Table of connections of the adapter output socket to the device pins:

Adapter Output connector, BH-10	ATxMega
1	DATA
2	Vcc
3	-
4	-
5	CLOCK
6	GND
7	-
8	-
9	-
10	-

Powering the target device:

There are two alternative options for powering the targets:

1. The target gets power from the programmer (Vdd). This is possible only if the target does not consume too much energy. A capacity of the target power circuitry should not exceed 50 uF.
2. The target gets power from a built-in or external power supply. In this case the power output from the programmer should not be connected with the target. The target system should be tolerant to applying logical signals with the voltage levels exceeding the voltages on the target.

NOTE! It is strictly prohibited to power the target from both the programmer and built-in or external power supply simultaneously.

Isolating resistors:

Purpose of the R1..R2 resistors is to isolate the programmed chip from rest of target system.

AE-ISP-U1 connection for the Atmel ATmega103/128/1281/2561/64 AT90CAN128 devices

Click the programmer model below to get an appropriate list of the devices supported by the adapter:

- [ChipProg+](#)
- [ChipProg-40](#)
- [ChipProg-48, ChipProg-G4](#)

Recommended connection:

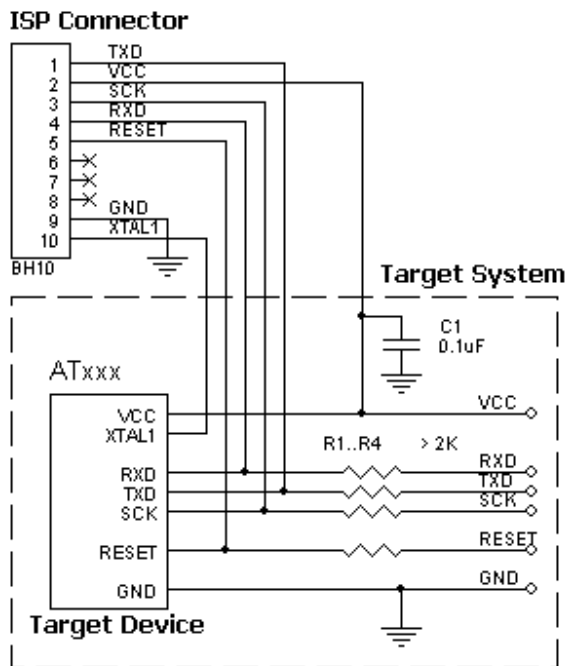

Powering the target device:

There are two alternative options for powering the targets:

1. The target gets power from the programmer (Vdd). This is possible only if the target does not consume too much energy. A capacity of the target power circuitry should not exceed 50 uF.
2. The target gets power from a built-in or external power supply. In this case the power output from the programmer should not be connected with the target. The target system should be tolerant to applying logical signals with the voltage levels exceeding the voltages on the target.

NOTE! It is strictly prohibited to power the target from both the programmer and built-in or external power supply simultaneously.

Isolating resistors:

Purpose of the R1..R4 resistors is to isolate the

programmed chip from rest of target system. Recommended value of resistors R1..R4 is 2k or more. You can also use jumpers instead of the resistors.

ISP characteristics:

1. Programmer's output capability:
 - 1.1 Vcc - 80 mA;
 - 1.2 Vpp - 50 mA;
 - 1.3 logical pins - 5 mA.
2. The cable length should be less then one foot.

Table of connections of the adapter output socket to the device pins:

Adapter Output connector, BH-10	Target Device ATmega103, ATmega128, AT90CAN128, ATMega1281, ATMega2561, ATMega64
1	TXD
3	SCK

5	RESET
7	-
9	GND
10	XTAL1*
8	-
6	-
4	RXD
2	Vcc

* Must be connected if there is no external oscillator in system.

AE-ISP-U1 connection for the Atmel ATtiny devices in the High-Voltage Mode

Click the programmer model below to get an appropriate list of the devices supported by the adapter:

- [ChipProg+](#)
- [ChipProg-40](#)
- [ChipProg-48, ChipProg-G4](#)

Recommended connection:

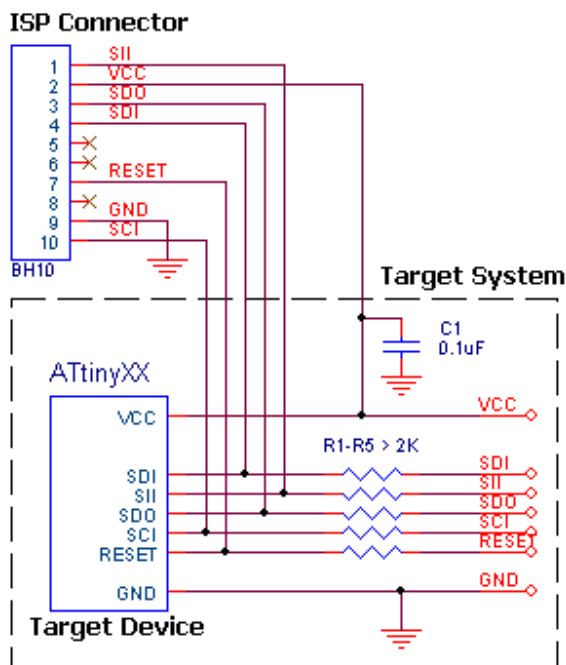

Powering the target device:

There are two alternative options for powering the targets:

1. The target gets power from the programmer (Vdd). This is possible only if the target does not consume too much energy. A capacity of the target power circuitry should not exceed 50 uF.
2. The target gets power from a built-in or external power supply. In this case the power output from the programmer should not be connected with the target. The target system should be tolerant to applying logical signals with the voltage levels exceeding the voltages on the target.

NOTE! It is strictly prohibited to power the target from both the programmer and built-in or external power supply simultaneously.

Isolating resistors:

Purpose of the R1..R5 resistors is to isolate the programmed chip from rest of target system.

Recommended value of resistors R1..R5 is 2k or more. You can also use jumpers instead of the resistors.

ISP characteristics:

1. Programmer's output capability:
 - 1.1 Vcc - 80 mA;
 - 1.2 Vpp - 50 mA;
 - 1.3 logical pins - 5 mA.
2. The cable length should be less than one foot.

Table of connections of the adapter output socket to the device pins:

Adapter Output connector, BH-10	Target Device ATtinyXX in High-Voltage Mode
1	PB1
3	PB2
5	-
7	PB5
9	GND
10	PB3
8	-
6	-
4	PB0
2	Vcc

AE-ISP-U1 connection for the Cypress CY8C2xxxx devices

Click the programmer model below to get an appropriate list of the devices supported by the adapter:

- [ChipProg+](#)
- [ChipProg-48, ChipProg-G4](#)

Recommended connection:

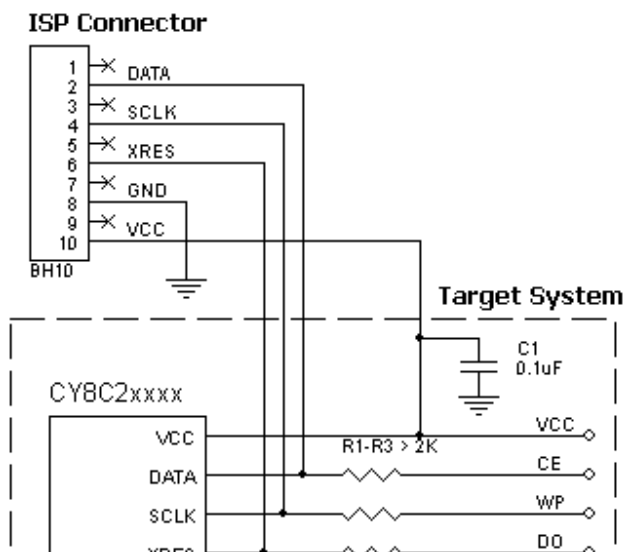

Powering the target device:

There are two alternative options for powering the targets:

1. The target gets power from the programmer (Vdd). This is possible only if the target does not consume too much energy. A capacity of the target power circuitry should not exceed 50 uF.
2. The target gets power from a built-in or external power supply. In this case the power output from the programmer should not be connected with the target. The target system should be tolerant to applying logical signals with the voltage levels exceeding the voltages on the target.

NOTE! It is strictly prohibited to power the target from both the programmer and built-in or external power supply simultaneously.

Isolating resistors:

Purpose of the R1..R3 resistors is to isolate the programmed chip from rest of target system. Recommended value of resistors R1..R3 is 2k or more. You can also use jumpers instead of the resistors.

ISP characteristics:

1. Programmer's output capability:
 - 1.1 Vcc - 80 mA;
 - 1.2 Vpp - 50 mA;
 - 1.3 logical pins - 5 mA.
2. The cable length should be less then one foot.

Table of connections of the adapter output socket to the device pins:

Adapter Output connector, BH-10	Target Device CY8C2xxxx
1	
2	DATA
3	
4	SCLK
5	
6	Xres
7	
8	GND
9	
10	Vcc

AE-ISP-U1 connection for the Dallas iButton

Click the programmer model below to get an appropriate list of the devices supported by the adapter:

- [ChipProg-40](#)
- [ChipProg-48, ChipProg-G4](#)

Recommended connection:

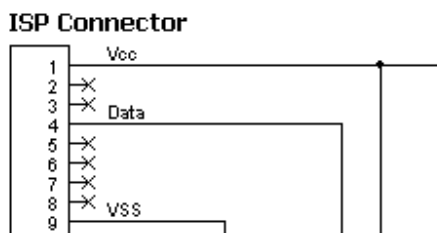

Powering the target device:

There are two alternative options for powering the targets:

1. The target gets power from the programmer (Vdd). This is possible only

if the target does not consume too much energy. A capacity of the target power circuitry should not exceed 50 uF.

2. The target gets power from a built-in or external power supply. In this case the power output from the programmer should not be connected with the target. The target system should be tolerant to applying logical signals with the voltage levels exceeding the voltages on the target.

NOTE! It is strictly prohibited to power the target from both the programmer and built-in or external power supply simultaneously.

Isolating resistors:

Purpose of the R1 resistor is to isolate the programmed chip from rest of target system. Recommended value of resistor R1 is 2k or more. You can also use jumpers instead of the resistors.

ISP characteristics:

1. Programmer's output capability:
 - 1.1 Vcc - 80 mA;
 - 1.2 Vpp - 50 mA;
 - 1.3 logical pins - 5 mA.
2. The cable length should be less then one foot.

Table of connections of the adapter output socket to the device pins:

Adapter Output connector, BH-10	Target Device iButton	Tagret Device OneWire
1		Vcc
3		
5		
7		
9	Gnd	Gnd
10		
8		
6		
4	IO	DQ
2		

AE-ISP-U1 connection for the Dallas/Maxim DS89C420/430/440/450 devices

Click the programmer model below to get an appropriate list of the devices supported by the adapter:

- [ChipProg-40](#)
- [ChipProg-48, ChipProg-G4](#)

Recommended connection:

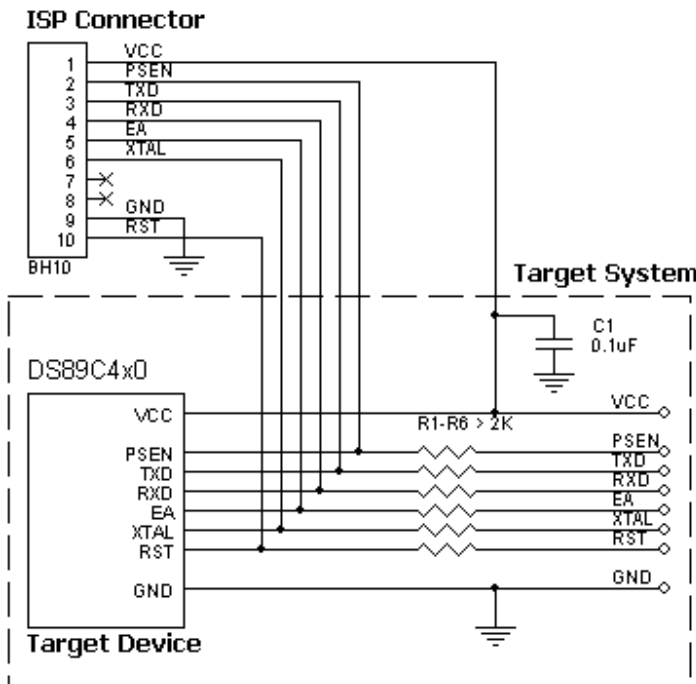

Powering the target device:

There are two alternative options for powering the targets:

1. The target gets power from the programmer (Vdd). This is possible only if the target does not consume too much energy. A capacity of the target power circuitry should not exceed 50 uF.
 2. The target gets power from a built-in or external power supply. In this case the power output from the programmer should not be connected with the target. The target system should be tolerant to applying logical signals with the voltage levels exceeding the voltages on the target.
- NOTE!** It is strictly prohibited to power the target from both the programmer and built-in or external power supply simultaneously.

Isolating resistors:

Purpose of the R1..R6 resistors is to isolate the programmed chip from rest of target system. Recommended value of resistors R1..R6 is 2k or more. You can also use jumpers instead of the resistors.

ISP characteristics:

1. Programmer's output capability:
 - 1.1 Vcc - 80 mA;
 - 1.2 Vpp - 50 mA;
 - 1.3 logical pins - 5 mA.
2. The cable length should be less then one foot.

Table of connections of the adapter output socket to the device pins:

Adapter Output connector, BH-10	Target Device DS89C4x0
1	40
3	11
5	31
7	-
9	20
10	9
8	-
6	19
4	10



AE-ISP-U1 connection for the Freescale HCS08, HCS12 devices

Click the programmer model below to get an appropriate list of the devices supported by the adapter:

- [ChipProg-40](#)
- [ChipProg-48, ChipProg-G4](#)

Recommended connection:

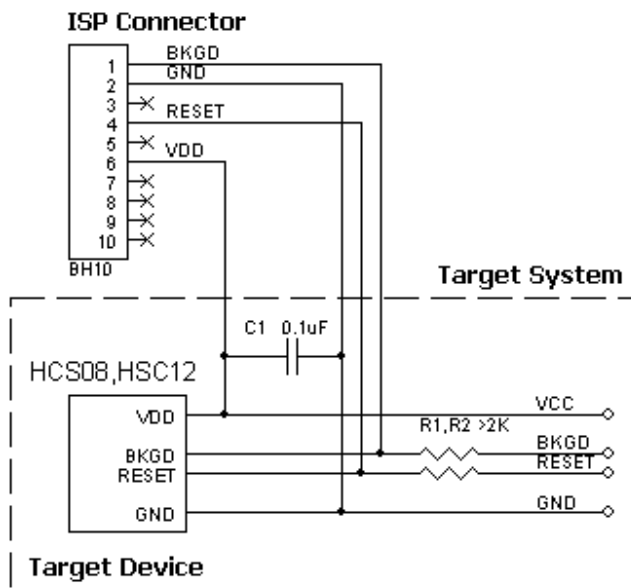

Powering the target device:

There are two alternative options for powering the targets:

1. The target gets power from the programmer (Vdd). This is possible only if the target does not consume too much energy. A capacity of the target power circuitry should not exceed 50 uF.
2. The target gets power from a built-in or external power supply. In this case the power output from the programmer should not be connected with the target. The target system should be tolerant to applying logical signals with the voltage levels exceeding the voltages on the target.

NOTE! It is strictly prohibited to power the target from both the programmer and built-in or external power supply simultaneously.

Isolating resistors:

Purpose of the R1..R2 resistors is to isolate the programmed chip from rest of target system. Recommended value of resistors R1..R2 is 2k or more. You can also use jumpers instead of the resistors.

ISP characteristics:

1. Programmer's output capability:
 - 1.1 Vcc - 80 mA;
 - 1.2 Vpp - 50 mA;
 - 1.3 logical pins - 5 mA.
2. The cable length should be less than one foot.

Table of connections of the adapter output socket to the device pins:

Adapter Output connector, BH-10	Target Device HCS08, HCS12
1	BKGD
2	GND

3	-
4	RESET
5	-
6	VDD
7	-
8	-
9	-
10	

AE-ISP-U1 connection for the Freescale MC68HC908JK1 devices

Click the programmer model below to get an appropriate list of the devices supported by the adapter:

Recommended connection:

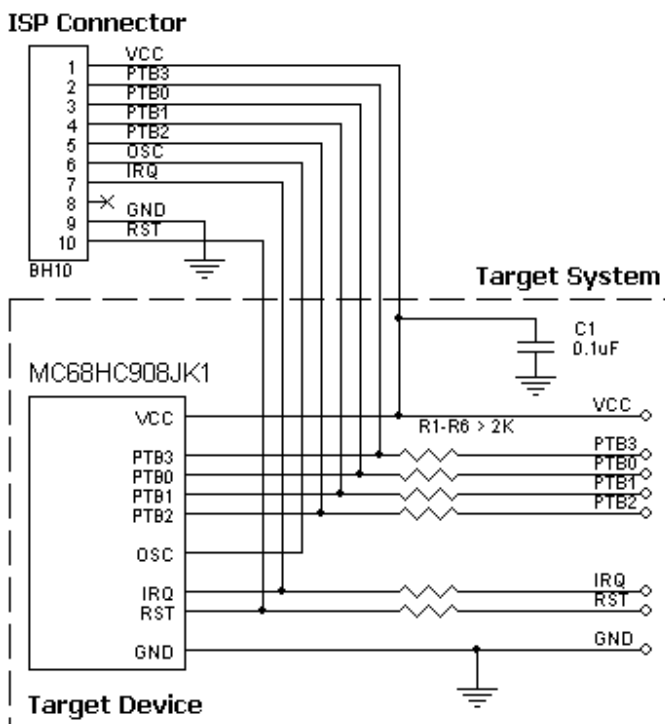

Powering the target device:

There are two alternative options for powering the targets:

1. The target gets power from the programmer (Vdd). This is possible only if the target does not consume too much energy. A capacity of the target power circuitry should not exceed 50 uF.

2. The target gets power from a built-in or external power supply. In this case the power output from the programmer should not be connected with the target. The target system should be tolerant to applying logical signals with the voltage levels exceeding the voltages on the target.

NOTE! It is strictly prohibited to power the target from both the programmer and built-in or external power supply simultaneously.

Isolating resistors:

Purpose of the R1..R6 resistors is to isolate the

programmed chip from rest of target system. Recommended value of resistors R1..R6 is 2k or more. You can also use jumpers instead of the resistors.

ISP characteristics:

1. Programmer's output capability:
 - 1.1 Vcc - 80 mA;
 - 1.2 Vpp - 50 mA;
 - 1.3 logical pins - 5 mA.
2. The cable length should be less then one foot.

Table of connections of the adapter output socket to the device pins:

Adapter Output connector, BH-10	Target Device MC68HC908JK1
1	5
2	12
3	15
4	14
5	13
6	3
7	1
8	-
9	2
10	20

AE-ISP-U1 connection for the Infineon XC886/888CLM, XE164/167 devices

Click the programmer model below to get an appropriate list of the devices supported by the adapter:

- [ChipProg-40](#)
- [ChipProg-48, ChipProg-G4](#)

Recommended connection:

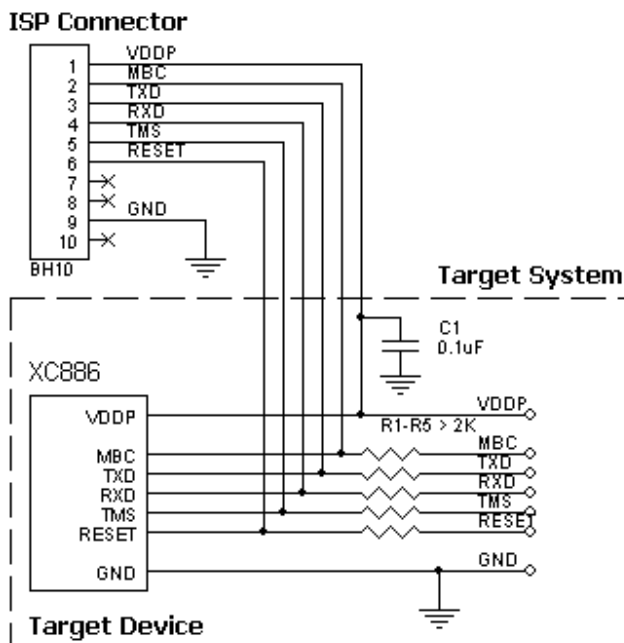

Powering the target device:

There are two alternative options for powering the targets:

1. The target gets power from the programmer (Vdd). This is possible only if the target does not consume too much energy. A capacity of the target power circuitry should not exceed 50 uF.
2. The target gets power from a built-in or external power supply. In this case the power output from the programmer should not be connected with the target. The target system should be tolerant to applying logical signals with the voltage levels exceeding the voltages on the target.

NOTE! It is strictly prohibited to power the target from both the programmer and built-in or external power supply simultaneously.

Isolating resistors:

Purpose of the R1..R5 resistors is to isolate the programmed chip from rest of target system. Recommended value of resistors R1..R5 is 2k or more. You can also use jumpers instead of the resistors.

ISP characteristics:

1. Programmer's output capability:
 - 1.1 Vcc - 80 mA;
 - 1.2 Vpp - 50 mA;
 - 1.3 logical pins - 5 mA.
2. The cable length should be less then one foot.

Table of connections of the adapter output socket to the device pins:

Adapter Output connector, BH-10	Target Device XC886/888CLM	Target Device XE164/167 in 100/144 pins package	Target Device XE164/167 in 64 pins package
1	VDDP	VDDP	VDDP
3	TXD	P7.3 (TxD)	P2.3 (TxD)
5	TMS	P10.1	P10.1
7	-		
9	GND	GND	GND
10	-	P10.2	P10.2
8	-		
6	RESET	PORST	PORST
4	RXD	P7.4 (RxD)	P2.4 (RxD)
2	MBC	P10.0	P10.0

AE-ISP-U1 connection for the Microchip HCS101/HCS201/HCS360/HCS361/HCS362 devices

Click the programmer model below to get an appropriate list of the devices supported by the adapter:

- [ChipProg+](#)
- [ChipProg-40](#)
- [ChipProg-48, ChipProg-G4](#)

Recommended connection:

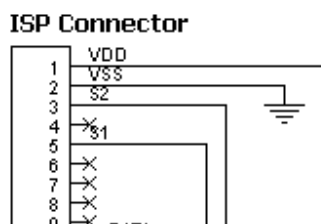

Powering the target device:

There are two alternative options for powering the targets:

1. The target gets power from the programmer (Vdd). This is possible only if the target does not

consume too much energy. A capacity of the target power circuitry should not exceed 50 uF.

2. The target gets power from a built-in or external power supply. In this case the power output from the programmer should not be connected with the target. The target system should be tolerant to applying logical signals with the voltage levels exceeding the voltages on the target.

NOTE! It is strictly prohibited to power the target from both the programmer and built-in or external power supply simultaneously.

Isolating resistors:

Purpose of the R1..R3 resistors is to isolate the programmed chip from rest of target system. Recommended value of resistors R1..R3 is 2k or more. You can also use jumpers instead of the resistors.

ISP characteristics:

1. Programmer's output capability:
 - 1.1 Vcc - 80 mA;
 - 1.2 Vpp - 50 mA;
 - 1.3 logical pins - 5 mA.
2. The cable length should be less than one foot.

Table of connections of the adapter output socket to the device pins:

Adapter Output connector, BH-10	Target Device HCS101	Target Device HCS201	Target Device HCS360	Target Device HCS361	Target Device HCS362
1	Vdd	Vdd	Vdd	Vdd	Vdd
2	Vss	Vss	Vss	Vss	Vss
3	S2	S2	S2	S2	S2
4					
5	S1	S1	S1	S1	S1
6					
7					
8					
9					
10	Data	Data	Data	Data	Data

AE-ISP-U1 connection for the Microchip HCS200/HCS300/HCS301/HCS320 devices

Click the programmer model below to get an appropriate list of the devices supported by the adapter:

- [ChipProg+](#)
- [ChipProg-40](#)
- [ChipProg-48, ChipProg-G4](#)

Recommended connection:

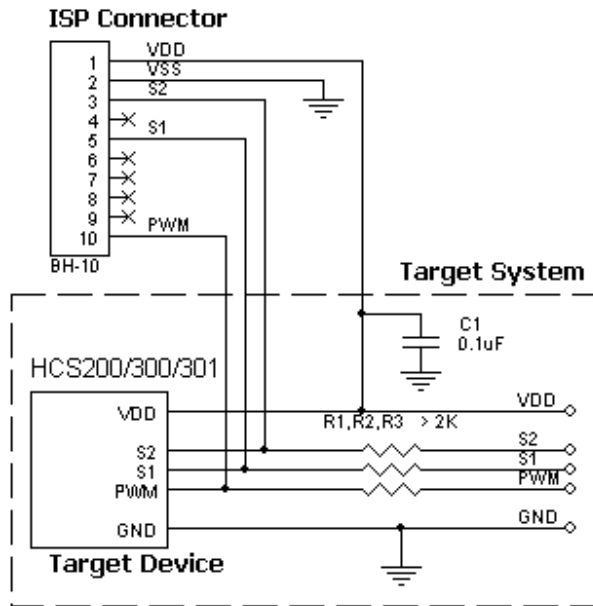

Powering the target device:

There are two alternative options for powering the targets:

1. The target gets power from the programmer (Vdd). This is possible only if the target does not consume too much energy. A capacity of the target power circuitry should not exceed 50 uF.
2. The target gets power from a built-in or external power supply. In this case the power output from the programmer should not be connected with the target. The target system should be tolerant to applying logical signals with the voltage levels exceeding the voltages on the target.

NOTE! It is strictly prohibited to power the target from both the programmer and built-in or external power supply simultaneously.

Isolating resistors:

Purpose of the R1..R3 resistors is to isolate the programmed chip from rest of target system. Recommended value of resistors R1..R3 is 2k or more. You can also use jumpers instead of the resistors.

ISP characteristics:

1. Programmer's output capability:
 - 1.1 Vcc - 80 mA;
 - 1.2 Vpp - 50 mA;
 - 1.3 logical pins - 5 mA.
2. The cable length should be less then one foot.

Table of connections of the adapter output socket to the device pins:

Adapter Output connector, BH-10	Target Device HCS200	Target Device HCS300	Target Device HCS301	Target Device HCS320
1	Vdd	Vdd	Vdd	Vdd
2	Vss	Vss	Vss	Vss
3	S2	S2	S2	S2
4				
5	S1	S1	S1	S1
6				
7				
8				
9				
10	PWM	PWM	PWM	PWM

AE-ISP-U1 connection for the Microchip MC250XX devices

Click the programmer model below to get an appropriate list of the devices supported by the adapter:

- [ChipProg+](#)
- [ChipProg-40](#)
- [ChipProg-48, ChipProg-G4](#)

Recommended connection:

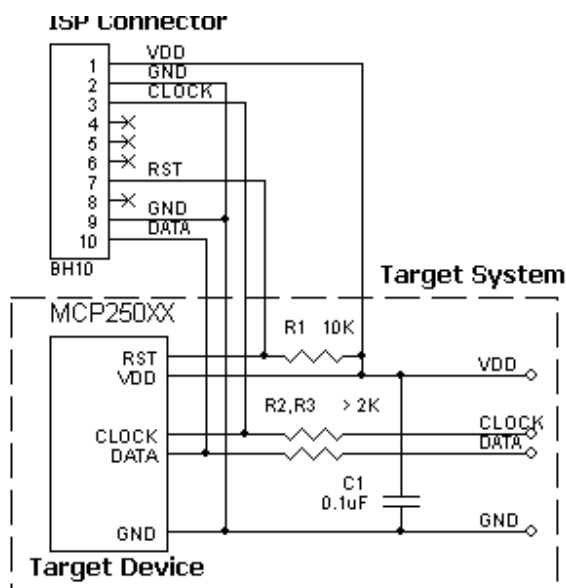

Powering the target device:

There are two alternative options for powering the targets:

1. The target gets power from the programmer (Vdd). This is possible only if the target does not consume too much energy. A capacity of the target power circuitry should not exceed 50 uF.

2. The target gets power from a built-in or external power supply. In this case the power output from the programmer should not be connected with the target. The target system should be tolerant to applying logical signals with the voltage levels exceeding the voltages on the target.

NOTE! It is strictly prohibited to power the target from both the programmer and built-in or external power supply simultaneously.

Isolating resistors:

Purpose of the R2, R3 resistors is to isolate the programmed chip from rest of target system. Recommended value of resistors R2, R3 is 2k or more. You can also use jumpers instead of the resistors.

ISP characteristics:

1. Programmer's output capability:
 - 1.1 Vcc - 80 mA;
 - 1.2 Vpp - 50 mA;
 - 1.3 logical pins - 5 mA.
2. The cable length should be less than one foot.

Table of connections of the adapter output socket to the device pins:

Adapter Output connector, BH-10	Target Device MCP250XX
1	Vdd
3	CLOCK
5	-
7	RST/Vpp

9	GND
10	DATA
8	-
6	-
4	-
2	GND

All power supply pins included AVdd must be powered. All ground pins included AVss must be connected together.

AE-ISP-U1 connection for the Microchip PIC10/PIC12 devices

Click the programmer model below to get an appropriate list of the devices supported by the adapter:

- [ChipProg+](#)
- [ChipProg-40](#)
- [ChipProg-48, ChipProg-G4](#)

Recommended connection:

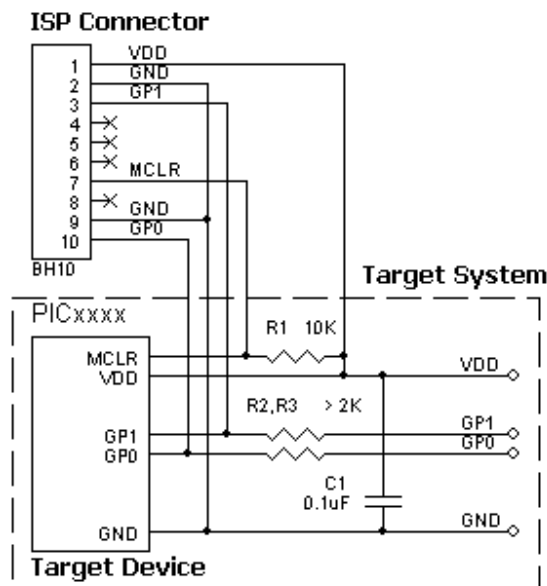

Powering the target device:

There are two alternative options for powering the targets:

1. The target gets power from the programmer (Vdd). This is possible only if the target does not consume too much energy. A capacity of the target power circuitry should not exceed 50 uF.

2. The target gets power from a built-in or external power supply. In this case the power output from the programmer should not be connected with the target. The target system should be tolerant to applying logical signals with the voltage levels exceeding the voltages on the target.

NOTE! It is strictly prohibited to power the target from both the programmer and built-in or external power supply simultaneously.

Isolating resistors:

Purpose of the R2, R3 resistors is to isolate the programmed chip from rest of target system. Recommended value of resistors R2, R3 is 2k or more. You can also use jumpers instead of the resistors.

ISP characteristics:

1. Programmer's output capability:
 - 1.1 Vcc - 80 mA;
 - 1.2 Vpp - 50 mA;

- 1.3 logical pins - 5 mA.
2. The cable length should be less then one foot.

Table of connections of the adapter output socket to the device pins:

Adapter Output connector, BH-10	Target Device PIC10/PIC12
1	Vdd
3	GP1
5	-
7	MCLR/Vpp
9	GND
10	GP0
8	-
6	-
4	-
2	GND

All power supply pins included AVdd must be powered. All ground pins included AVss must be connected together.

AE-ISP-U1 connection for the Microchip PIC16/PIC18 devices

Click the programmer model below to get an appropriate list of the devices supported by the adapter:

- [ChipProg+](#)
- [ChipProg-40](#)
- [ChipProg-48, ChipProg-G4](#)

Recommended connection:

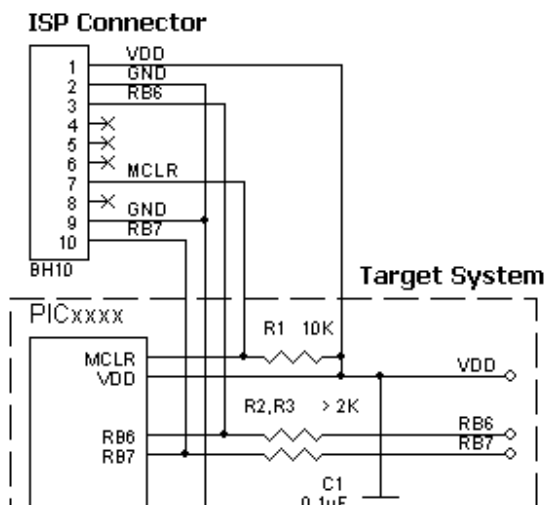

Powering the target device:

There are two alternative options for powering the targets:

1. The target gets power from the programmer (Vdd). This is possible only if the target does not consume too much energy. A capacity of the target power circuitry should not exceed 50 uF.
2. The target gets power from a built-in or external power supply. In this case the power output from the programmer should not be connected with the target. The target system should be tolerant to applying logical signals with the voltage levels exceeding the voltages on the target.

NOTE! It is strictly prohibited to power the target from both the programmer and built-in or external power supply simultaneously.

Isolating resistors:

Purpose of the R2, R3 resistors is to isolate the programmed chip from rest of target system. Recommended value of resistors R2, R3 is 2k or more. You can also use jumpers instead of the resistors.

ISP characteristics:

1. Programmer's output capability:
 - 1.1 Vcc - 80 mA;
 - 1.2 Vpp - 50 mA;
 - 1.3 logical pins - 5 mA.
2. The cable length should be less than one foot.

Table of connections of the adapter output socket to the device pins:

Adapter Output connector, BH-10	Target Device PIC16/PIC18
1	Vdd
3	RB6
5	-
7	MCLR/Vpp
9	GND
10	RB7
8	-
6	-
4	-
2	GND

All power supply pins included AVdd must be powered. All ground pins included AVss must be connected together.

AE-ISP-U1 connection for the Microchip PIC16C505 devices

Click the programmer model below to get an appropriate list of the devices supported by the adapter:

- [ChipProg+](#)
- [ChipProg-40](#)
- [ChipProg-48, ChipProg-G4](#)

Recommended connection:

ISP Connector

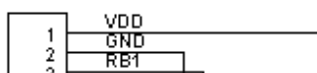

Powering the target device:

There are two alternative options for powering the targets:

1. The target gets power from the programmer (Vdd). This is possible only if the target does not consume too much energy. A capacity of the target power circuitry should not exceed 50 uF.
2. The target gets power from a built-in or external power supply. In this case the power output from the programmer should not be connected with the target. The target system should be tolerant to applying logical signals with the voltage levels exceeding the voltages on the target.

NOTE! It is strictly prohibited to power the target from both the programmer and built-in or external power supply simultaneously.

Isolating resistors:

Purpose of the R2, R3 resistors is to isolate the programmed chip from rest of target system. Recommended value of resistors R2, R3 is 2k or more. You can also use jumpers instead of the resistors.

ISP characteristics:

1. Programmer's output capability:
 - 1.1 Vcc - 80 mA;
 - 1.2 Vpp - 50 mA;
 - 1.3 logical pins - 5 mA.
2. The cable length should be less then one foot.

Table of connections of the adapter output socket to the device pins:

Adapter Output connector, BH-10	Target Device PIC16C505
1	Vdd
3	RB1
5	-
7	MCLR/Vpp
9	GND
10	RB0
8	-
6	-
4	-
2	GND

All power supply pins included AVdd must be powered. All ground pins included AVss must be connected together.

AE-ISP-U1 connection for the Microchip PIC16Fxxx 14..20 pins devices

Click the programmer model below to get an appropriate list of the devices supported by the adapter:

- [ChipProg+](#)
- [ChipProg-40](#)
- [ChipProg-48, ChipProg-G4](#)

Recommended connection:

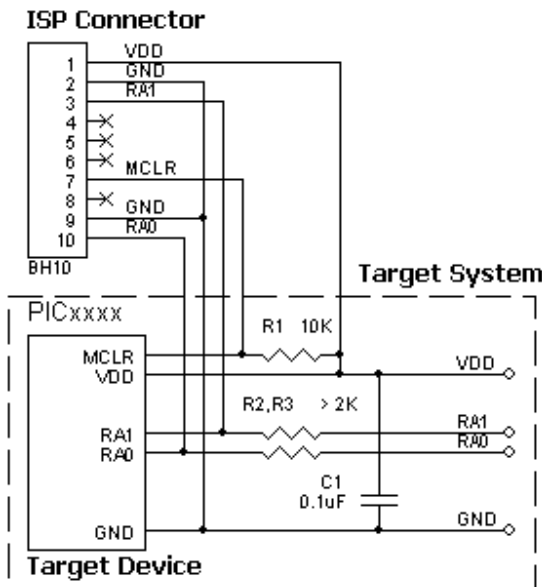

Powering the target device:

There are two alternative options for powering the targets:

1. The target gets power from the programmer (Vdd). This is possible only if the target does not consume too much energy. A capacity of the target power circuitry should not exceed 50 uF.
2. The target gets power from a built-in or external power supply. In this case the power output from the programmer should not be connected with the target. The target system should be tolerant to applying logical signals with the voltage levels exceeding the voltages on the target.

NOTE! It is strictly prohibited to power the target from both the programmer and built-in or external power supply simultaneously.

Isolating resistors:

Purpose of the R2, R3 resistors is to isolate the programmed chip from rest of target system. Recommended value of resistors R2, R3 is 2k or more. You can also use jumpers instead of the resistors.

ISP characteristics:

1. Programmer's output capability:
 - 1.1 Vcc - 80 mA;
 - 1.2 Vpp - 50 mA;
 - 1.3 logical pins - 5 mA.
2. The cable length should be less then one foot.

Table of connections of the adapter output socket to the device pins:

Adapter Output connector, BH-10	Target Device PIC16Fxxx, 14..20 pins package
1	Vdd
3	RA1
5	-
7	MCLR/Vpp
9	GND
10	RA0
8	-
6	-

4	-
2	GND

All power supply pins included AVdd must be powered. All ground pins included AVss must be connected together.

AE-ISP-U1 connection for the Microchip PIC17xxx devices

Click the programmer model below to get an appropriate list of the devices supported by the adapter:

- [ChipProg+](#)
- [ChipProg-40](#)
- [ChipProg-48, ChipProg-G4](#)

Recommended connection:

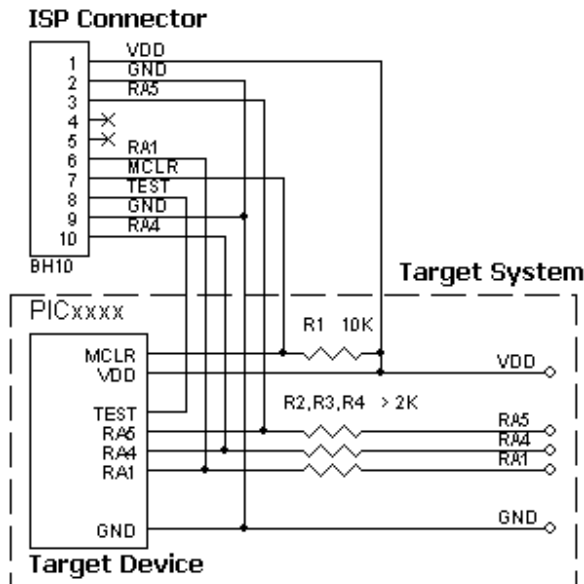

Powering the target device:

There are two alternative options for powering the targets:

1. The target gets power from the programmer (Vdd). This is possible only if the target does not consume too much energy. A capacity of the target power circuitry should not exceed 50 uF.

2. The target gets power from a built-in or external power supply. In this case the power output from the programmer should not be connected with the target. The target system should be tolerant to applying logical signals with the voltage levels exceeding the voltages on the target.

NOTE! It is strictly prohibited to power the target from both the programmer and built-in or external power supply simultaneously.

Isolating resistors:

Purpose of the R2..R4 resistors is to isolate the programmed chip from rest of target system. Recommended value of resistors R2..R4 is 2k or more. You can also use jumpers instead of the resistors.

ISP characteristics:

1. Programmer's output capability:
 - 1.1 Vcc - 80 mA;
 - 1.2 Vpp - 50 mA;
 - 1.3 logical pins - 5 mA.
2. The cable length should be less than one foot.

Table of connections of the adapter output socket to the device pins:

Adapter Output connector, BH-10	Target Device PIC17xxx
1	Vdd
3	RA5
5	-
7	MCLR/V _{pp}
9	GND
10	RA4
8	TEST
6	RA1
4	-
2	GND

All power supply pins included AVdd must be powered. All ground pins included AVss must be connected together.

AE-ISP-U1 connection for the Microchip PIC18FxxJ devices

Click the programmer model below to get an appropriate list of the devices supported by the adapter:

- [ChipProg+](#)
- [ChipProg-40](#)
- [ChipProg-48, ChipProg-G4](#)

Recommended connection:

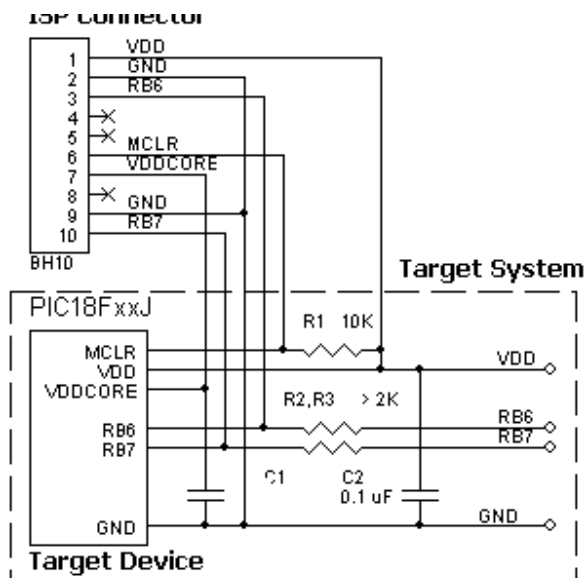

Powering the target device:

There are two alternative options for powering the targets:

1. The target gets power from the programmer (Vdd). This is possible only if the target does not consume too much energy. A capacity of the target power circuitry should not exceed 50 uF.

2. The target gets power from a built-in or external power supply. In this case the power output from the programmer should not be connected with the target. The target system should be tolerant to applying logical signals with the voltage levels exceeding the voltages on the target.

NOTE! It is strictly prohibited to power the target from both the programmer and built-in or external power supply simultaneously.

Isolating resistors:

Purpose of the R2, R3 resistors is to isolate the programmed chip from rest of target system. Recommended value of resistors R2, R3 is 2k or more. You can also use jumpers instead of the

resistors.

ISP characteristics:

1. Programmer's output capability:
 - 1.1 Vcc - 80 mA;
 - 1.2 Vpp - 50 mA;
 - 1.3 logical pins - 5 mA.
2. The cable length should be less than one foot.

Table of connections of the adapter output socket to the device pins:

Adapter Output connector, BH-10	Target Device PIC18FxxJ
1	Vdd
3	RB6
5	-
7	Vddcore*
9	GND
10	RB7
8	-
6	MCLR
4	-
2	GND

All power supply pins included AVdd must be powered. All ground pins included AVss must be connected together.

* -The signal needs to be connected, if it is required.

AE-ISP-U1 connection for the Microchip PIC24 devices

Click the programmer model below to get an appropriate list of the devices supported by the adapter:

- [ChipProg+](#)
- [ChipProg-40](#)
- [ChipProg-48, ChipProg-G4](#)

Recommended connection:

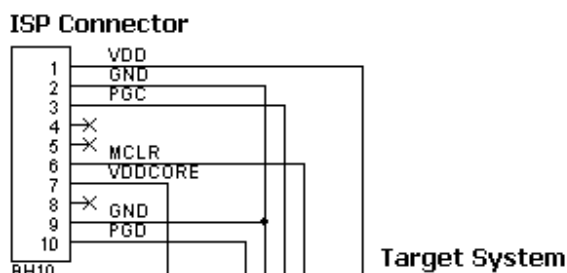

Powering the target device:

There are two alternative options for powering the targets:

1. The target gets power from the programmer (Vdd). This is possible only if the target does not consume too much energy. A capacity of

the target power circuitry should not exceed 50 uF.

2. The target gets power from a built-in or external power supply. In this case the power output from the programmer should not be connected with the target. The target system should be tolerant to applying logical signals with the voltage levels exceeding the voltages on the target.

NOTE! It is strictly prohibited to power the target from both the programmer and built-in or external power supply simultaneously.

Isolating resistors:

Purpose of the R2, R3 resistors is to isolate the programmed chip from rest of target system. Recommended value of resistors R2, R3 is 2k or more. You can also use jumpers instead of the resistors.

ISP characteristics:

1. Programmer's output capability:
 - 1.1 Vcc - 80 mA;
 - 1.2 Vpp - 50 mA;
 - 1.3 logical pins - 5 mA.
2. The cable length should be less then one foot.

Table of connections of the adapter output socket to the device pins:

Adapter Output connector, BH-10	Target Device PIC24
1	Vdd
3	PGC
5	
7	Vddcore*
9	GND
10	PGD
8	
6	MCLR
4	
2	GND

All power supply pins included AVdd must be powered. All ground pins included AVss must be connected together.

* -The signal needs to be connected, if it is required.

AE-ISP-U1 connection for the Microchip dsPIC30F devices

Click the programmer model below to get an appropriate list of the devices supported by the adapter:

- [ChipProg+](#)
- [ChipProg-40](#)
- [ChipProg-48, ChipProg-G4](#)

Recommended connection:

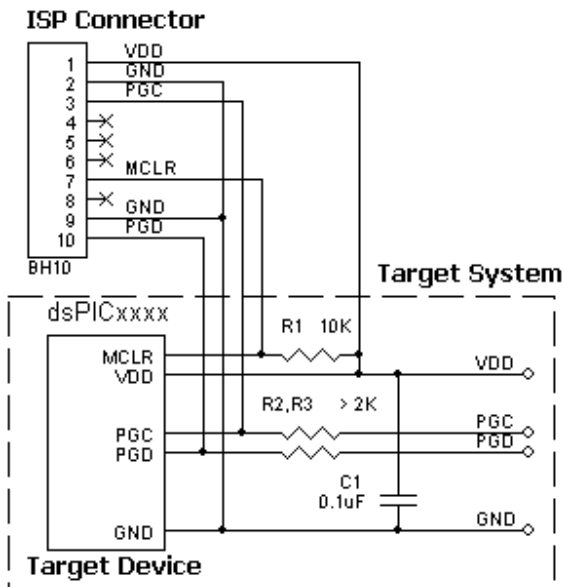

Powering the target device:

There are two alternative options for powering the targets:

1. The target gets power from the programmer (Vdd). This is possible only if the target does not consume too much energy. A capacity of the target power circuitry should not exceed 50 uF.

2. The target gets power from a built-in or external power supply. In this case the power output from the programmer should not be connected with the target. The target system should be tolerant to applying logical signals with the voltage levels exceeding the voltages on the target.

NOTE! It is strictly prohibited to power the target from both the programmer and built-in or external power supply simultaneously.

Isolating resistors:

Purpose of the R2, R3 resistors is to isolate the programmed chip from rest of target system. Recommended value of resistors R2, R3 is 2k or more. You can also use jumpers instead of the resistors.

ISP characteristics:

1. Programmer's output capability:
 - 1.1 Vcc - 80 mA;
 - 1.2 Vpp - 50 mA;
 - 1.3 logical pins - 5 mA.
2. The cable length should be less then one foot.

Table of connections of the adapter output socket to the device pins:

Adapter Output connector, BH-10	Target Device dsPIC30F
1	Vdd
3	PGC
5	
7	MCLR/Vpp
9	GND
10	PGD
8	
6	

4	
2	GND

All power supply pins included AVdd must be powered. All ground pins included AVss must be connected together.

AE-ISP-U1 connection for the Microchip dsPIC33FJ devices

Click the programmer model below to get an appropriate list of the devices supported by the adapter:

- [ChipProg+](#)
- [ChipProg-40](#)
- [ChipProg-48, ChipProg-G4](#)

Recommended connection:

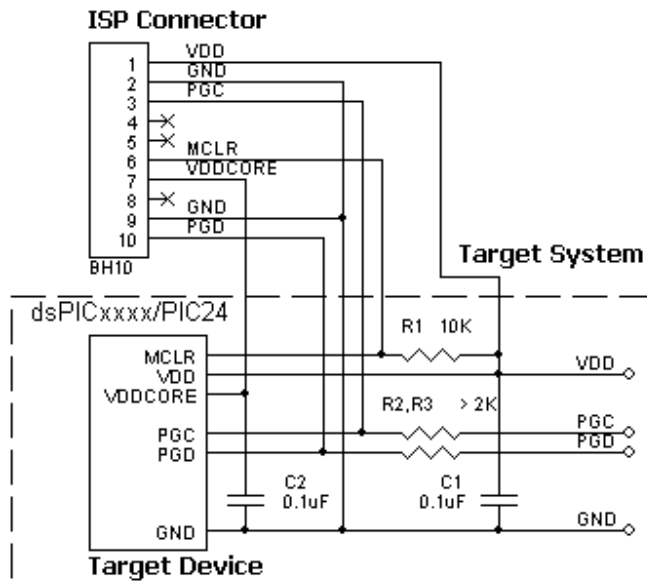

Powering the target device:

There are two alternative options for powering the targets:

1. The target gets power from the programmer (Vdd). This is possible only if the target does not consume too much energy. A capacity of the target power circuitry should not exceed 50 uF.
2. The target gets power from a built-in or external power supply. In this case the power output from the programmer should not be connected with the target. The target system should be tolerant to applying logical signals with the voltage levels exceeding the voltages on the target.

NOTE! It is strictly prohibited to power the target from both the programmer and built-in or

external power supply simultaneously.

Isolating resistors:

Purpose of the R2, R3 resistors is to isolate the programmed chip from rest of target system. Recommended value of resistors R2, R3 is 2k or more. You can also use jumpers instead of the resistors.

ISP characteristics:

1. Programmer's output capability:
 - 1.1 Vcc - 80 mA;
 - 1.2 Vpp - 50 mA;
 - 1.3 logical pins - 5 mA.
2. The cable length should be less then one foot.

Table of connections of the adapter output socket to the device pins:

Adapter Output connector, BH-10	Target Device dsPIC33FJ
1	Vdd
3	PGC
5	
7	Vddcore*
9	GND
10	PGD
8	
6	MCLR
4	
2	GND

All power supply pins included AVdd must be powered. All ground pins included AVss must be connected together.

* -The signal needs to be connected, if it is required.

AE-ISP-U1 connection for the NEC UPD78F9210, UPD78F9211 devices

Click the programmer model below to get an appropriate list of the devices supported by the adapter:

- [ChipProg+](#)
- [ChipProg-40](#)
- [ChipProg-48, ChipProg-G4](#)

Recommended connection:

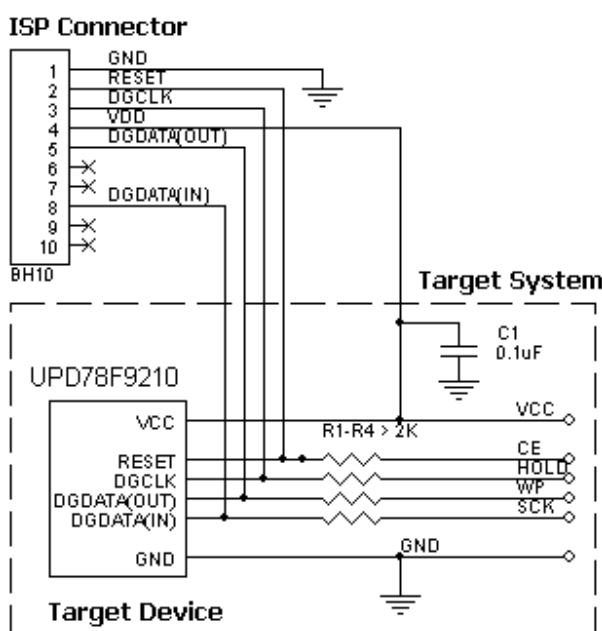

Powering the target device:

There are two alternative options for powering the targets:

1. The target gets power from the programmer (Vdd). This is possible only if the target does not consume too much energy. A capacity of the target power circuitry should not exceed 50 uF.
2. The target gets power from a built-in or external power supply. In this case the power output from the programmer should not be connected with the target. The target system should be tolerant to applying logical signals with the voltage levels exceeding the voltages on the target.

NOTE! It is strictly prohibited to power the target from both the programmer and built-in or external power supply simultaneously.

Isolating resistors:

Purpose of the R1..R4 resistors is to isolate the programmed chip from rest of target system. Recommended value of resistors R1.. R4 is 2k or more. You can also use jumpers instead of the resistors.

ISP characteristics:

1. Programmer's output capability:
 - 1.1 Vcc - 80 mA;
 - 1.2 Vpp - 50 mA;
 - 1.3 logical pins - 5 mA.
2. The cable length should be less then one foot.

Table of connections of the adapter output socket to the device pins:

Adapter Output connector, BH-10	Target Device UPD78F9210	Target Device UPD78F9211
1	4	4
2	12	12
3	8	8
4	5	5
5	9	9
6	--	--
7		
8	9	9
9		
10	-	-

AE-ISP-U1 connection for the NVM3060 device

Click the programmer model below to get an appropriate list of the devices supported by the adapter:

- [ChipProg+](#)
- [ChipProg-48, ChipProg-G4](#)

Recommended connection:

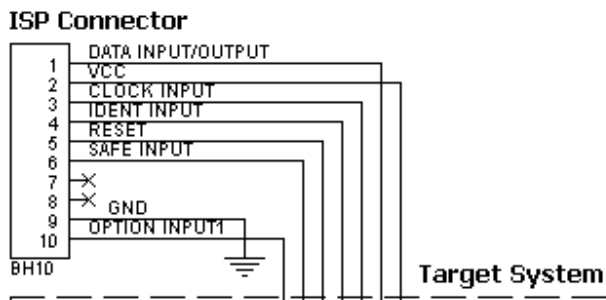

Powering the target device:

There are two alternative options for powering the targets:

1. The target gets power from the programmer (Vdd). This is possible only if the target does not consume too much energy. A capacity of the target power circuitry should not exceed 50 uF.

2. The target gets power from a built-in or external power supply. In this case the power output from the programmer should not be connected with the target. The target system should be tolerant to applying logical signals with the voltage levels exceeding the voltages on the target.

NOTE! It is strictly prohibited to power the target from both the programmer and built-in or external power supply simultaneously.

Isolating resistors:

Purpose of the R1..R6 resistors is to isolate the programmed chip from rest of target system. Recommended value of resistors R1.. R6 is 2k or more. You can also use jumpers instead of the resistors.

ISP characteristics:

1. Programmer's output capability:
 - 1.1 Vcc - 80 mA;
 - 1.2 Vpp - 50 mA;
 - 1.3 logical pins - 5 mA.
2. The cable length should be less than one foot.

Table of connections of the adapter output socket to the device pins:

Adapter Output connector, BH-10	Target Device NVM3060
1	IM Bus Data Input/Output
3	IM Bus Clock Input
5	RESET
7	-
9	GND
10	Option Input
8	-
6	Safe Input S
4	IM Bus Ident Input
2	Vcc

AE-ISP-U1 connection for the NXP/Philips LPC2100/LPC2200 devices in the ISP Mode

Click the programmer model below to get an appropriate list of the devices supported by the adapter:

- [ChipProg-40](#)
- [ChipProg-48, ChipProg-G4](#)

Recommended connection:

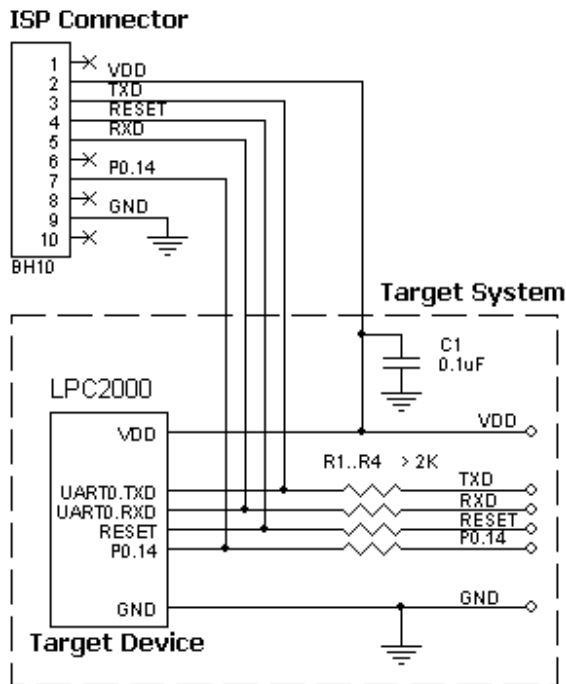

Powering the target device:

There are two alternative options for powering the targets:

1. The target gets power from the programmer (Vdd). This is possible only if the target does not consume too much energy. A capacity of the target power circuitry should not exceed 50 uF.
2. The target gets power from a built-in or external power supply. In this case the power output from the programmer should not be connected with the target. The target system should be tolerant to applying logical signals with the voltage levels exceeding the voltages on the target.

NOTE! It is strictly prohibited to power the target from both the programmer and built-in or external power supply simultaneously.

Isolating resistors:

Purpose of the R1..R4 resistors is to isolate the programmed chip from rest of target system. Recommended value of resistors R1.. R4 is 2k or

more. You can also use jumpers instead of the resistors.

ISP characteristics:

1. Programmer's output capability:
 - 1.1 Vcc - 80 mA;
 - 1.2 Vpp - 50 mA;
 - 1.3 logical pins - 5 mA.
2. The cable length should be less then one foot.

Table of connections of the adapter output socket to the device pins:

Adapter Output connector, BH-10	Target Device LPC21xx/LPC22xx
1	-
3	UART0.TXD
5	UART0.RXD
7	PO.14
9	Vss
10	-
8	-
6	-
4	RESET
2	Vdd

AE-ISP-U1 connection for the NXP/Philips LPC2300/LPC2400 devices in the ISP Mode

Click the programmer model below to get an appropriate list of the devices supported by the adapter:

- [ChipProg-40](#)
- [ChipProg-48, ChipProg-G4](#)

Recommended connection:

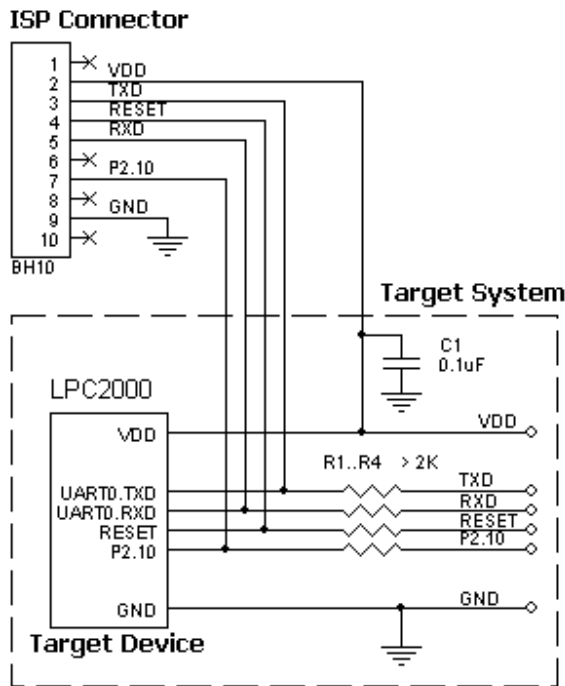

Powering the target device:

There are two alternative options for powering the targets:

1. The target gets power from the programmer (Vdd). This is possible only if the target does not consume too much energy. A capacity of the target power circuitry should not exceed 50 uF.

2. The target gets power from a built-in or external power supply. In this case the power output from the programmer should not be connected with the target. The target system should be tolerant to applying logical signals with the voltage levels exceeding the voltages on the target.

NOTE! It is strictly prohibited to power the target from both the programmer and built-in or external power supply simultaneously.

Isolating resistors:

Purpose of the R1..R4 resistors is to isolate the programmed chip from rest of target system.

Recommended value of resistors R1.. R4 is 2k or more. You can also use jumpers instead of the resistors.

ISP characteristics:

1. Programmer's output capability:
 - 1.1 Vcc - 80 mA;
 - 1.2 Vpp - 50 mA;
 - 1.3 logical pins - 5 mA.
2. The cable length should be less then one foot.

Table of connections of the adapter output socket to the device pins:

Adapter Output connector, BH-10	Target Device LPC23xx/LPC24xx
1	-
3	UART0.TXD
5	UART0.RXD
7	P2.10
9	Vss
10	-

8	-
6	-
4	RESET
2	Vdd

AE-ISP-U1 connection for the NXP/Philips P89LPC9xx devices in the ISP Mode

Click the programmer model below to get an appropriate list of the devices supported by the adapter:

- [ChipProg-40](#)
- [ChipProg-48, ChipProg-G4](#)

Recommended connection:

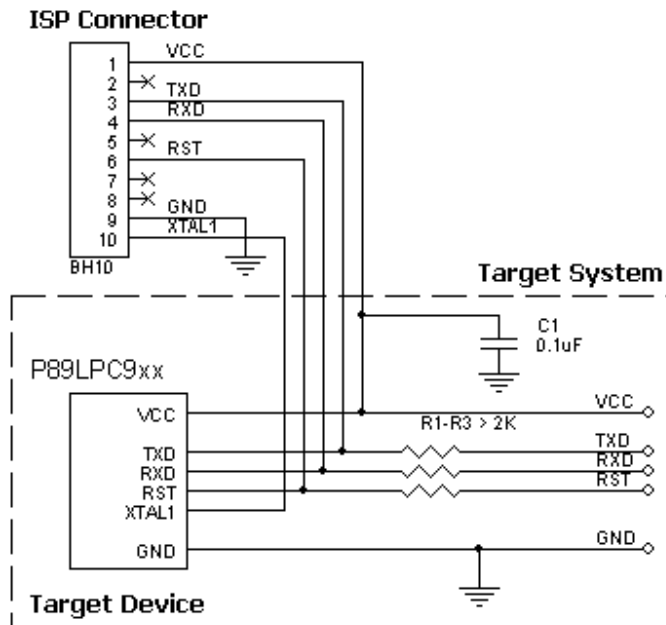

Powering the target device:

There are two alternative options for powering the targets:

1. The target gets power from the programmer (Vdd). This is possible only if the target does not consume too much energy. A capacity of the target power circuitry should not exceed 50 uF.
2. The target gets power from a built-in or external power supply. In this case the power output from the programmer should not be connected with the target. The target system should be tolerant to applying logical signals with the voltage levels exceeding the voltages on the target.

NOTE! It is strictly prohibited to power the target from both the programmer and built-in or external power supply simultaneously.

Isolating resistors:

Purpose of the R1..R3 resistors is to isolate the programmed chip from rest of target system. Recommended value of resistors R1.. R3 is 2k or more. You can also use jumpers instead of the resistors.

ISP characteristics:

1. Programmer's output capability:
 - 1.1 Vcc - 80 mA;
 - 1.2 Vpp - 50 mA;
 - 1.3 logical pins - 5 mA.
2. The cable length should be less then one foot.

Table of connections of the adapter output socket to the device pins:

Adapter Output connector, BH-10	Target Device P89LPC9xx
1	VCC
3	TXD
5	
7	
9	GND
10	XTAL1*
8	
6	RST
4	RXD
2	

* Must be connected if there is no external oscillator in system.

AE-ISP-U1 connection for the NXP/Philips P89xxx devices in the ICP Mode

Click the programmer model below to get an appropriate list of the devices supported by the adapter:

- [ChipProg+](#)
- [ChipProg-40](#)
- [ChipProg-48, ChipProg-G4](#)

Recommended connection:

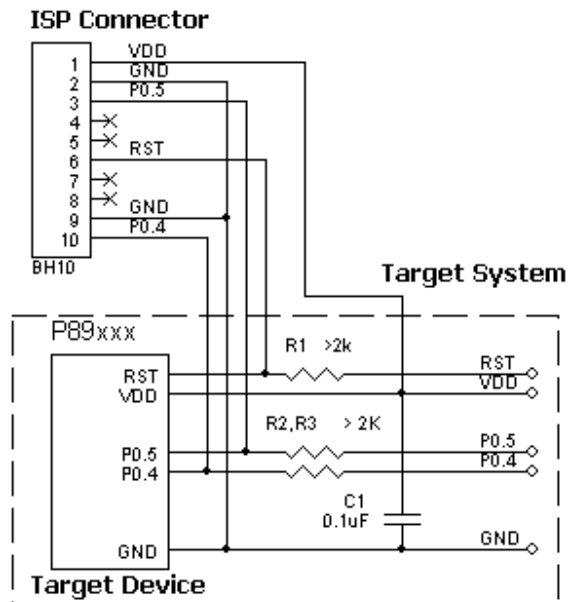

Powering the target device:

There are two alternative options for powering the targets:

1. The target gets power from the programmer (Vdd). This is possible only if the target does not consume too much energy. A capacity of the target power circuitry should not exceed 50 uF.
2. The target gets power from a built-in or external power supply. In this case the power output from the programmer should not be connected with the target. The target system should be tolerant to applying logical signals with the voltage levels exceeding the voltages on the target.

NOTE! It is strictly prohibited to power the target from both the programmer and built-in or external power supply simultaneously.

Isolating resistors:

Purpose of the R1..R3 resistors is to isolate the programmed chip from rest of target system. Recommended value of resistors R1.. R3 is 2k or more. You can also use jumpers instead of the resistors.

ISP characteristics:

1. Programmer's output capability:
 - 1.1 Vcc - 80 mA;
 - 1.2 Vpp - 50 mA;
 - 1.3 logical pins - 5 mA.
2. The cable length should be less then one foot.

Table of connections of the adapter output socket to the device pins:

Adapter Output connector, BH-10	Target Device P89LPC9xx	Target Device P89V52X2
1	Vdd	Vdd
3	P0.5	P0.5
5	-	-
7	-	-
9	Vss	Vss
10	P0.4	P0.4
8	-	-
6	RST	RST
4	-	-
2	Vss	Vss

AE-ISP-U1 connection for the Nordic microcontrollers

Click the programmer model below to get an appropriate list of the devices supported by the adapter:

- [ChipProg-48, ChipProg-G4](#)

Recommended connection:

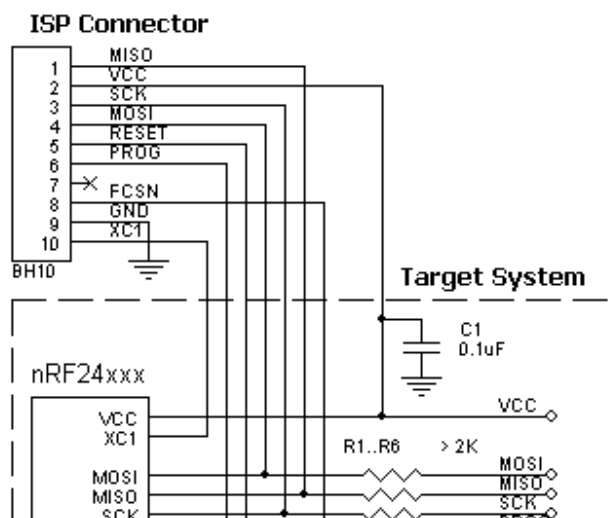

Powering the target device:

There are two alternative options for powering the targets:

1. The target gets power from the programmer (Vdd). This is possible only if the target does not consume too much energy. A capacity of the target power circuitry should not exceed 50 uF.
2. The target gets power from a built-in or external power supply. In this case the power output from the programmer should not be connected with the target. The target system should be tolerant to applying logical signals with the voltage levels exceeding the voltages

on the target.

NOTE! It is strictly prohibited to power the target from both the programmer and built-in or external power supply simultaneously.

Isolating resistors:

Purpose of the R1..R6 resistors is to isolate the programmed chip from rest of target system. Recommended value of resistors R1..R6 is 2k or more. You can also use jumpers instead of the resistors.

ISP characteristics:

1. Programmer's output capability:
 - 1.1 Vcc - 80 mA;
 - 1.2 Vpp - 50 mA;
 - 1.3 logical pins - 5 mA.
2. The cable length should be less then one foot.

Table of connections of the adapter output socket to the device pins:

Adapter Output connector, BH-10	Nordic nRF24xxx
1	MISO
3	SCK
5	RESET
7	-
9	GND
10	XC1*
8	FCSN
6	PROG
4	MOSI
2	Vcc

* Must be connected if there is no external oscillator in system.

AE-ISP-U1 connection for the SST SST26xx

Click the programmer model below to get an appropriate list of the devices supported by the adapter:

Recommended connection:

ISP Connector

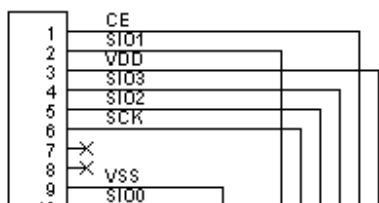

Powering the target device:

There are two alternative options for powering the targets:

1. The target gets power from the programmer (Vdd). This is possible only if

the target does not consume too much energy. A capacity of the target power circuitry should not exceed 50 uF.

2. The target gets power from a built-in or external power supply. In this case the power output from the programmer should not be connected with the target. The target system should be tolerant to applying logical signals with the voltage levels exceeding the voltages on the target.

NOTE! It is strictly prohibited to power the target from both the programmer and built-in or external power supply simultaneously.

Isolating resistors:

Purpose of the R1..R6 resistors is to isolate the programmed chip from rest of target system. Recommended value of resistors R1.. R6 is 2k or more. You can also use jumpers instead of the resistors.

ISP characteristics:

1. Programmer's output capability:
 - 1.1 Vcc - 80 mA;
 - 1.2 Vpp - 50 mA;
 - 1.3 logical pins - 5 mA.
2. The cable length should be less then one foot.

Table of connections of the adapter output socket to the device pins:

Adapter Output connector, BH-10	Target Device SST26xx
1	1
3	8
5	3
7	-
9	4
10	5
8	
6	6
4	7
2	2

AE-ISP-U1 connection for the STMicroelectronics M35080

Click the programmer model below to get an appropriate list of the devices supported by the adapter:

Recommended connection:

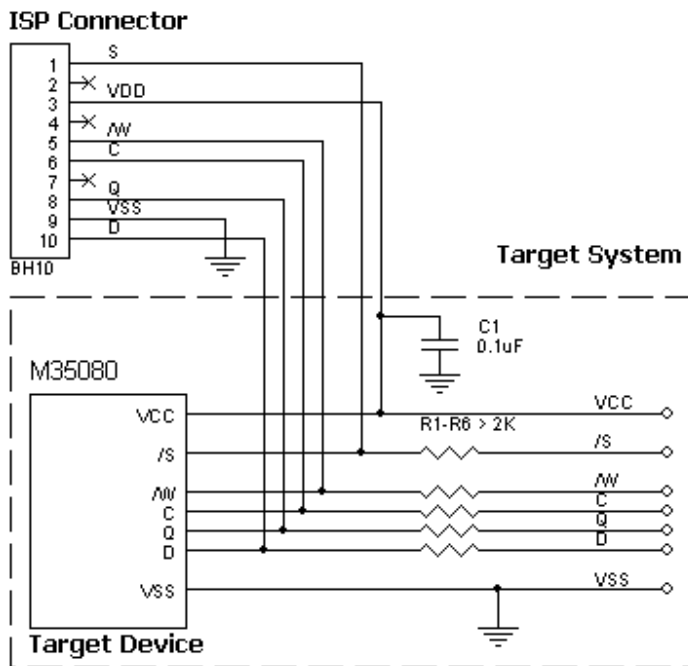

Powering the target device:

There are two alternative options for powering the targets:

1. The target gets power from the programmer (Vdd). This is possible only if the target does not consume too much energy. A capacity of the target power circuitry should not exceed 50 uF.
2. The target gets power from a built-in or external power supply. In this case the power output from the programmer should not be connected with the target. The target system should be tolerant to applying logical signals with the voltage levels exceeding the voltages on the target.

NOTE! It is strictly prohibited to power the target from both the programmer and built-in or external power supply simultaneously.

Isolating resistors:

Purpose of the R1..R6 resistors is to isolate the programmed chip from rest of target system. Recommended value of resistors R1.. R6 is 2k or more. You can also use jumpers instead of the resistors.

ISP characteristics:

1. Programmer's output capability:
 - 1.1 Vcc - 80 mA;
 - 1.2 Vpp - 50 mA;
 - 1.3 logical pins - 5 mA.
2. The cable length should be less then one foot.

Table of connections of the adapter output socket to the device pins:

Adapter Output connector, BH-10	Target Device M35080
1	1
3	8
5	3
7	-
9	4
10	5
8	2
6	6
4	7
2	-

AE-ISP-U1 connection for the STMicroelectronics M45Pxxx devices

Click the programmer model below to get an appropriate list of the devices supported by the adapter:

Recommended connection:

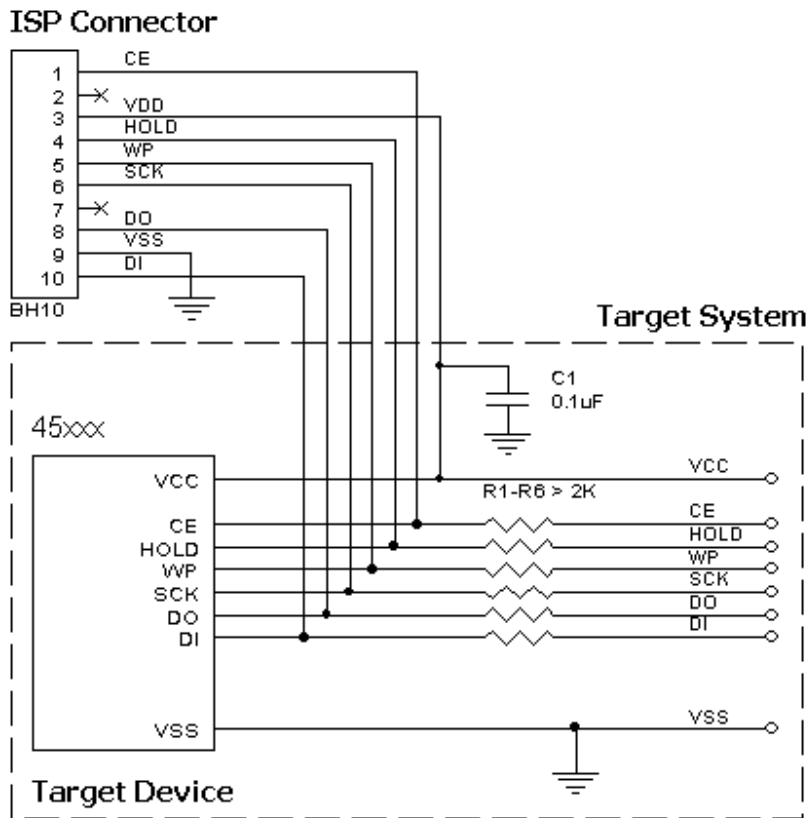

Powering the target device:

There are two alternative options for powering the targets:

1. The target gets power from the programmer (Vdd). This is possible only if the target does not consume too much energy. A capacity of the target power circuitry should not exceed 50 uF.
2. The target gets power from a built-in or external power supply. In this case the power output from the programmer should not be connected with the target. The target system should be tolerant to applying logical signals with the voltage levels exceeding the voltages on the target.

NOTE! It is strictly prohibited to power the target from both the programmer and built-in or external power supply simultaneously.

Isolating resistors:

Purpose of the R1..R6 resistors is to isolate the programmed chip from rest of target system. Recommended value of resistors R1.. R6 is 2k or more. You can also use jumpers instead of the resistors.

ISP characteristics:

1. Programmer's output capability:
 - 1.1 Vcc - 80 mA;
 - 1.2 Vpp - 50 mA;
 - 1.3 logical pins - 5 mA.
2. The cable length should be less then one foot.

Table of connections of the adapter output socket to the device pins:

Adapter Output connector, BH-10	Target Device M45xxx 8 pins package	Target Device M45xxx 16 pins package
1	4	10
3	6	16

5	5	15
7	-	-
9	7	1
10	1	7
8	8	2
6	2	8
4	3	9
2	-	-

AE-ISP-U1 connection for the STMicroelectronics STM32 devices in the BootLoader (BL) Mode

Click the programmer model below to get an appropriate list of the devices supported by the adapter:

- [ChipProg-40](#)
- [ChipProg-48, ChipProg-G4](#)

Recommended connection:

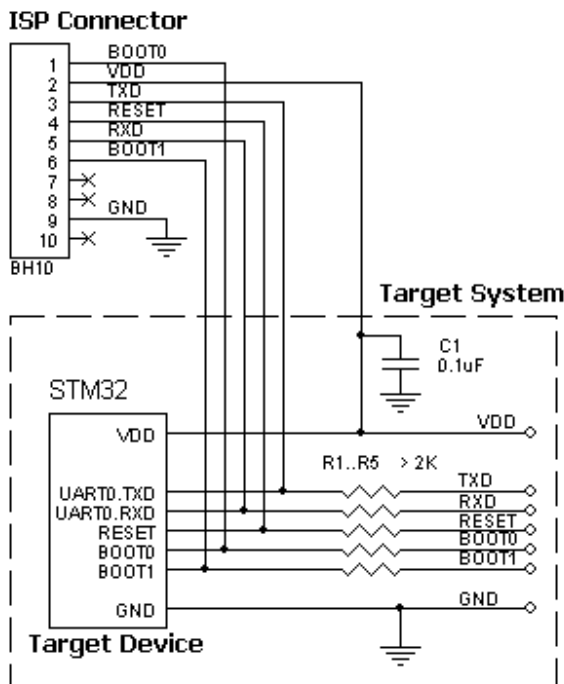

Powering the target device:

There are two alternative options for powering the targets:

1. The target gets power from the programmer (Vdd). This is possible only if the target does not consume too much energy. A capacity of the target power circuitry should not exceed 50 uF.
2. The target gets power from a built-in or external power supply. In this case the power output from the programmer should not be connected with the target. The target system should be tolerant to applying logical signals with the voltage levels exceeding the voltages on the target.

NOTE! It is strictly prohibited to power the target from both the programmer and built-in or external power supply simultaneously.

Isolating resistors:

Purpose of the R1..R5 resistors is to isolate the programmed chip from rest of target system.

Recommended value of resistors R1.. R5 is 2k or more. You can also use jumpers instead of the resistors.

ISP characteristics:

1. Programmer's output capability:
1.1 Vcc - 80 mA;

- 1.2 Vpp - 50 mA;
- 1.3 logical pins - 5 mA.
- 2. The cable length should be less then one foot.

Table of connections of the adapter output socket to the device pins:

Adapter Output connector, BH-10	Target Device STM32Fxxx
1	BOOT0
3	UART0.TXD
5	UART0.RXD
7	-
9	Vss
10	-
8	-
6	BOOT1
4	RESET
2	Vdd

AE-ISP-U1 connection for the TI MSP430 devices in the BSL Mode with the TEST pin

Click the programmer model below to get an appropriate list of the devices supported by the adapter:

- [ChipProg-40](#)
- [ChipProg-48, ChipProg-G4](#)

Recommended connection:

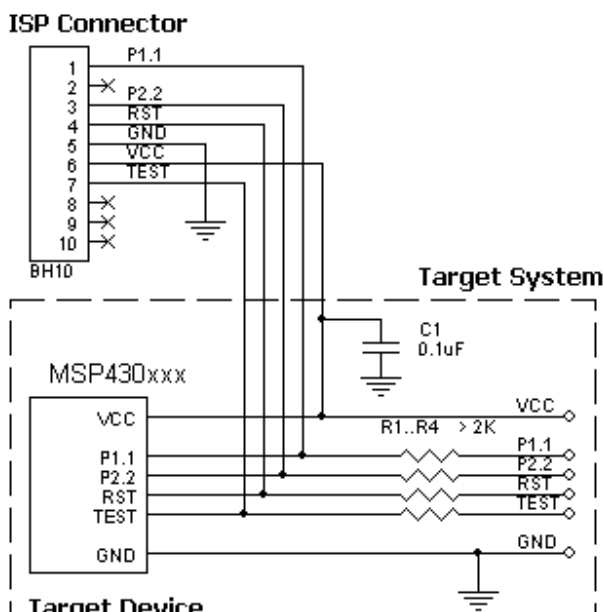

Powering the target device:

There are two alternative options for powering the targets:

1. The target gets power from the programmer (Vdd). This is possible only if the target does not consume too much energy. A capacity of the target power circuitry should not exceed 50 uF.
2. The target gets power from a built-in or external power supply. In this case the power output from the programmer should not be connected with the target. The target system should be tolerant to applying logical signals with the voltage levels exceeding the voltages on the target.

NOTE! It is strictly prohibited to power the target from both the programmer and built-in or external power supply simultaneously.

Isolating resistors:

Purpose of the R1..R4 resistors is to isolate the programmed chip from rest of target system. Recommended value of resistors R1.. R4 is 2k or more. You can also use jumpers instead of the resistors.

ISP characteristics:

1. Programmer's output capability:
 - 1.1 Vcc - 80 mA;
 - 1.2 Vpp - 50 mA;
 - 1.3 logical pins - 5 mA.
2. The cable length should be less then one foot.

Table of connections of the adapter output socket to the device pins:

Adapter Output connector, BH-10	MSP430 with TEST pin
1	P1.1
2	-
3	P2.2
4	RST/NMI
5	GND
6	VCC
7	TEST
8	-
9	-
10	-

AE-ISP-U1 connection for the TI MSP430F13x/14x devices in the BSL Mode

Click the programmer model below to get an appropriate list of the devices supported by the adapter:

- [ChipProg-40](#)
- [ChipProg-48, ChipProg-G4](#)

Recommended connection:

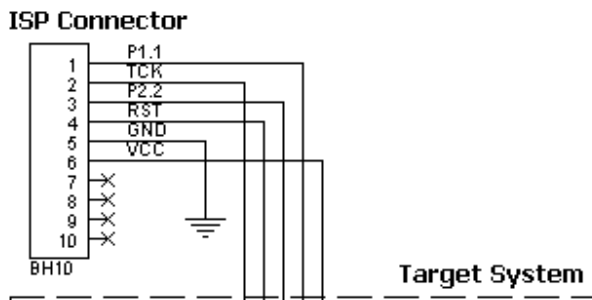

Powering the target device:

There are two alternative options for powering the targets:

1. The target gets power from the programmer (Vdd). This is possible only if the target does not consume too much energy. A capacity of the target power circuitry should not exceed 50 uF.

2. The target gets power from a built-in or external power supply. In this case the power output from the programmer should not be connected with the target. The target system should be tolerant to applying logical signals with the voltage levels exceeding the voltages on the target.

NOTE! It is strictly prohibited to power the target from both the programmer and built-in or external power supply simultaneously.

Isolating resistors:

Purpose of the R1..R4 resistors is to isolate the programmed chip from rest of target system. Recommended value of resistors R1.. R4 is 2k or more. You can also use jumpers instead of the resistors.

ISP characteristics:

1. Programmer's output capability:
 - 1.1 Vcc - 80 mA;
 - 1.2 Vpp - 50 mA;
 - 1.3 logical pins - 5 mA.
2. The cable length should be less then one foot.

Table of connections of the adapter output socket to the device pins:

Adapter Output connector, BH-10	Target Device MSP430F13x, MSP430F14x
1	P1.1
2	TCK
3	P2.2
4	RST/NMI
5	GND
6	VCC
7	-
8	-
9	-
10	-

AE-ISP-U1 connection for the TI MSP430F4xx devices in the BSL Mode

Click the programmer model below to get an appropriate list of the devices supported by the adapter:

- [ChipProg-40](#)
- [ChipProg-48, ChipProg-G4](#)

Recommended connection:



Powering the target device:

There are two alternative options for powering the targets:

1. The target gets power from the programmer (Vdd). This is possible only if the target does not consume too much energy. A capacity of the target power circuitry should not exceed 50 uF.
2. The target gets power from a built-in or external power supply. In this case the power output from the programmer should not be connected with the target. The target system should be tolerant to applying logical signals with the voltage levels exceeding the voltages on the target.

NOTE! It is strictly prohibited to power the target from both the programmer and built-in or external power supply simultaneously.

Isolating resistors:

Purpose of the R1..R4 resistors is to isolate the programmed chip from rest of target system.

Recommended value of resistors R1.. R4 is 2k or more. You can also use jumpers instead of the resistors.

ISP characteristics:

1. Programmer's output capability:
 - 1.1 Vcc - 80 mA;
 - 1.2 Vpp - 50 mA;
 - 1.3 logical pins - 5 mA.
2. The cable length should be less then one foot.

Table of connections of the adapter output socket to the device pins:

Adapter Output connector, BH-10	Target Device MSP430F4xx
1	P1.0
2	TCK
3	P1.1
4	RST/NMI
5	GND
6	VCC
7	-
8	-
9	-
10	-

AE-ISP-U1 connection for the Zilog Z8F devices

Click the programmer model below to get an appropriate list of the devices supported by the adapter:

- [ChipProg+](#)
- [ChipProg-48, ChipProg-G4](#)

Recommended connection:

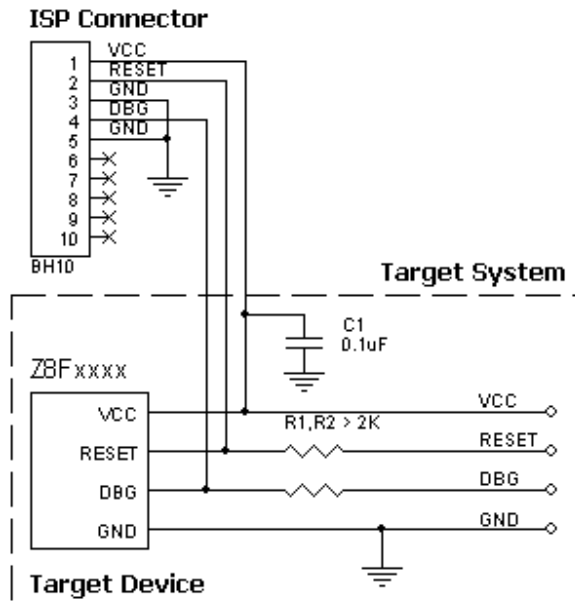

Powering the target device:

There are two alternative options for powering the targets:

1. The target gets power from the programmer (Vdd). This is possible only if the target does not consume too much energy. A capacity of the target power circuitry should not exceed 50 uF.

2. The target gets power from a built-in or external power supply. In this case the power output from the programmer should not be connected with the target. The target system should be tolerant to applying logical signals with the voltage levels exceeding the voltages on the target.

NOTE! It is strictly prohibited to power the target from both the programmer and built-in or external power supply simultaneously.

Isolating resistors:

Purpose of the R1,R2 resistors is to isolate the programmed chip from rest of target system. Recommended value of resistors R1, R2 is 2k or more. You can also use jumpers instead of the resistors.

ISP characteristics:

1. Programmer's output capability:
 - 1.1 Vcc - 80 mA;
 - 1.2 Vpp - 50 mA;
 - 1.3 logical pins - 5 mA.
2. The cable length should be less then one foot.

Table of connections of the adapter output socket to the device pins:

Adapter Output connector, BH-10	Target Device Z8Fxxxx
1	Vcc
2	RESET
3	GND
4	DBG
5	GND
6	
7	
8	
9	

