

Excellent Integrated System Limited

Stocking Distributor

Click to view price, real time Inventory, Delivery & Lifecycle Information:

[Texas Instruments](#)
[REF5025SKGD1](#)

For any questions, you can email us directly:

sales@integrated-circuit.com

LOW NOISE, VERY LOW DRIFT, PRECISION VOLTAGE REFERENCE

Check for Samples: [REF5025-HT](#)

FEATURES

- Low Temperature Drift: 40 ppm/°C
- Low Noise: 3 $\mu\text{V}_{\text{pp}}/\text{V}$
- High Output Current: ± 7 mA

APPLICATIONS

- Down-Hole Drilling
- High Temperature Environments

SUPPORTS EXTREME TEMPERATURE APPLICATIONS

- Controlled Baseline
- One Assembly/Test Site
- One Fabrication Site
- Available in Extreme ($-55^{\circ}\text{C}/210^{\circ}\text{C}$) Temperature Range ⁽¹⁾
- Extended Product Life Cycle
- Extended Product-Change Notification
- Product Traceability
- Texas Instruments high temperature products utilize highly optimized silicon (die) solutions with design and process enhancements to maximize performance over extended temperatures.

(1) Custom temperature ranges available

DESCRIPTION

The REF5025 is a low-noise, low-drift, very high precision voltage reference. This reference is capable of both sinking and sourcing, and is very robust with regard to line and load changes.

Temperature drift (40 ppm/°C) from -55°C to 210°C is achieved using proprietary design techniques. These features combined with very low noise make the REF5025 ideal for use in down-hole drilling applications.

HKJ PACKAGE
(TOP VIEW)

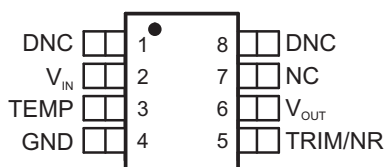

DNC = Do not connect
 NC = No internal connection

HKQ PACKAGE
(TOP VIEW)

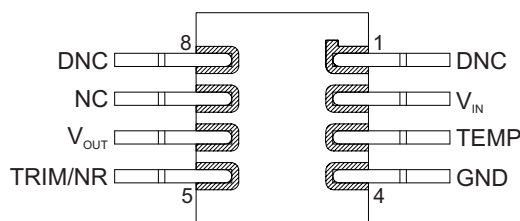

HKQ as formed or HKJ mounted dead bug



Please be aware that an important notice concerning availability, standard warranty, and use in critical applications of Texas Instruments semiconductor products and disclaimers thereto appears at the end of this data sheet.

All trademarks are the property of their respective owners.

SBOS502E –SEPTEMBER 2009–REVISED NOVEMBER 2013

www.ti.com



This integrated circuit can be damaged by ESD. Texas Instruments recommends that all integrated circuits be handled with appropriate precautions. Failure to observe proper handling and installation procedures can cause damage.

ESD damage can range from subtle performance degradation to complete device failure. Precision integrated circuits may be more susceptible to damage because very small parametric changes could cause the device not to meet its published specifications.

BARE DIE INFORMATION

DIE THICKNESS	BACKSIDE FINISH	BACKSIDE POTENTIAL	BOND PAD METALLIZATION COMPOSITION	BOND PAD THICKNESS
15 mils.	Silicon with backgrind	GND	Al-Cu (0.5%)	598 nm

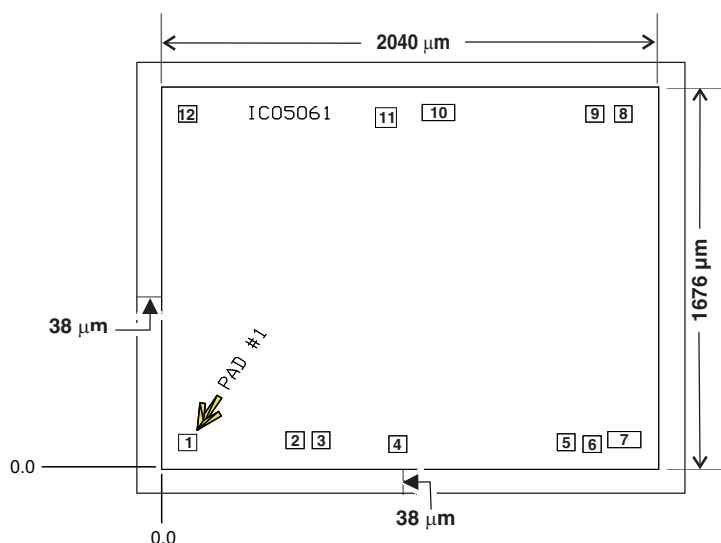

Table 1. Bond Pad Coordinates in Microns

DISCRIPTION	PAD NUMBER	X min	Y min	X max	Y max
NC	1	35.45	46.55	111.45	122.55
NC	2	496.75	56.55	572.75	132.55
VIN	3	607.45	56.55	683.45	132.55
NC	4	937.9	39.4	1013.9	115.4
TEMP	5	1660.1	47.2	1736.1	123.2
GND	6	1770.9	38.85	1847.05	115
GND	7	1877.1	59.6	2016.8	135.6
TRIM/NR	8	1904.65	1553.4	1980.65	1629.4
NC	9	1782.15	1553.4	1858.15	1629.4
VOUT	10	1080.2	1559.85	1219.9	1636
VOUT	11	880.25	1543.55	956.25	1619.55
NC	12	35.45	1553.45	111.45	1629.45

ORDERING INFORMATION⁽¹⁾

T _A	PACKAGE	ORDERABLE PART NUMBER	TOP-SIDE MARKING
-55°C to 210°C	KGD (bare die)	REF5025SKGD1	NA
		REF5025SKGD2	
	HKJ	REF5025SHKJ	REF5025SHKJ
	HKQ	REF5025SHKQ	REF5025SHKQ

(1) For the most current package and ordering information, see the Package Option Addendum at the end of this document, or see the TI web site at www.ti.com.

ABSOLUTE MAXIMUM RATINGS⁽¹⁾

			UNIT
Input Voltage		18	V
Output Short-Circuit		30	mA
Operating Temperature Range		–55 to 210	°C
Storage Temperature Range		–65 to 210	°C
Junction Temperature (T _J max)		210	°C
ESD Rating	Human Body Model (HBM)	3000	V
	Charged Device Model (CDM)	1000	V

(1) Stresses above these ratings may cause permanent damage. Exposure to absolute maximum conditions for extended periods may degrade device reliability. These are stress ratings only, and functional operation of the device at these or any other conditions beyond those specified is not implied.

THERMAL CHARACTERISTICS FOR HKJ OR HKQ PACKAGE

over operating free-air temperature range (unless otherwise noted)

PARAMETER		MIN	TYP	MAX	UNIT	
θ _{JC}	Junction-to-case thermal resistance	to ceramic side of case			5.7	°C/W
		to top of case lid (metal side of case)			13.7	

ELECTRICAL CHARACTERISTICS

 T_A = 25°C, I_{LOAD} = 0, C_L = 1 μF, V_{IN} = 3.25 V to 18 V (unless otherwise noted).

PARAMETER	CONDITIONS	T _A = –55 to 125°C			T _A = 210°C			UNIT
		MIN	TYP	MAX	MIN	TYP	MAX	
OUTPUT VOLTAGE (2.5 V)								
Output voltage V _{OUT}	V _{IN} = 3.25 V		2.5		2.5			V
Initial accuracy ⁽¹⁾		0		0.9	0.14			%
NOISE								
Output voltage noise	f = 0.1 Hz to 10 Hz		7.5					μV _{PP}
OUTPUT VOLTAGE TEMPERATURE DRIFT								
Output voltage temperature drift ⁽²⁾ dV _{OUT} /dT	Calculated from –55°C to 210°C						40	ppm/°C
LINE REGULATION								
Line regulation dV _{OUT} /dV _{IN}	From V _{IN} = 3.25 V to V _{IN} = 18 V		1	2.2	63		215	ppm/V
LOAD REGULATION								
Load regulation dV _{OUT} /dI _{LOAD}	–7 mA < I _{LOAD} < 10 mA, V _{IN} = 3.25 V		20	50	20		75	ppm/mA
SHORT-CIRCUIT CURRENT								
Short-circuit current I _{SC}	V _{OUT} = 0 V		25		11			mA
TEMP PIN								
Voltage output	At T _A = 25°C		575					mV
Temperature sensitivity ⁽³⁾			2.64					mV/°C
TURN-ON SETTLING TIME								
Turn-on settling time	To 0.1% with C _L = 1 μF		200					μs
POWER SUPPLY								
Supply voltage V _S		3.25		18	3.25		18	V
Quiescent current			0.8	1.2			1.5	mA
TEMPERATURE RANGE								
Specified range	–55°C to 210°C							
Operating range	–55°C to 210°C							

(1) Refer to Figure 5 of the TYPICAL CHARACTERISTICS.

(2) Refer to Figure 4 of the TYPICAL CHARACTERISTICS.

(3) Refer to Figure 10 of the TYPICAL CHARACTERISTICS.

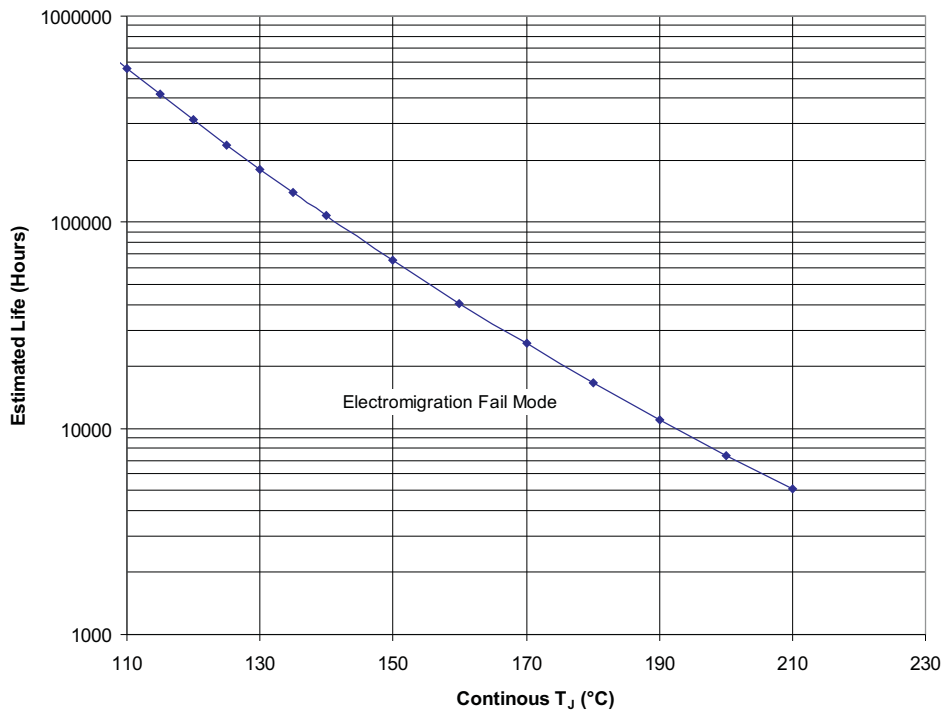

Figure 1. REF5025SKGD1 / REF5025SKGD2 Operating Life Derating Chart

Notes:

1. See datasheet for Absolute Maximum and minimum Recommended Operating Conditions.
2. Silicon operating life design goal is 10 years at 105°C junction temperature (does not include package interconnect life).

TYPICAL CHARACTERISTICS

$T_A = 25^\circ\text{C}$, $I_{\text{LOAD}} = 0$, $V_S = 3.25\text{ V}$ (unless otherwise noted).

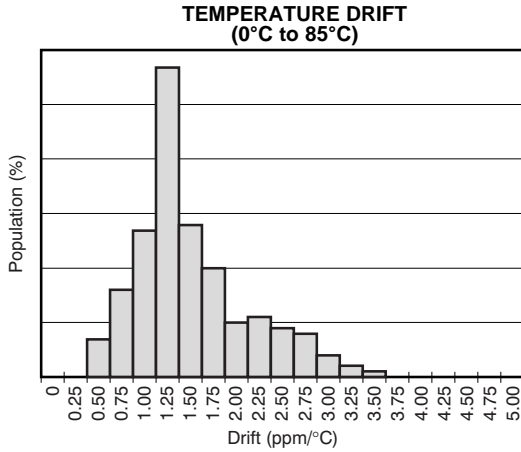

Figure 2.

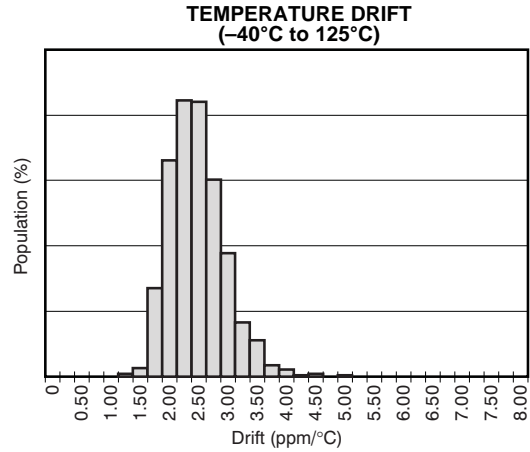

Figure 3.

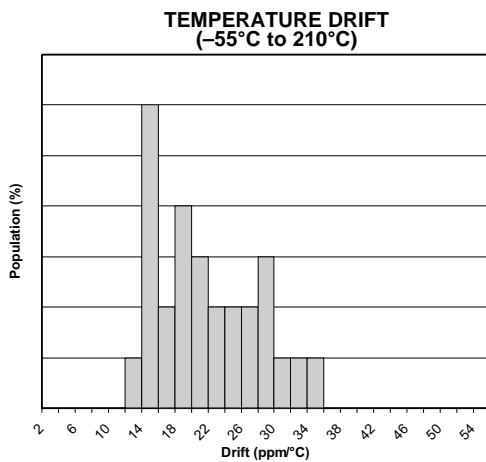

Figure 4.

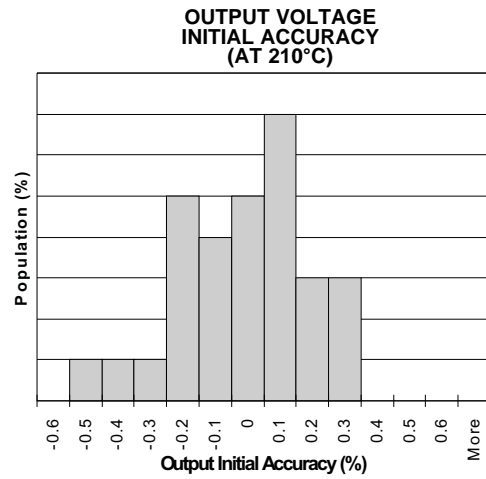

Figure 5.

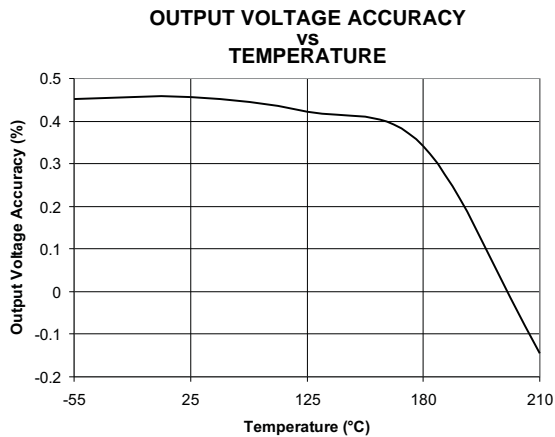

Figure 6.

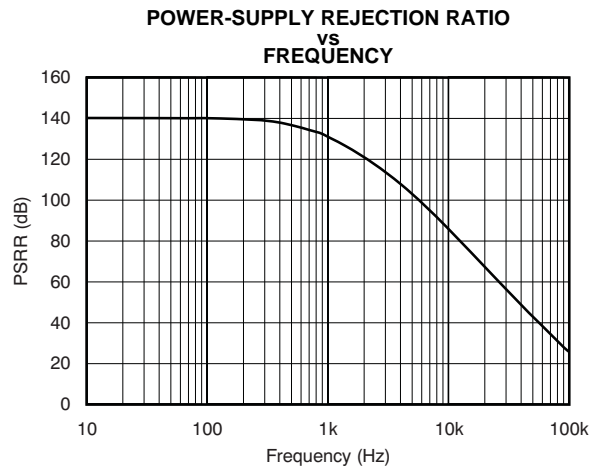

Figure 7.

TYPICAL CHARACTERISTICS (continued)

$T_A = 25^\circ\text{C}$, $I_{\text{LOAD}} = 0$, $V_S = 3.25\text{ V}$ (unless otherwise noted).

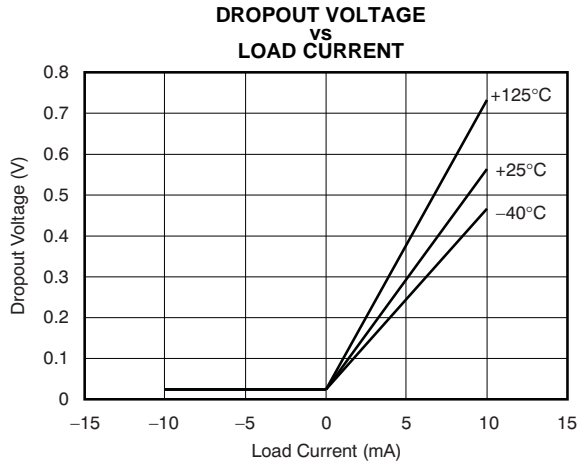

Figure 8.

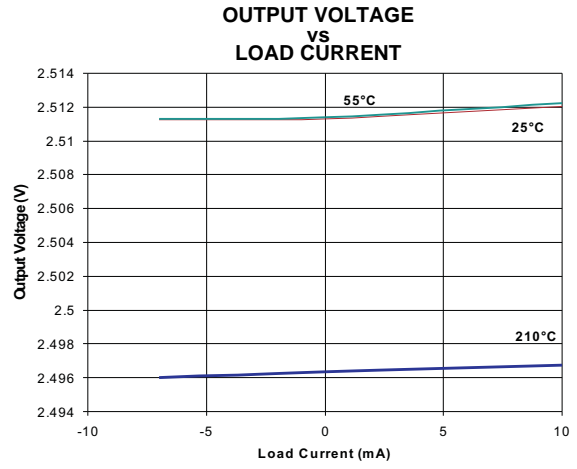

Figure 9.

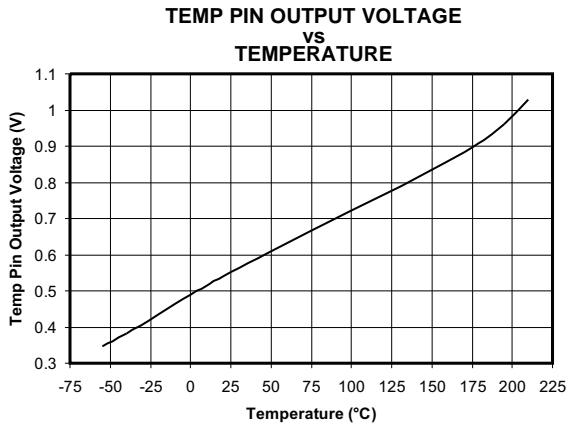

Figure 10.

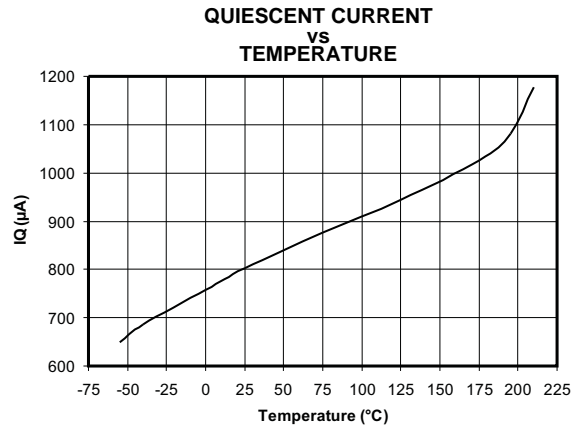

Figure 11.

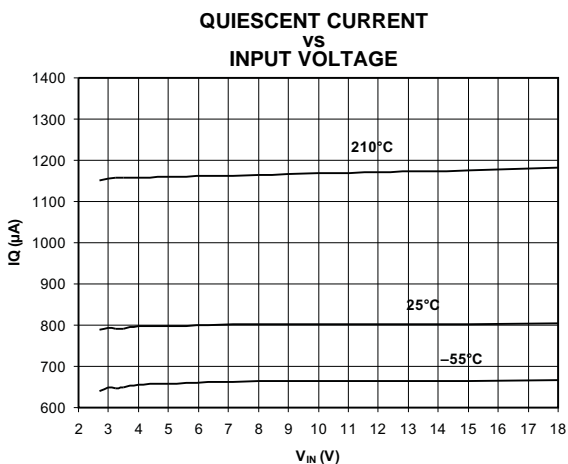

Figure 12.

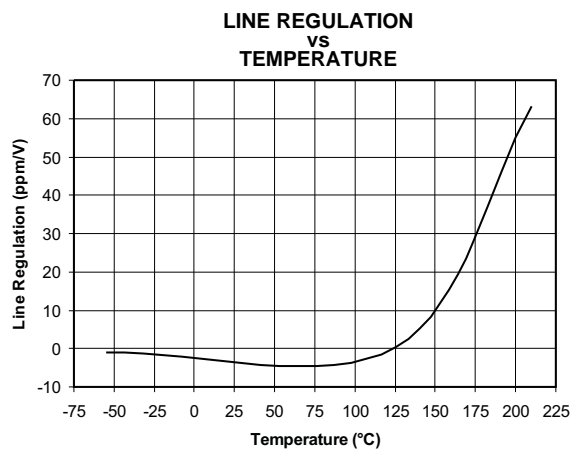

Figure 13.

TYPICAL CHARACTERISTICS (continued)

$T_A = 25^\circ\text{C}$, $I_{\text{LOAD}} = 0$, $V_S = 3.25\text{ V}$ (unless otherwise noted).

**SHORT-CIRCUIT CURRENT
vs
TEMPERATURE**

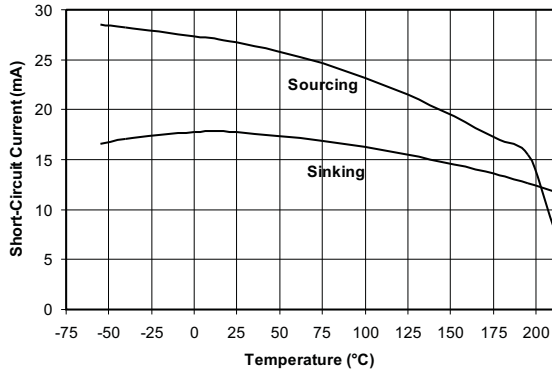

Figure 14.

NOISE

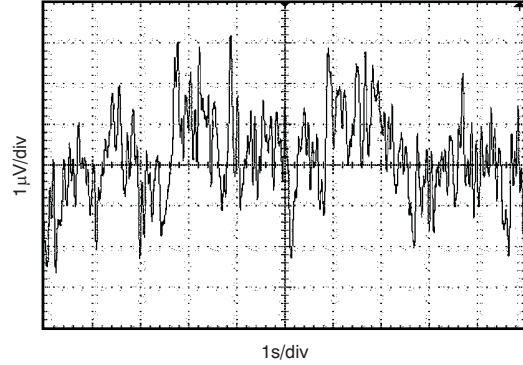

Figure 15.

**STARTUP
(REF5025, $C_L = 1\ \mu\text{F}$)**

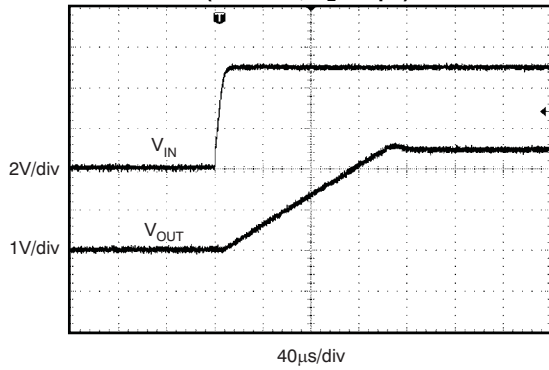

Figure 16.

**STARTUP
(REF5025, $C_L = 10\ \mu\text{F}$)**

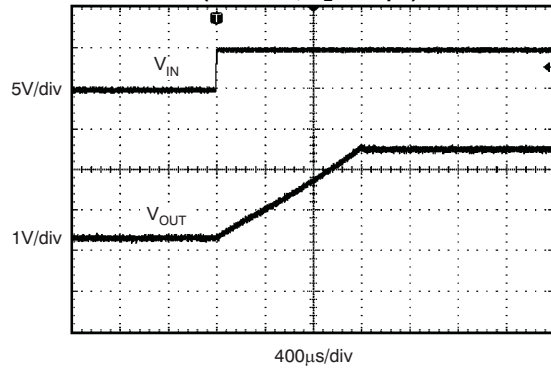

Figure 17.

**LOAD TRANSIENT
($C_L = 1\ \mu\text{F}$, $I_{\text{OUT}} = 1\ \text{mA}$)**

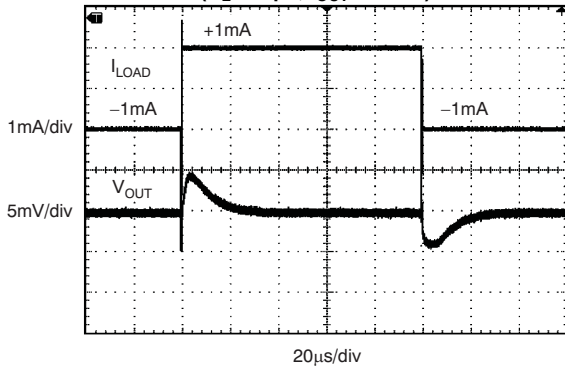

Figure 18.

**LOAD TRANSIENT
($C_L = 1\ \mu\text{F}$, $I_{\text{OUT}} = 10\ \text{mA}$)**

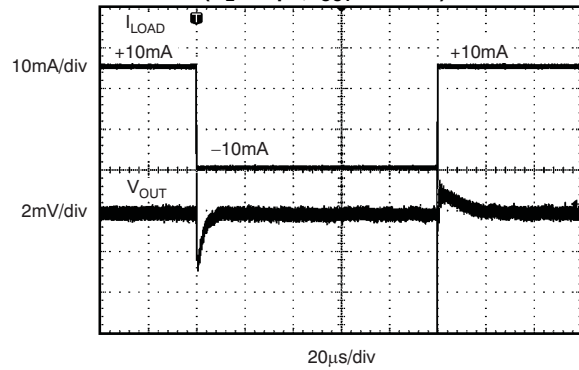
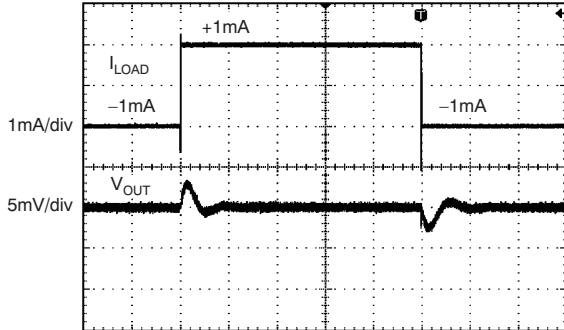

Figure 19.

TYPICAL CHARACTERISTICS (continued)

$T_A = 25^\circ\text{C}$, $I_{\text{LOAD}} = 0$, $V_S = 3.25\text{ V}$ (unless otherwise noted).

LOAD TRANSIENT
 $(C_L = 10\ \mu\text{F}, I_{\text{OUT}} = 1\ \text{mA})$



100 $\mu\text{s}/\text{div}$
Figure 20.

LOAD TRANSIENT
 $(C_L = 10\ \mu\text{F}, I_{\text{OUT}} = 10\ \text{mA})$

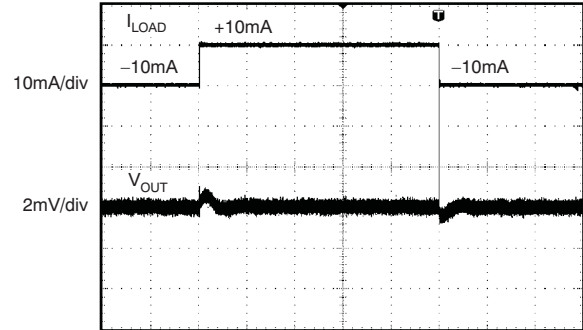

100 $\mu\text{s}/\text{div}$
Figure 21.

LINE TRANSIENT
 $(C_L = 1\ \mu\text{F})$

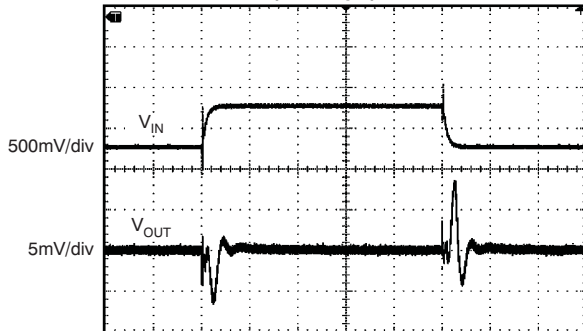

20 $\mu\text{s}/\text{div}$
Figure 22.

LINE TRANSIENT
 $(C_L = 10\ \mu\text{F})$

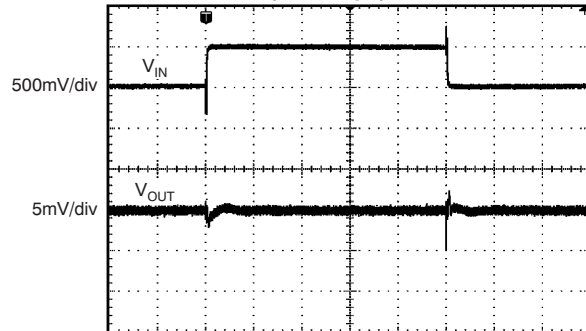

100 $\mu\text{s}/\text{div}$
Figure 23.

APPLICATION INFORMATION

The REF5025 is a low-noise, precision bandgap voltage reference that is specifically designed for excellent initial voltage accuracy and drift. Figure 24 shows a simplified block diagram of the REF5025.

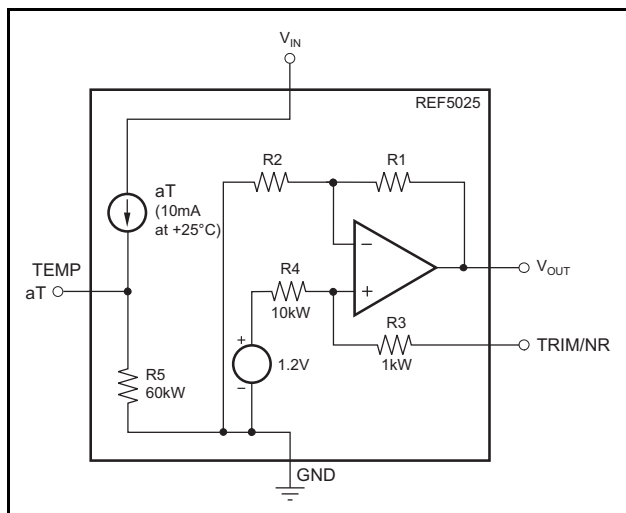

Figure 24. REF5025 Simplified Block Diagram

BASIC CONNECTIONS

Figure 25 shows the typical connections for the REF5025. A supply bypass capacitor ranging between 1 μF to 10 μF is recommended. A 1- μF to 50- μF , low-ESR output capacitor (C_L) must be connected from V_{OUT} to GND. The ESR value should be less than or equal to 1.5 Ω . The ESR minimizes gain peaking of the internal 1.2-V reference and thus reduces noise at the V_{OUT} pin.

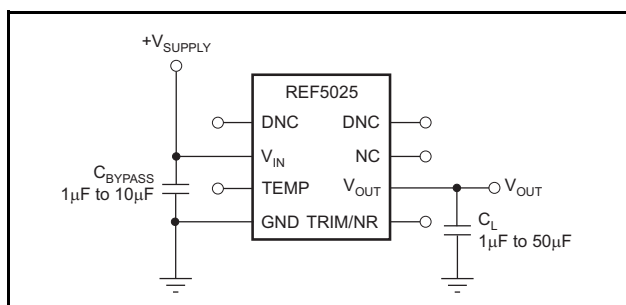

Figure 25. Basic Connections

SUPPLY VOLTAGE

The REF5025 features extremely low dropout voltage. For loaded conditions, a typical dropout voltage versus load plot is shown in Figure 8 of *Typical Characteristics*.

USING THE TRIM/NR PIN

The REF5025 provides a very accurate voltage output. However, V_{OUT} can be adjusted to reduce noise and shift the output voltage from the nominal value by configuring the trim and noise reduction pin (TRIM/NR, pin 5). The TRIM/NR pin provides a $\pm 15\text{-mV}$ adjustment of the device bandgap, which produces a $\pm 15\text{-mV}$ change on the V_{OUT} pin. Figure 26 shows a typical circuit using the TRIM/NR pin to adjust V_{OUT} . When using this technique, the temperature coefficients of the resistors can degrade the temperature drift at the output.

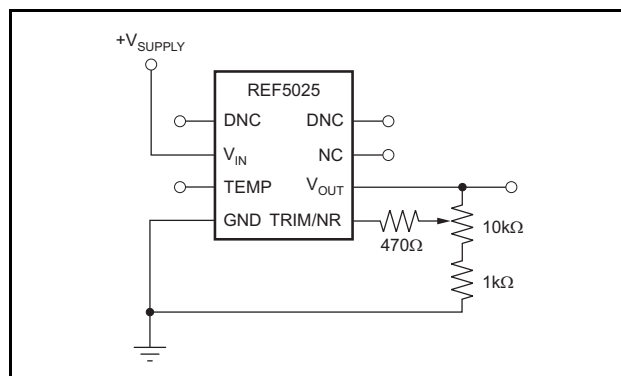

Figure 26. V_{OUT} Adjustment Using TRIM/NR Pin

The REF5025 allows access to the bandgap through the TRIM/NR pin. Placing a capacitor from the TRIM/NR pin to GND (as Figure 27 illustrates) in combination with the internal 1-k Ω resistor creates a low-pass filter that lowers the overall noise measured on the V_{OUT} pin. A capacitance of 1 μF is suggested for a low-pass filter with a corner frequency of 14.5 Hz. Higher capacitance results in a lower cutoff frequency.

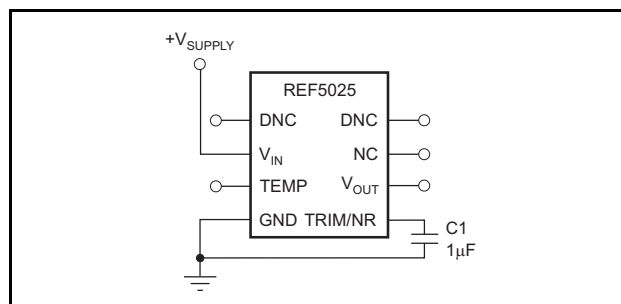

Figure 27. Noise Reduction Using TRIM/NR Pin

TEMPERATURE DRIFT

The REF5025 is designed for minimal drift error, which is defined as the change in output voltage over temperature. The drift is calculated using the box method, as described by the following equation:

$$\text{Drift} = \left(\frac{V_{\text{OUTMAX}} - V_{\text{OUTMIN}}}{V_{\text{OUT}} \times \text{Temp Range}} \right) \times 10^6 (\text{ppm}) \quad (1)$$

TEMPERATURE MONITORING

The temperature output terminal (TEMP, pin 3) provides a temperature-dependent voltage output with approximately 60-kΩ source impedance. As seen in Figure 10, the output voltage follows the nominal relationship:

$$V_{\text{TEMP PIN}} = 509 \text{ mV} + 2.64 \times T(^{\circ}\text{C}) \quad (2) \quad (2)$$

(For -55°C to 125°C only. Refer to Figure 10 of the TYPICAL CHARACTERISTICS for 125°C to 210°C .)

This pin indicates general chip temperature, accurate to approximately $\pm 15^{\circ}\text{C}$. Although it is not generally suitable for accurate temperature measurements, it can be used to indicate temperature changes or for temperature compensation of analog circuitry. A temperature change of 30°C corresponds to an approximate 79-mV change in voltage at the TEMP pin.

The TEMP pin has high output impedance (see Figure 24). Loading this pin with a low-impedance circuit induces a measurement error; however, it does not have any effect on V_{OUT} accuracy. To avoid errors caused by low-impedance loading, buffer the TEMP pin output with a suitable low-temperature drift op amp as shown in Figure 28.

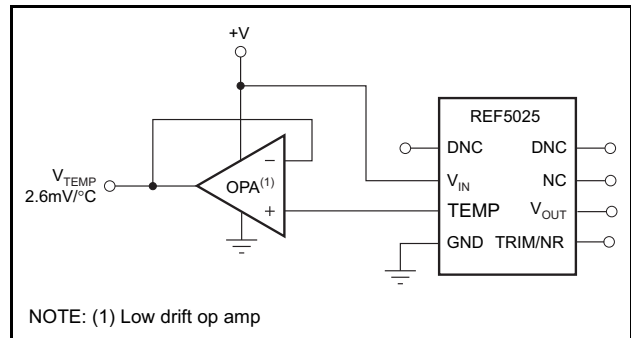

Figure 28. Buffering the TEMP Pin Output

POWER DISSIPATION

The REF5025 is specified to deliver current loads of $\pm 10 \text{ mA}$ over the specified input voltage range. The temperature of the device increases according to the equation:

$$T_J = T_A + P_D \times \theta_{JA} \quad (3) \quad (3)$$

Where:

T_J = Junction temperature ($^{\circ}\text{C}$)

T_A = Ambient temperature ($^{\circ}\text{C}$)

P_D = Power dissipated (W)

θ_{JA} = Junction-to-ambient thermal resistance ($^{\circ}\text{C}/\text{W}$)

The REF5025 junction temperature must not exceed the absolute maximum rating of 210°C .

NOISE PERFORMANCE

Typical 0.1-Hz to 10-Hz voltage noise for each member of the REF5025 is specified in the Electrical Characteristics table. The noise voltage increases with output voltage and operating temperature. Additional filtering can be used to improve output noise levels, although care should be taken to ensure the output impedance does not degrade performance.

APPLICATION CIRCUITS

NEGATIVE REFERENCE VOLTAGE

For applications requiring a negative and positive reference voltage, the REF5025 and OPA735 can be used to provide a dual-supply reference from a 5-V supply. Figure 29 shows the REF5025 used to provide a 2.5-V supply reference voltage. The low drift performance of the REF5025 complements the low offset voltage and zero drift of the OPA735 to provide an accurate solution for split-supply applications. Care must be taken to match the temperature coefficients of R₁ and R₂.

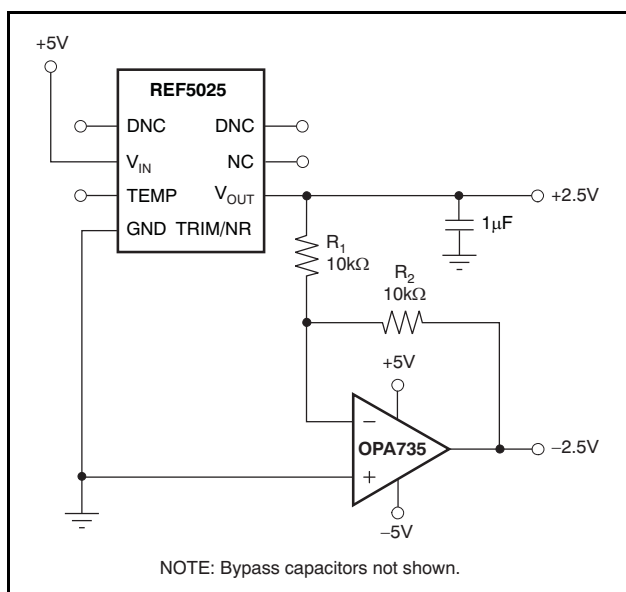

A. OPA735 has not been characterized or tested at 210°C.

Figure 29. The REF5025 and OPA735 Create Positive and Negative Reference Voltages

DATA ACQUISITION

Data acquisition systems often require stable voltage references to maintain accuracy. The REF5025 features low noise, very low drift, and high initial accuracy for high-performance data converters. Figure 30 shows the REF5025 in a basic data acquisition system.

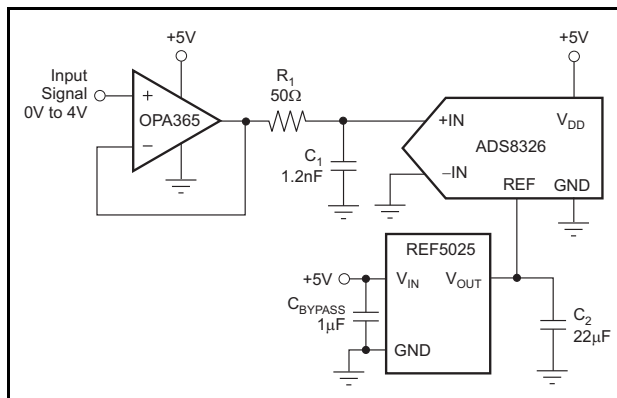

A. OPA365 and ADS8326 have not been characterized or tested at 210°C.

Figure 30. Basic Data Acquisition System

REVISION HISTORY

Changes from Revision D (April 2012) to Revision E	Page
• Added KGD2 package option	2

PACKAGING INFORMATION

Orderable Device	Status (1)	Package Type	Package Drawing	Pins	Package Qty	Eco Plan (2)	Lead/Ball Finish (6)	MSL Peak Temp (3)	Op Temp (°C)	Device Marking (4/5)	Samples
REF5025SHKJ	ACTIVE	CFP	HKJ	8	1	TBD	Call TI	N / A for Pkg Type	-55 to 210	REF5025S HKJ	Samples
REF5025SHKQ	ACTIVE	CFP	HKQ	8	25	TBD	AU	N / A for Pkg Type	-55 to 210	REF5025S HKQ	Samples
REF5025SKGD1	ACTIVE	XCEPT	KGD	0	195	TBD	Call TI	N / A for Pkg Type	-55 to 210		Samples
REF5025SKGD2	ACTIVE	XCEPT	KGD	0	10	TBD	Call TI	N / A for Pkg Type	-55 to 210		Samples

(1) The marketing status values are defined as follows:

ACTIVE: Product device recommended for new designs.

LIFEBUY: TI has announced that the device will be discontinued, and a lifetime-buy period is in effect.

NRND: Not recommended for new designs. Device is in production to support existing customers, but TI does not recommend using this part in a new design.

PREVIEW: Device has been announced but is not in production. Samples may or may not be available.

OBSELETE: TI has discontinued the production of the device.

(2) Eco Plan - The planned eco-friendly classification: Pb-Free (RoHS), Pb-Free (RoHS Exempt), or Green (RoHS & no Sb/Br) - please check <http://www.ti.com/productcontent> for the latest availability information and additional product content details.

TBD: The Pb-Free/Green conversion plan has not been defined.

Pb-Free (RoHS): TI's terms "Lead-Free" or "Pb-Free" mean semiconductor products that are compatible with the current RoHS requirements for all 6 substances, including the requirement that lead not exceed 0.1% by weight in homogeneous materials. Where designed to be soldered at high temperatures, TI Pb-Free products are suitable for use in specified lead-free processes.

Pb-Free (RoHS Exempt): This component has a RoHS exemption for either 1) lead-based flip-chip solder bumps used between the die and package, or 2) lead-based die adhesive used between the die and leadframe. The component is otherwise considered Pb-Free (RoHS compatible) as defined above.

Green (RoHS & no Sb/Br): TI defines "Green" to mean Pb-Free (RoHS compatible), and free of Bromine (Br) and Antimony (Sb) based flame retardants (Br or Sb do not exceed 0.1% by weight in homogeneous material)

(3) MSL, Peak Temp. - The Moisture Sensitivity Level rating according to the JEDEC industry standard classifications, and peak solder temperature.

(4) There may be additional marking, which relates to the logo, the lot trace code information, or the environmental category on the device.

(5) Multiple Device Markings will be inside parentheses. Only one Device Marking contained in parentheses and separated by a "-" will appear on a device. If a line is indented then it is a continuation of the previous line and the two combined represent the entire Device Marking for that device.

(6) Lead/Ball Finish - Orderable Devices may have multiple material finish options. Finish options are separated by a vertical ruled line. Lead/Ball Finish values may wrap to two lines if the finish value exceeds the maximum column width.



Important Information and Disclaimer: The information provided on this page represents TI's knowledge and belief as of the date that it is provided. TI bases its knowledge and belief on information provided by third parties, and makes no representation or warranty as to the accuracy of such information. Efforts are underway to better integrate information from third parties. TI has taken and continues to take reasonable steps to provide representative and accurate information but may not have conducted destructive testing or chemical analysis on incoming materials and chemicals. TI and TI suppliers consider certain information to be proprietary, and thus CAS numbers and other limited information may not be available for release.

In no event shall TI's liability arising out of such information exceed the total purchase price of the TI part(s) at issue in this document sold by TI to Customer on an annual basis.

OTHER QUALIFIED VERSIONS OF REF5025-HT :

- Catalog: [REF5025](#)
- Enhanced Product: [REF5025-EP](#)

NOTE: Qualified Version Definitions:

- Catalog - TI's standard catalog product
- Enhanced Product - Supports Defense, Aerospace and Medical Applications

MECHANICAL DATA

HKJ (R-CDFP-F8)

CERAMIC DUAL FLATPACK

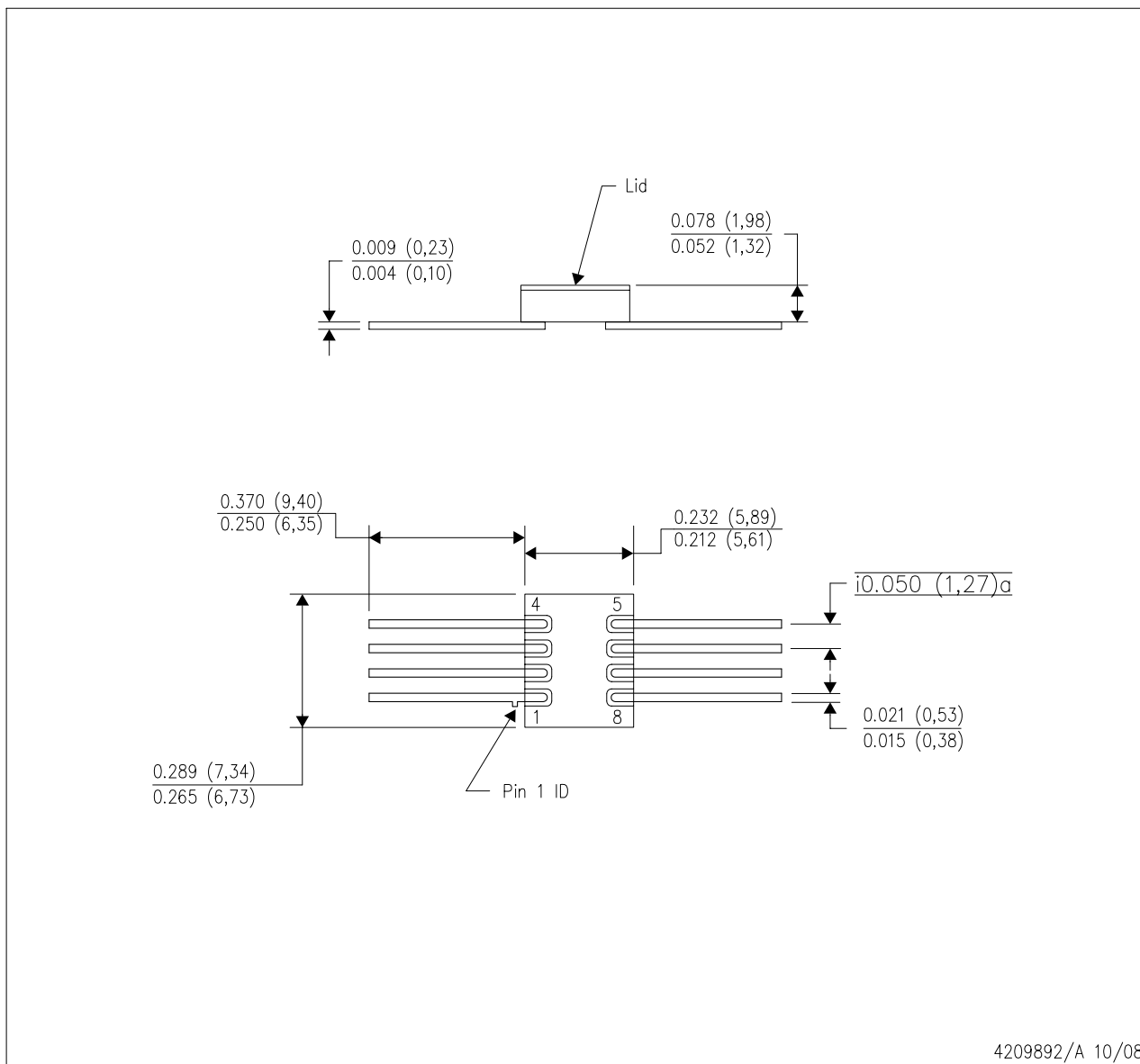

- NOTES:
- A. All linear dimensions are in inches (millimeters).
 - B. This drawing is subject to change without notice.
 - C. This package can be hermetically sealed with a metal lid.
 - D. The terminals will be gold plated.

MECHANICAL DATA

HKQ (R-CDFP-G8)

CERAMIC GULL WING

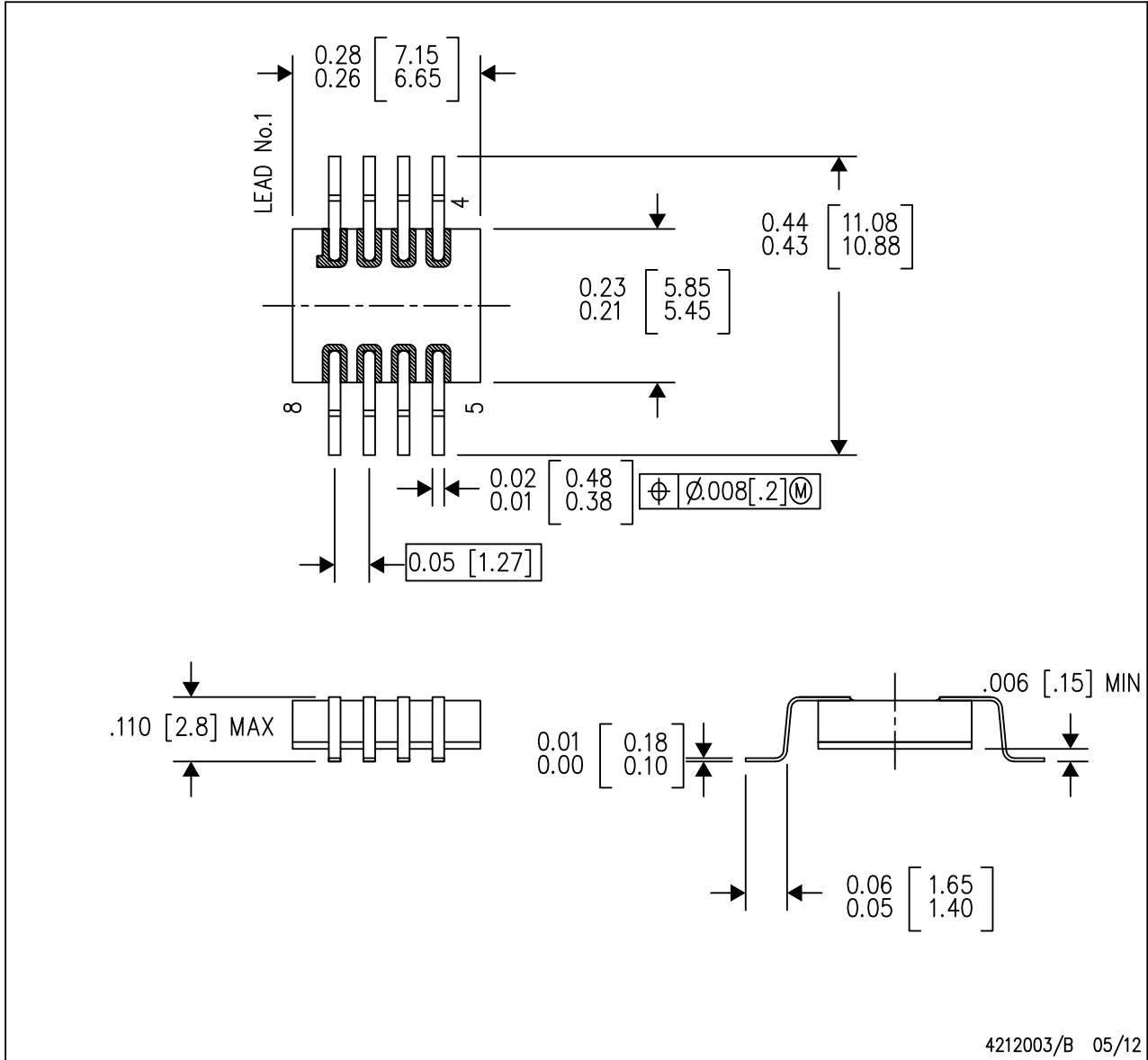

4212003/B 05/12

- NOTES:
- A. All linear dimensions are in inches (millimeters).
 - B. This drawing is subject to change without notice.
 - C. This package can be hermetically sealed with a metal lid.
 - D. The terminals will be gold plated.
 - E. Lid is not connected to any lead.

IMPORTANT NOTICE

Texas Instruments Incorporated and its subsidiaries (TI) reserve the right to make corrections, enhancements, improvements and other changes to its semiconductor products and services per JESD46, latest issue, and to discontinue any product or service per JESD48, latest issue. Buyers should obtain the latest relevant information before placing orders and should verify that such information is current and complete. All semiconductor products (also referred to herein as "components") are sold subject to TI's terms and conditions of sale supplied at the time of order acknowledgment.

TI warrants performance of its components to the specifications applicable at the time of sale, in accordance with the warranty in TI's terms and conditions of sale of semiconductor products. Testing and other quality control techniques are used to the extent TI deems necessary to support this warranty. Except where mandated by applicable law, testing of all parameters of each component is not necessarily performed.

TI assumes no liability for applications assistance or the design of Buyers' products. Buyers are responsible for their products and applications using TI components. To minimize the risks associated with Buyers' products and applications, Buyers should provide adequate design and operating safeguards.

TI does not warrant or represent that any license, either express or implied, is granted under any patent right, copyright, mask work right, or other intellectual property right relating to any combination, machine, or process in which TI components or services are used. Information published by TI regarding third-party products or services does not constitute a license to use such products or services or a warranty or endorsement thereof. Use of such information may require a license from a third party under the patents or other intellectual property of the third party, or a license from TI under the patents or other intellectual property of TI.

Reproduction of significant portions of TI information in TI data books or data sheets is permissible only if reproduction is without alteration and is accompanied by all associated warranties, conditions, limitations, and notices. TI is not responsible or liable for such altered documentation. Information of third parties may be subject to additional restrictions.

Resale of TI components or services with statements different from or beyond the parameters stated by TI for that component or service voids all express and any implied warranties for the associated TI component or service and is an unfair and deceptive business practice. TI is not responsible or liable for any such statements.

Buyer acknowledges and agrees that it is solely responsible for compliance with all legal, regulatory and safety-related requirements concerning its products, and any use of TI components in its applications, notwithstanding any applications-related information or support that may be provided by TI. Buyer represents and agrees that it has all the necessary expertise to create and implement safeguards which anticipate dangerous consequences of failures, monitor failures and their consequences, lessen the likelihood of failures that might cause harm and take appropriate remedial actions. Buyer will fully indemnify TI and its representatives against any damages arising out of the use of any TI components in safety-critical applications.

In some cases, TI components may be promoted specifically to facilitate safety-related applications. With such components, TI's goal is to help enable customers to design and create their own end-product solutions that meet applicable functional safety standards and requirements. Nonetheless, such components are subject to these terms.

No TI components are authorized for use in FDA Class III (or similar life-critical medical equipment) unless authorized officers of the parties have executed a special agreement specifically governing such use.

Only those TI components which TI has specifically designated as military grade or "enhanced plastic" are designed and intended for use in military/aerospace applications or environments. Buyer acknowledges and agrees that any military or aerospace use of TI components which have **not** been so designated is solely at the Buyer's risk, and that Buyer is solely responsible for compliance with all legal and regulatory requirements in connection with such use.

TI has specifically designated certain components as meeting ISO/TS16949 requirements, mainly for automotive use. In any case of use of non-designated products, TI will not be responsible for any failure to meet ISO/TS16949.

Products

Audio	www.ti.com/audio
Amplifiers	amplifier.ti.com
Data Converters	dataconverter.ti.com
DLP® Products	www.dlp.com
DSP	dsp.ti.com
Clocks and Timers	www.ti.com/clocks
Interface	interface.ti.com
Logic	logic.ti.com
Power Mgmt	power.ti.com
Microcontrollers	microcontroller.ti.com
RFID	www.ti-rfid.com
OMAP Applications Processors	www.ti.com/omap
Wireless Connectivity	www.ti.com/wirelessconnectivity

Applications

Automotive and Transportation	www.ti.com/automotive
Communications and Telecom	www.ti.com/communications
Computers and Peripherals	www.ti.com/computers
Consumer Electronics	www.ti.com/consumer-apps
Energy and Lighting	www.ti.com/energy
Industrial	www.ti.com/industrial
Medical	www.ti.com/medical
Security	www.ti.com/security
Space, Avionics and Defense	www.ti.com/space-avionics-defense
Video and Imaging	www.ti.com/video

TI E2E Community

e2e.ti.com