

Excellent Integrated System Limited

Stocking Distributor

Click to view price, real time Inventory, Delivery & Lifecycle Information:

[STMicroelectronics](#)
[STMUX1800EQTR](#)

For any questions, you can email us directly:

sales@integrated-circuit.com



STMUX1800E

16-bit to 8-bit MUX/DEMUX for gigabit Ethernet LAN switch
 with LED switch and enhanced ESD protection

Features

- Low R_{ON} : 4.0 Ω typical
- V_{CC} operating range: 3.0 to 3.6 V
- Enhanced ESD protection: > 8 kV (contact) and 15 kV (HBM)
- Low power mode for minimum power consumption
- Channel on capacitance: 9.5 pF typical
- Switching time speed: 9 ns
- Near to zero propagation delay: 250 ps
- Very low crosstalk: -45 dB at 250 MHz
- Bit-to-bit skew: 200 ps
- > 600 MHz -3 dB typical bandwidth (or data frequency)
- Three SPDT switches for LED support
- Rail-to-rail switching on data I/O ports (0 V to 5 V)
- Package: QFN42
- Lead-free

Applications

- 10/100/1000 Mbit Ethernet switching
- Audio/video switching

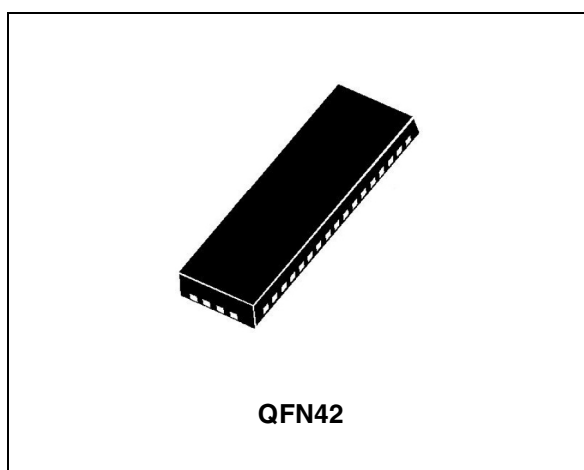

Description

The STMUX1800E is a 16 to 8-bit multiplexer/demultiplexer low R_{ON} bidirectional LAN switch designed for various standards, such as 10/100/1000 Ethernet. It is designed for very low crosstalk, low bit-to-bit skew and low I/O capacitance.

The differential signal from the Gigabit Ethernet transceiver is multiplexed into one of two selected outputs while the unselected switch goes to Hi-Z status.

The device integrates three SPDT (single pole dual throw) switches, for LED support.

The device can be put into low power mode consuming minimum power.

Table 1. Device summary

Order code	Package	Packing
STMUX1800EQTR	QFN42	Tape and reel

Contents

1	Pin description	5
2	Maximum rating	8
3	Electrical characteristics	9
4	Package mechanical data	20
5	Revision history	25

List of tables

Table 1.	Device summary	1
Table 2.	Pin description	5
Table 3.	LAN switch function table	7
Table 4.	LED switch function table	7
Table 5.	Absolute maximum ratings	8
Table 6.	Recommended operating conditions	8
Table 7.	DC electrical characteristics for Gigabit Ethernet LAN8/16MUX/DEMUX ($V_{CC} = 3.3\text{ V} \pm 10\%$)	9
Table 8.	DC electrical characteristics for 10/100 Ethernet LAN8/16MUX/DEMUX ($V_{CC} = 3.3\text{ V} \pm 10\%$)	11
Table 9.	Capacitance ($T_A = 25\text{ }^\circ\text{C}$, $f = 1\text{ MHz}$)	12
Table 10.	Power supply characteristics	12
Table 11.	Dynamic electrical characteristics ($V_{CC} = 3.3\text{ V} \pm 10\%$)	12
Table 12.	Switching characteristics ($T_A = 25\text{ }^\circ\text{C}$, $V_{CC} = 3.3\text{ V} \pm 10\%$)	13
Table 13.	ESD performance	13
Table 14.	Mechanical data for QFN42 (3.5 x 9 x 0.75) - pitch 0.5 mm	21
Table 15.	Document revision history	25

List of figures

Figure 1.	Pin connection (top through view)	5
Figure 2.	Input equivalent circuit	6
Figure 3.	Diagram for suggested V_{CC} decoupling	14
Figure 4.	Test circuit for leakage current (I_{OFF})	15
Figure 5.	Test circuit for SEL pin input capacitance (C_{IN})	15
Figure 6.	Test circuit for switch off capacitance (C_{OFF})	16
Figure 7.	Test circuit for switch on capacitance (C_{ON})	16
Figure 8.	Test circuit for bandwidth measurement (BW)	17
Figure 9.	Test circuit for crosstalk measurement (x_{talk})	18
Figure 10.	Test circuit for off isolation measurement (O_{IRR})	19
Figure 11.	Package outline for QFN42 (3.5 x 9 x 0.75) - pitch 0.5 mm	20
Figure 12.	Footprint recommendation for QFN42 (3.5 x 9 x 0.75) - pitch 0.5 mm	22
Figure 13.	Carrier tape information for QFN42 (3.5 x 9 x 0.75) - pitch 0.5 mm	23
Figure 14.	Reel information for QFN42 (3.5 x 9 x 0.75) - pitch 0.5 mm	24

1 Pin description

Figure 1. Pin connection (top through view)

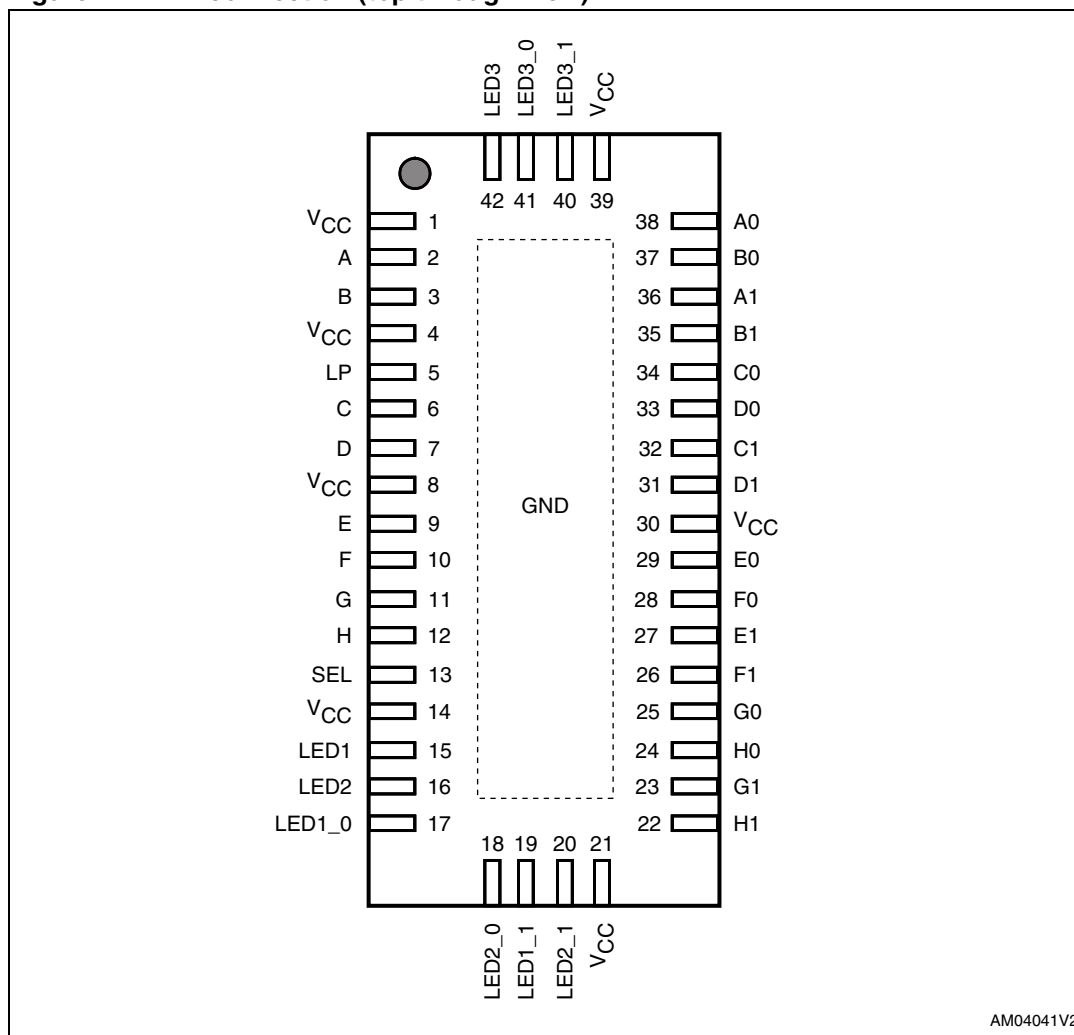

Table 2. Pin description

Pin	Symbol	Name and function
2, 3, 6, 7, 9, 10, 11, 12	A, B, C, D, E, F, G, H	8-bit bus
38, 37, 34, 33, 29, 28, 25, 24	A0, B0, C0, D0, E0, F0, G0, H0	8-bit multiplexed to bus 0
36, 35, 32, 31, 27, 26, 23, 22	A1, B1, C1, D1, E1, F1, G1, H1	8-bit multiplexed to bus 1
5	LP	Low power mode enable
13	SEL	Bus and LED switch selection
15, 16, 42	LED1, LED2, LED3	LED switch input
17, 18, 41, 19, 20, 40	LED1_0, LED2_0, LED3_0, LED1_1, LED2_1, LED3_1	LED switch output
1, 4, 8, 14, 21, 30, 39	V _{CC}	Supply voltage

Pin description

STMUX1800E

Figure 2. Input equivalent circuit

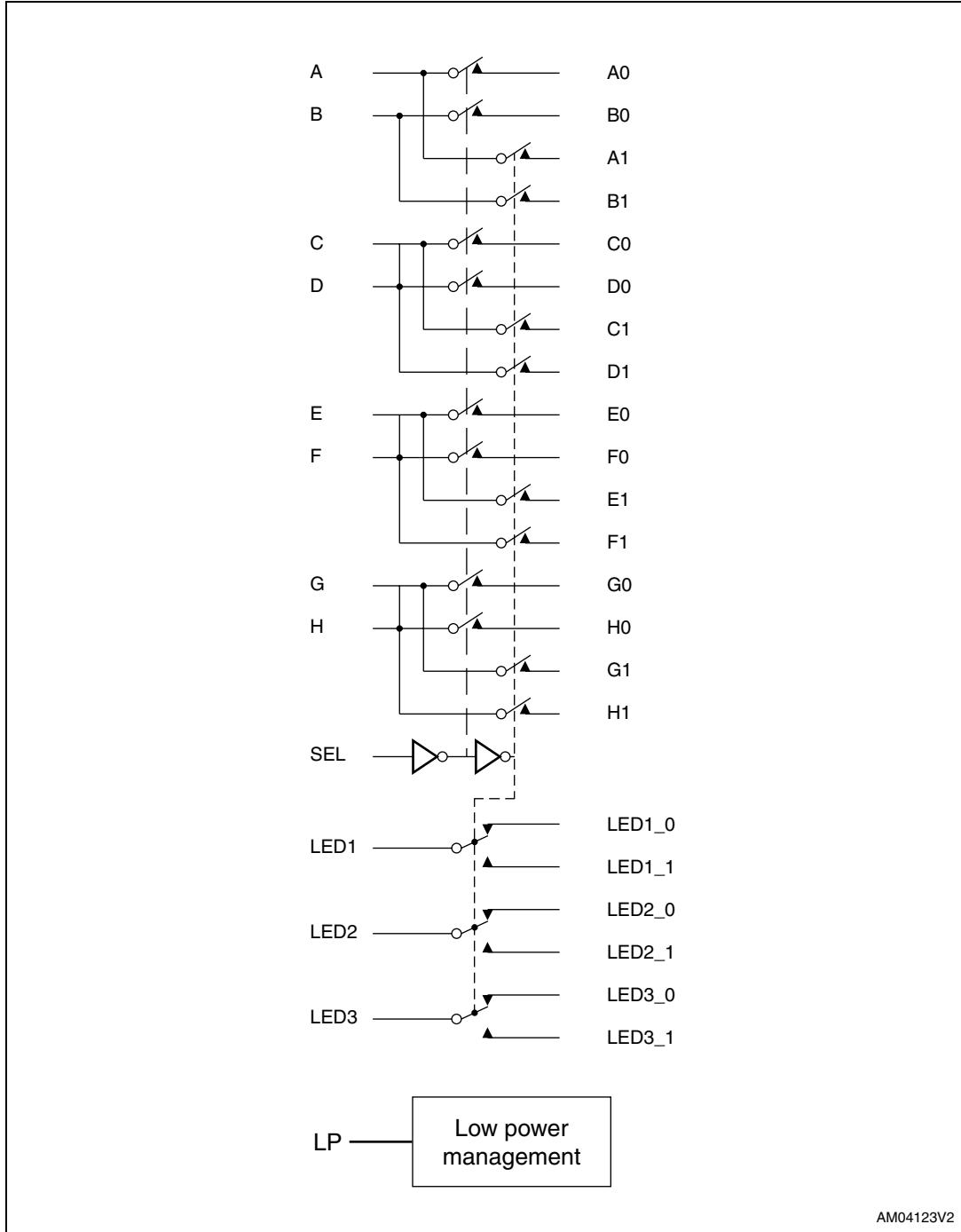

AM04123V2

STMUX1800E

Pin description

Table 3. LAN switch function table

LP	SEL	Function
L	L	8-bit bus to 8-bit multiplexed bus 0
L	H	8-bit bus to 8-bit multiplexed bus 1
H	X	Bus 0 and 1 in Hi-Z

Table 4. LED switch function table

LP	SEL	Function
L	L	LED switch input connected to LED switch output X_0
L	H	LED switch input connected to LED switch output X_1
H	X	Output X_0 and X_1 in Hi-Z

2 Maximum rating

Stressing the device above the rating listed in [Table 5: Absolute maximum ratings](#) may cause permanent damage to the device. These are stress ratings only and operation of the device at these or any other conditions above those indicated in [Table 6: Recommended operating conditions](#) of this specification is not implied. Exposure to absolute maximum rating conditions for extended periods may affect device reliability.

Table 5. Absolute maximum ratings

Symbol	Parameter	Value	Unit
V _{CC}	Supply voltage to ground	-0.5 to 4.6	V
V _{IO}	DC input output voltage	-0.5 to 4.6	V
V _{IC}	DC control input voltage	-0.5 to 4.6	V
I _O	DC output current ⁽¹⁾	120	mA
P _D	Power dissipation	0.5	W
T _{stg}	Storage temperature	-65 to 150	°C
T _L	Lead temperature (10 seconds)	300	°C

1. If V_{IO} × I_O does not exceed the maximum limit of P_D.

Recommended operating conditions

Table 6. Recommended operating conditions

Symbol	Parameter	Value			Unit
		Min.	Typ.	Max.	
V _{CC}	Supply voltage to ground	3	—	3.6	V
V _{IC}	DC control input voltage (SEL, LP)	0	—	V _{CC}	V
V _{IO}	DC input/output voltage	0	—	V _{CC}	V
T _A	Operating temperature	-40	—	85	°C

STMUX1800E

Electrical characteristics

3 Electrical characteristics

Table 7. DC electrical characteristics for Gigabit Ethernet LAN8/16MUX/DEMUX
 ($V_{CC} = 3.3\text{ V} \pm 10\%$)

Symbol	Parameter	Test condition	Value			Unit
			-40 to 85 °C			
			Min.	Typ.	Max.	
V_{IH}	Voltage input high (SEL, LP)	High level guaranteed	2.4	—	—	V
V_{IL}	Voltage input low (SEL, LP)	Low level guaranteed	-0.5	—	0.8	V
V_{IK}	Clamp diode voltage (SEL, LP)	$V_{CC} = 3.6\text{ V}$ $I_{IN} = -18\text{ mA}$	—	-0.8	-1.2	V
I_{IH}	Input high current (SEL, LP)	$V_{CC} = 3.6\text{ V}$ $V_{IN} = V_{CC}$	—	—	± 5	μA
I_{IL}	Input low current (SEL, LP)	$V_{CC} = 3.6\text{ V}$ $V_{IN} = \text{GND}$	—	—	± 5	μA
$I_{OFF(SW)}^{(1)}$	Leakage current through the switch common terminals (A to H) (LED1 to LED3)	$V_{CC} = 3.6\text{ V}$ A to H = V_{CC} LED1 to LED3 = V_{CC} A0 to H0 = 0 V A1 to H1 = floating LEDx_0 = 0 V LEDx1 = floating SEL = V_{CC} LP = GND	—	—	± 1	μA
$I_{off(sw_LP)}$	Leakage current through the switch in LP mode	$V_{CC} = 3.6\text{ V}$; A to H = V_{CC} ; LED1 to LED3 = V_{CC} ; A0 to H0, A1 to H1 = 0V; LEDx_0, LEDx_1 = 0V LP = V_{CC}			± 10	μA
$I_{OFF(SEL)}$	SEL pin leakage current	$V_{CC} = 0\text{ V}$ SEL = 0 to 3.6 V	—	—	± 1	μA
R_{ON}	Switch ON resistance ⁽²⁾	$V_{CC} = 3.0\text{ V}$ $V_{IN} = 1.5\text{ to }V_{CC}$ $I_{IN} = -40\text{ mA}$	—	4.0	6.5	Ω

Electrical characteristics

STMUX1800E

Table 7. DC electrical characteristics for Gigabit Ethernet LAN8/16MUX/DEMUX (V_{CC} = 3.3 V ±10%) (continued)

Symbol	Parameter	Test condition	Value			Unit
			-40 to 85 °C			
			Min.	Typ.	Max.	
R _{FLAT}	ON resistance flatness ^{(2), (3)}	V _{CC} = 3.0 V V _{IN} at 1.5 and V _{CC} I _{IN} = -40 mA	—	0.5	—	Ω
ΔR _{ON}	ON resistance match between channel ΔR _{ON} = R _{ONMAX} - R _{ONMIN} ^{(2), (4)}	V _{CC} = 3.0 V V _{IN} = 1.5 to V _{CC} I _{IN} = -40 mA	—	0.4	1	Ω

1. Refer to [Figure 4: Test circuit for leakage current \(I_{OFF}\) on page 15](#).
2. Measured by voltage drop between channels at indicated current through the switch. ON resistance is determined by the lower of the voltages.
3. Flatness is defined as the difference between the R_{ONMAX} and R_{ONMIN} of ON resistance over the specified range.
4. ΔR_{ON} measured at the same V_{CC}, temperature and voltage level.

STMUX1800E

Electrical characteristics

Table 8. DC electrical characteristics for 10/100 Ethernet LAN8/16MUX/DEMUX (V_{CC} = 3.3 V ±10)

Symbol	Parameter	Test condition	Value			Unit
			-40 to 85 °C			
			Min.	Typ.	Max.	
V _{IH}	Voltage input high (SEL, LP)	High level guaranteed	2.4	—	—	V
V _{IL}	Voltage input low (SEL, LP)	Low level guaranteed	-0.5	—	0.8	V
V _{IK}	Clamp diode voltage (SEL, LP)	V _{CC} = 3.6 V I _{IN} = -18 mA	—	-0.7	-1.2	V
I _{IH}	Input high current (SEL, LP)	V _{CC} = 3.6 V V _{IN} = V _{CC}	—	—	±5	µA
I _{IL}	Input low current (SEL, LP)	V _{CC} = 3.6 V V _{IN} = GND	—	—	±5	µA
I _{OFF(SW)} ⁽¹⁾	Leakage current through the switch common terminals (A to H) (LED1 to LED3)	V _{CC} = 3.6 V A to H = V _{CC} LED1 to LED3 = V _{CC} A0 to H0 = 0 V A1 to H1 = floating LEDx_0 = 0 V LEDx1 = floating SEL = V _{CC} LP = GND	—	—	±1	µA
I _{off(sw_LP)}	Leakage current through the switch in LP mode	V _{CC} = 3.6 V; A to H = V _{CC} ; LED1 to LED3 = V _{CC} ; A0 to H0, A1 to H1 = 0 V; LEDx_0, LEDx_1 = 0 V LP = V _{CC}			±10	µA
I _{OFF(SEL)}	SEL pin leakage current	V _{CC} = 0 V SEL = 0 to 3.6 V	—	—	±1	µA
R _{ON}	Switch ON resistance ⁽²⁾	V _{CC} = 3.0 V V _{IN} = 1.5 to V _{CC} I _{IN} = -10 to -30 mA	—	4.0	6.5	Ω
R _{FLAT}	ON resistance flatness ^{(2) (3)}	V _{CC} = 3.0 V V _{IN} at 1.5 and V _{CC} I _{IN} = -10 to -30 mA	—	0.5	—	Ω
ΔR _{ON}	ON resistance match between channel ΔR _{ON} = R _{ONMAX} - R _{ONMIN} ⁽²⁾⁽⁴⁾	V _{CC} = 3.0 V V _{IN} = 1.5 to V _{CC} I _{IN} = -10 to -30 mA	—	0.4	1	Ω

1. Refer to [Figure 4: Test circuit for leakage current \(I_{OFF}\) on page 15.](#)
2. Measured by voltage drop between channels at indicated current through the switch. ON resistance is determined by the lower of the two voltages.
3. Flatness is defined as the difference between the R_{ONMAX} and R_{ONMIN} of ON resistance over the specified range.
4. ΔR_{ON} measured at the same V_{CC}, temperature and voltage level.

Electrical characteristics

STMUX1800E

Table 9. Capacitance ($T_A = 25\text{ }^\circ\text{C}$, $f = 1\text{ MHz}$)

Symbol	Parameter	Test condition	Value			Unit
			Min.	Typ.	Max.	
C_{IN}	SEL pin input capacitance ⁽¹⁾	DC = 0.25 V AC = 0.5 V _{PP} f = 1 MHz	—	2	3	pF
C_{OFF}	Switch off capacitance ⁽²⁾	DC = 0.25 V AC = 0.5 V _{PP} f = 1 MHz	—	4	5	pF
C_{ON}	Switch on capacitance ⁽³⁾	DC = 0.25 V AC = 0.5 V _{PP} f = 1 MHz	—	9.5	11	pF

1. Refer to [Figure 5: Test circuit for SEL pin input capacitance \(\$C_{IN}\$ \) on page 15.](#)
2. Refer to [Figure 6: Test circuit for switch off capacitance \(\$C_{OFF}\$ \) on page 16.](#)
3. Refer to [Figure 7: Test circuit for switch on capacitance \(\$C_{ON}\$ \) on page 16.](#)

Table 10. Power supply characteristics

Symbol	Parameter	Test condition	Value			Unit
			-40 to 85 °C			
			Min.	Typ.	Max.	
I_{CC}	Active mode power supply current	$V_{CC} = 3.6\text{ V}$, $V_{IN} = V_{CC}$ or GND, LP = GND	—	150	500	μA
	Low power mode power supply current	$V_{CC} = 3.6\text{ V}$, $V_{IN} = V_{CC}$ or GND, LP = V_{CC}	—	10	50	μA

Table 11. Dynamic electrical characteristics ($V_{CC} = 3.3\text{ V} \pm 10\%$)

Symbol	Parameter	Test condition	Value			Unit
			-40 to 85 °C			
			Min.	Typ.	Max.	
X_{talk}	Crosstalk ⁽¹⁾	$R_L = 100\ \Omega$ f = 250 MHz	—	-45	—	dB
O_{IRR}	Off isolation ⁽²⁾	$R_L = 100\ \Omega$ f = 250 MHz	—	-37	—	dB
BW	-3 dB bandwidth ⁽³⁾	$R_L = 100\ \Omega$ $0 < V_{IN} \leq 3.6\text{ V}$	—	600	—	MHz

1. Refer to [Figure 9: Test circuit for crosstalk measurement \(\$X_{talk}\$ \) on page 18.](#)
2. Refer to [Figure 10: Test circuit for off isolation measurement \(\$O_{IRR}\$ \) on page 19.](#)
3. Refer to [Figure 8: Test circuit for bandwidth measurement \(BW\) on page 17.](#)

STMUX1800E

Electrical characteristics

Table 12. Switching characteristics ($T_A = 25\text{ }^\circ\text{C}$, $V_{CC} = 3.3\text{ V} \pm 10\%$)

Symbol	Parameter	Test condition	Value			Unit
			Min.	Typ.	Max.	
t_{PD}	Propagation delay	$V_{CC} = 3\text{ to }3.6\text{ V}$	—	0.25	—	ns
t_{PZH} , t_{PZL}	Line enable time, SE to x to x0 or x to x1	$V_{CC} = 3\text{ to }3.6\text{ V}$	0.5	6.5	15	ns
t_{PHZ} , t_{PLZ}	Line disable time, SE to x to x0 or x to x1	$V_{CC} = 3\text{ to }3.6\text{ V}$	0.5	6.5	8.5	ns
$t_{SK(O)}$	Output skew between center port to any other port	$V_{CC} = 3\text{ to }3.6\text{ V}$	—	0.1	0.2	ns
$t_{SK(P)}$	Skew between opposite transition of the same output (t_{PHL} , t_{PLH})	$V_{CC} = 3\text{ to }3.6\text{ V}$	—	0.1	0.2	ns

Table 13. ESD performance

Symbol	Test condition	Value			Unit
		Min.	Typ.	Max.	
ESD	Contact discharge ⁽¹⁾ IEC61000-4-2	—	±8	—	kV
	Human body model (MIL-STD-883)	—	±15	—	kV

1. Refer to [Figure 3: Diagram for suggested \$V_{CC}\$ decoupling on page 14.](#)

Electrical characteristics

STMUX1800E

Figure 3. Diagram for suggested V_{CC} decoupling

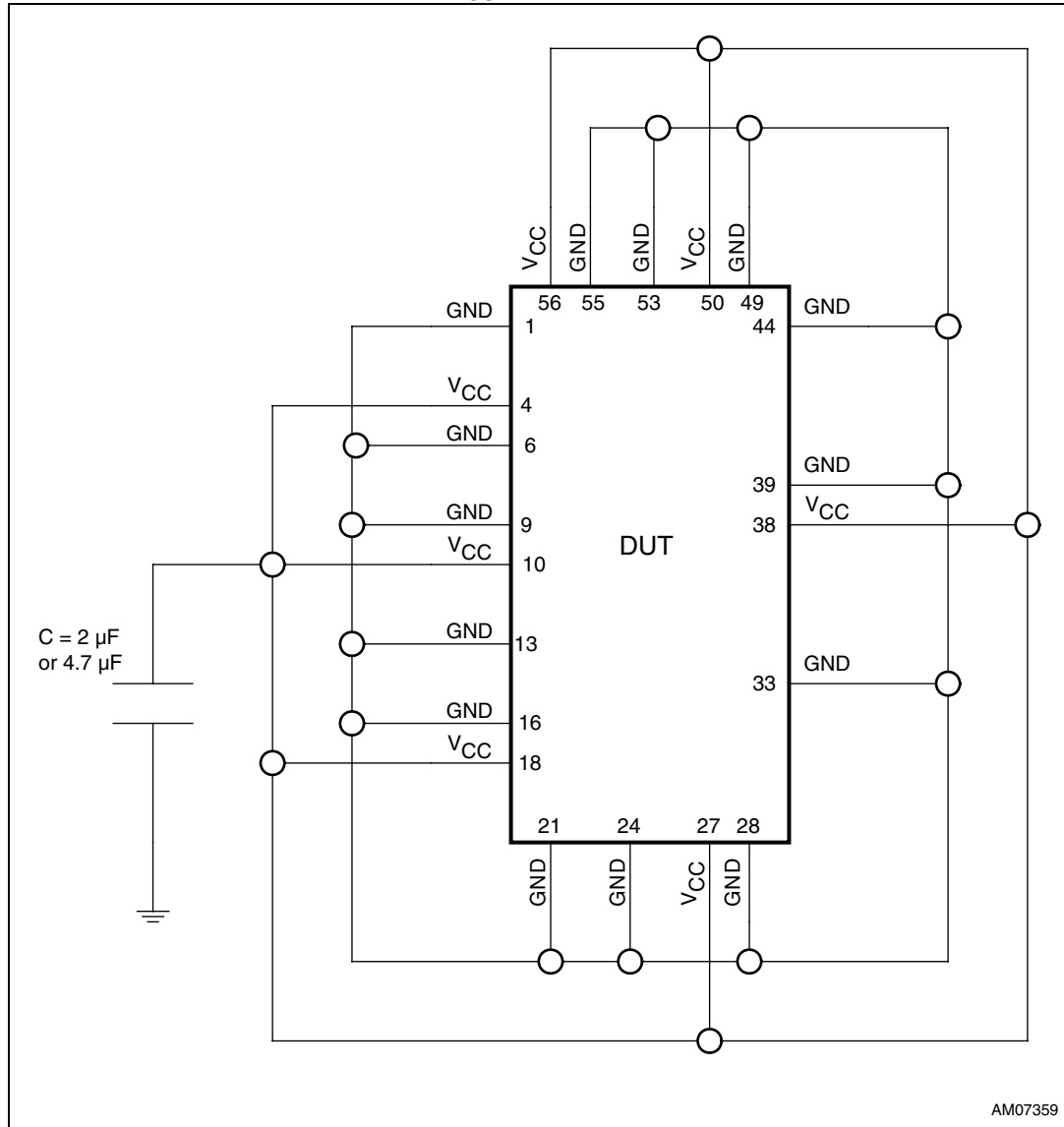

1. Applicable for system level ESD test.
2. 100 nF capacitors must be used as local bypass capacitors between the adjacent V_{CC} and GND pairs (total 7).

STMUX1800E

Electrical characteristics

Figure 4. Test circuit for leakage current (I_{OFF})

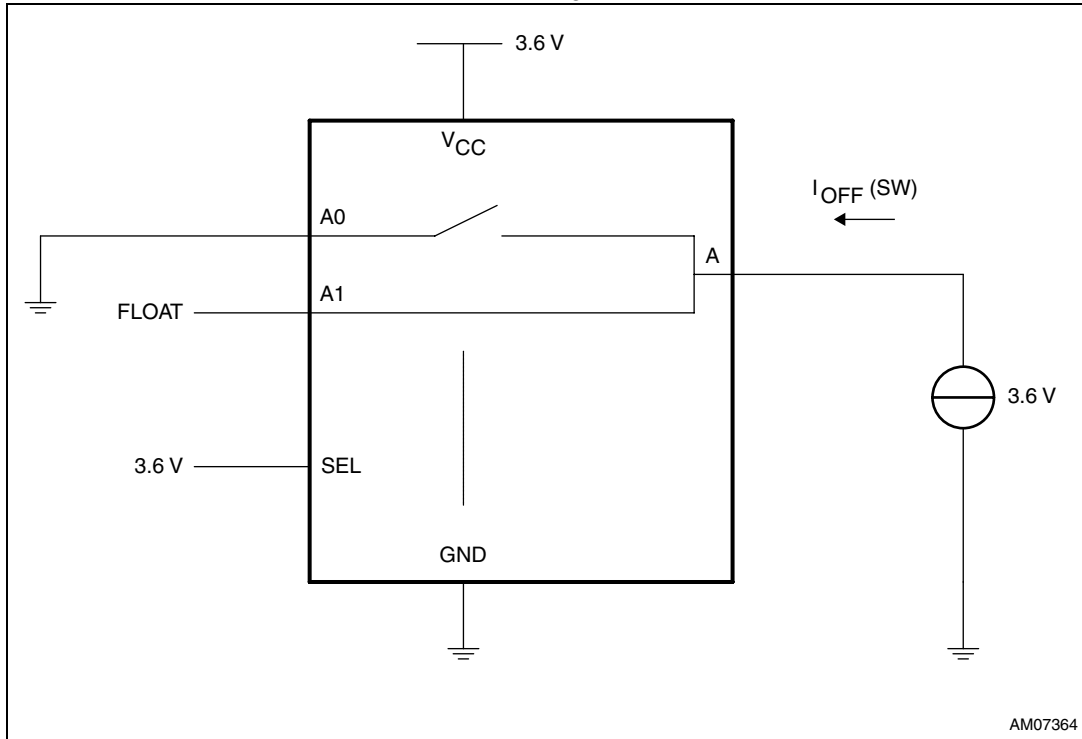
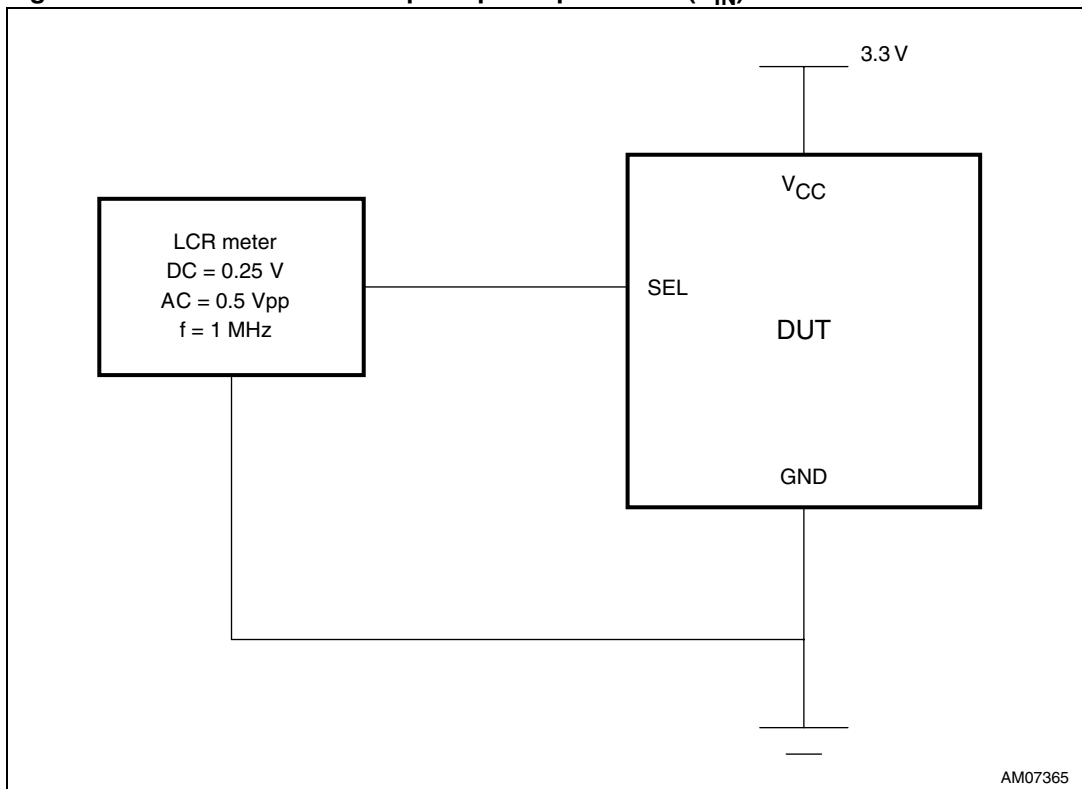

Figure 5. Test circuit for SEL pin input capacitance (C_{IN})



Electrical characteristics

STMUX1800E

Figure 6. Test circuit for switch off capacitance (C_{OFF})

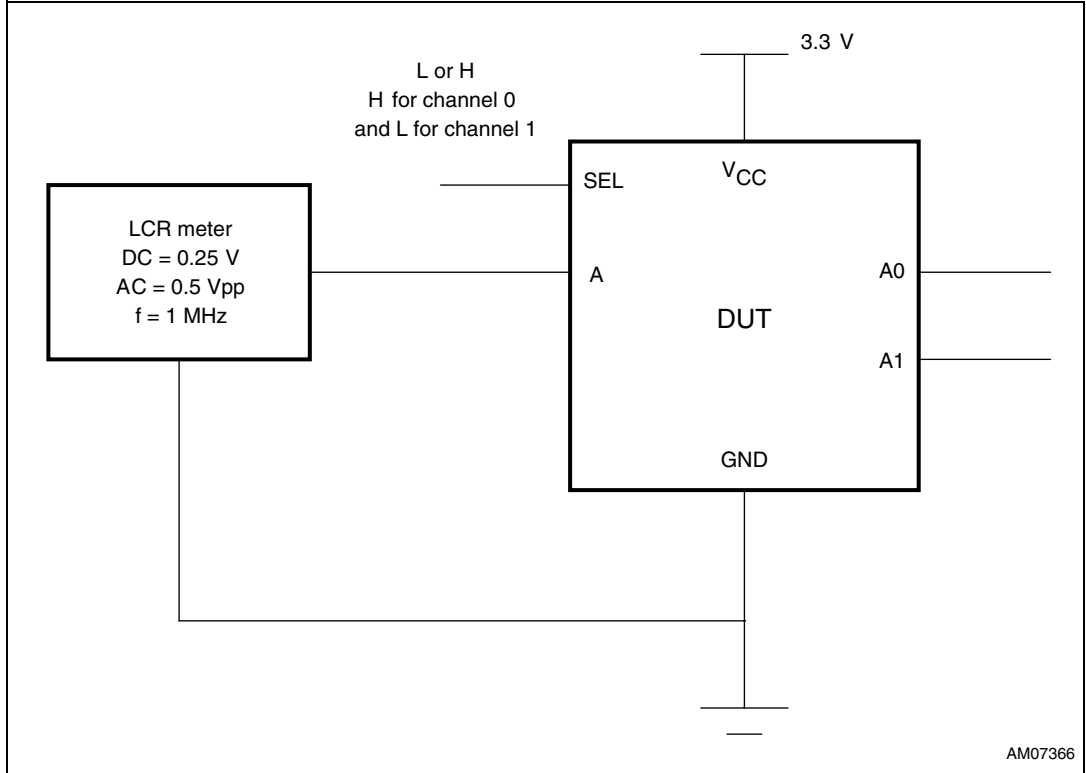
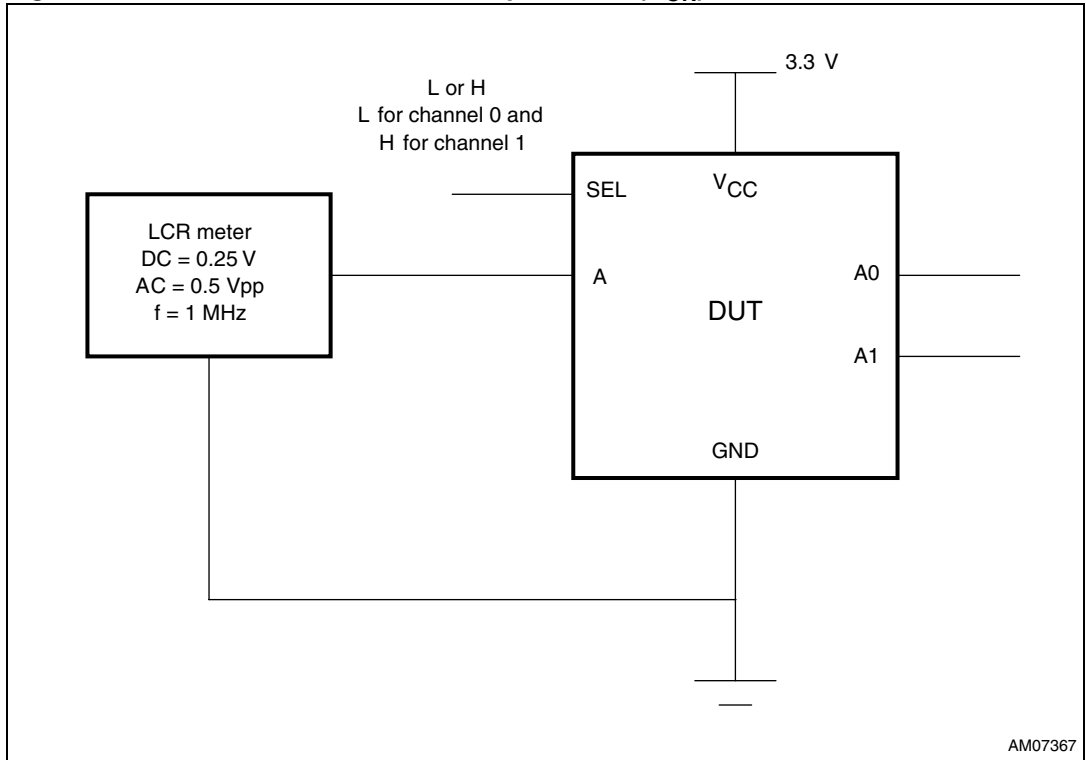

Figure 7. Test circuit for switch on capacitance (C_{ON})



STMUX1800E

Electrical characteristics

Figure 8. Test circuit for bandwidth measurement (BW)

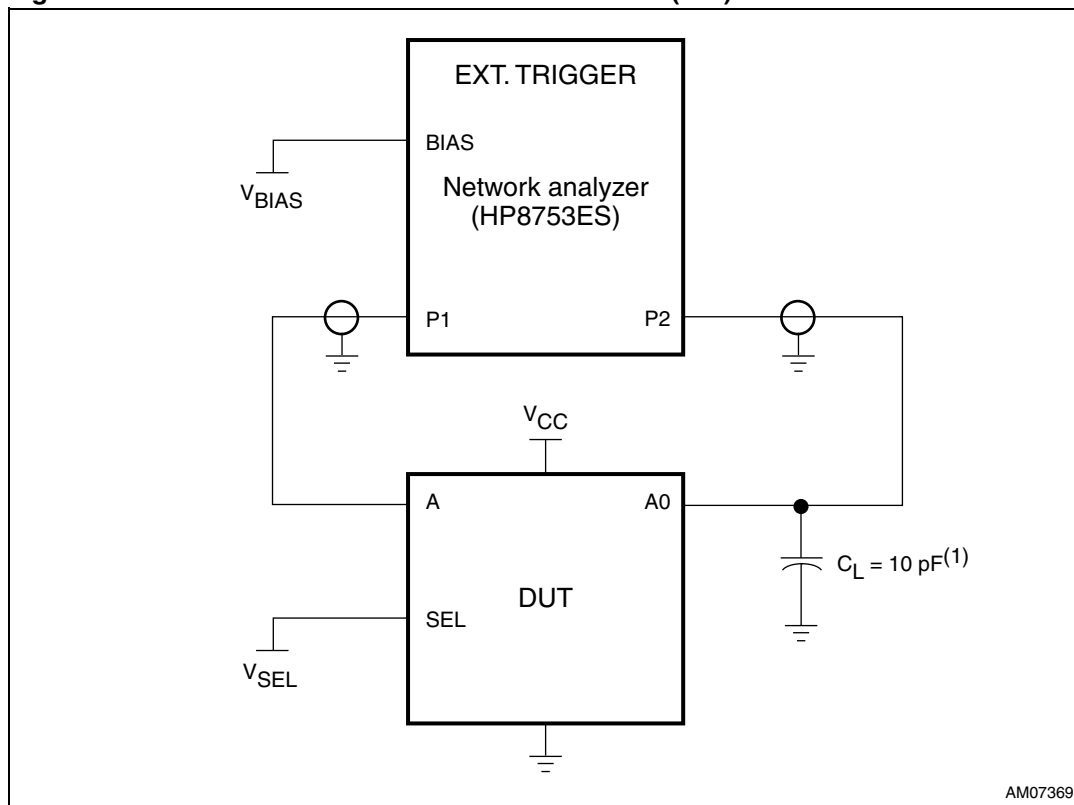

1. C_L includes probe and jig capacitance.

Frequency response is measured at the output of the ON channel. For example, when $V_{SEL} = 0$ and A is the input, the output is measured at A0. All unused analog I/O ports are left open.

HP8753ES setup:

Average = 4

$R_{BW} = 3 \text{ kHz}$

$V_{BIAS} = 0.35 \text{ V}$

ST = 2 s

P1 = 0 dBm

Electrical characteristics

STMUX1800E

Figure 9. Test circuit for crosstalk measurement (x_{talk})

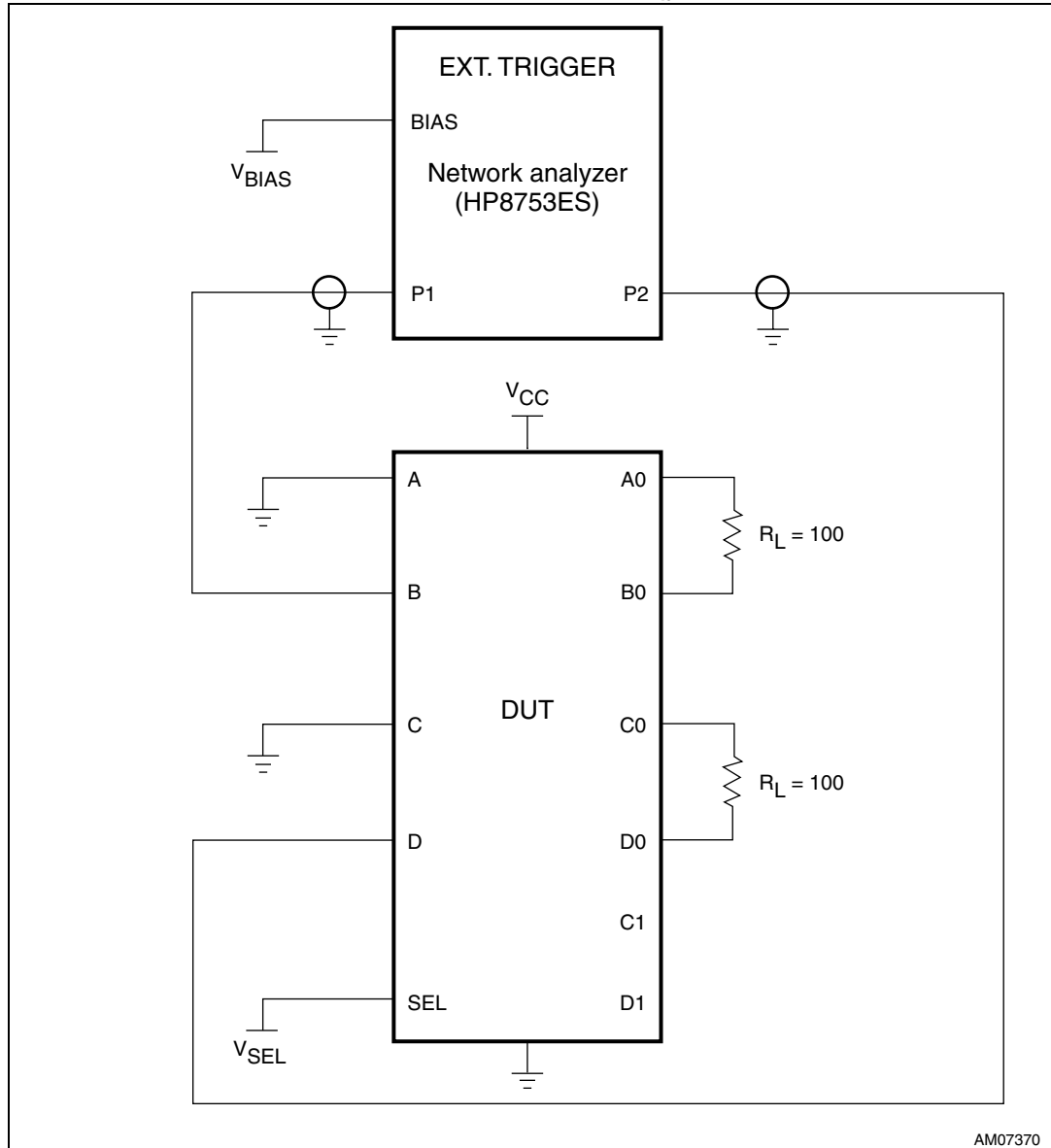

1. C_L includes probe and jig capacitance.
2. A $50\ \Omega$ termination resistor is needed to match the loading of the network analyzer.

Crosstalk is measured at the output of the non-adjacent ON channel. For example, when $V_{SEL} = 0$, and B is the input, the output is measured at D. All unused analog input ports are connected to GND and output ports are left open.

HP8753ES setup:

- Average = 4
- $R_{BW} = 3\ \text{kHz}$
- $V_{BIAS} = 0.35\ \text{V}$
- ST = 2 s
- P1 = 0 dBm

STMUX1800E

Electrical characteristics

Figure 10. Test circuit for off isolation measurement (O_{IRR})

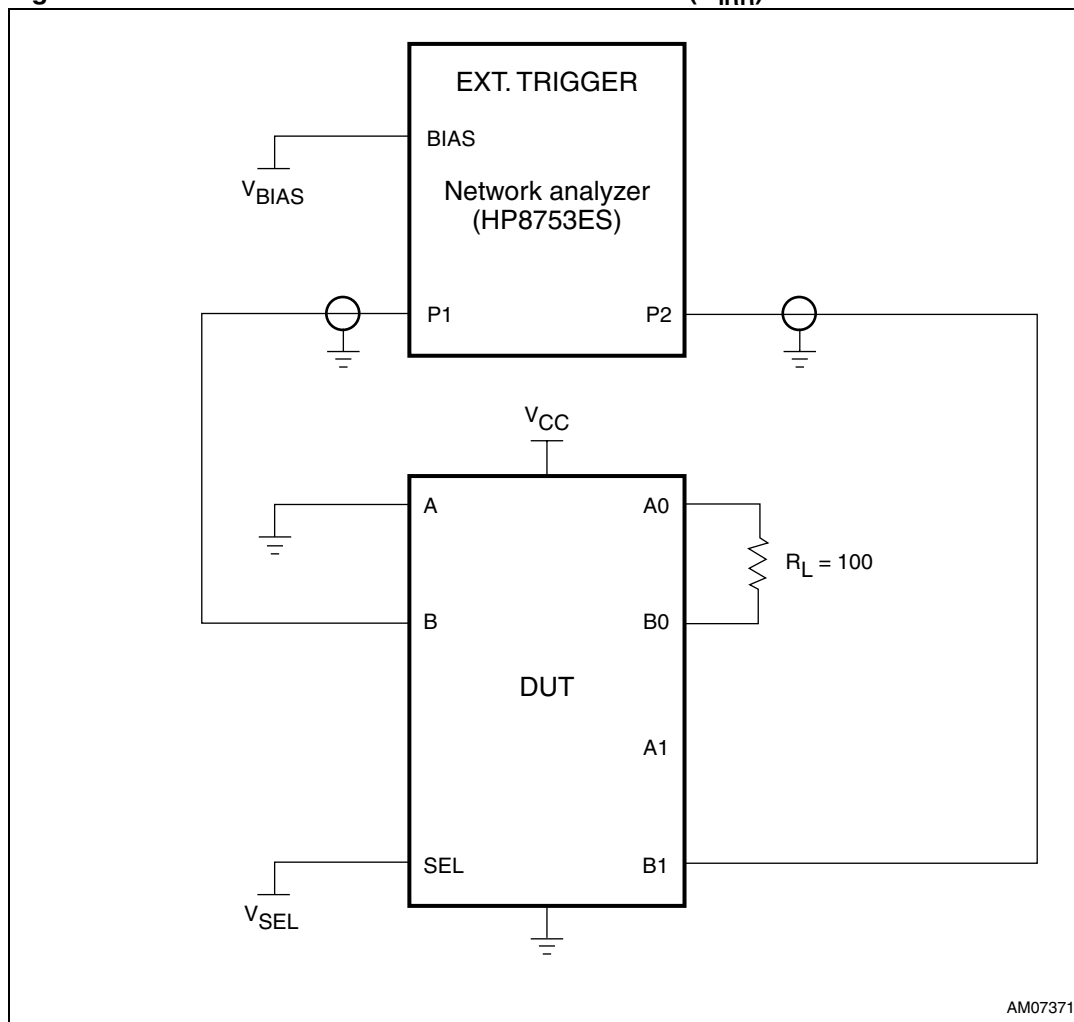

1. C_L includes probe and jig capacitance.
2. A $50\ \Omega$ termination resistor is needed to match the loading of the network analyzer.

Off isolation is measured at the output of the OFF channel. For example, when $V_{SEL} = 0$, and B is the input, the output is measured at B1. All unused analog input ports are connected to GND and output ports are left open.

HP8753ES setup:

- Average = 4
- $R_{BW} = 3\ \text{kHz}$
- $V_{BIAS} = 0.35\ \text{V}$
- ST = 2 s
- P1 = 0 dBm

4 Package mechanical data

ECOPACK®

In order to meet environmental requirements, ST offers these devices in different grades of ECOPACK® packages, depending on their level of environmental compliance. ECOPACK® specifications, grade definitions and product status are available at: www.st.com. ECOPACK® is an ST trademark.

Figure 11. Package outline for QFN42 (3.5 x 9 x 0.75) - pitch 0.5 mm

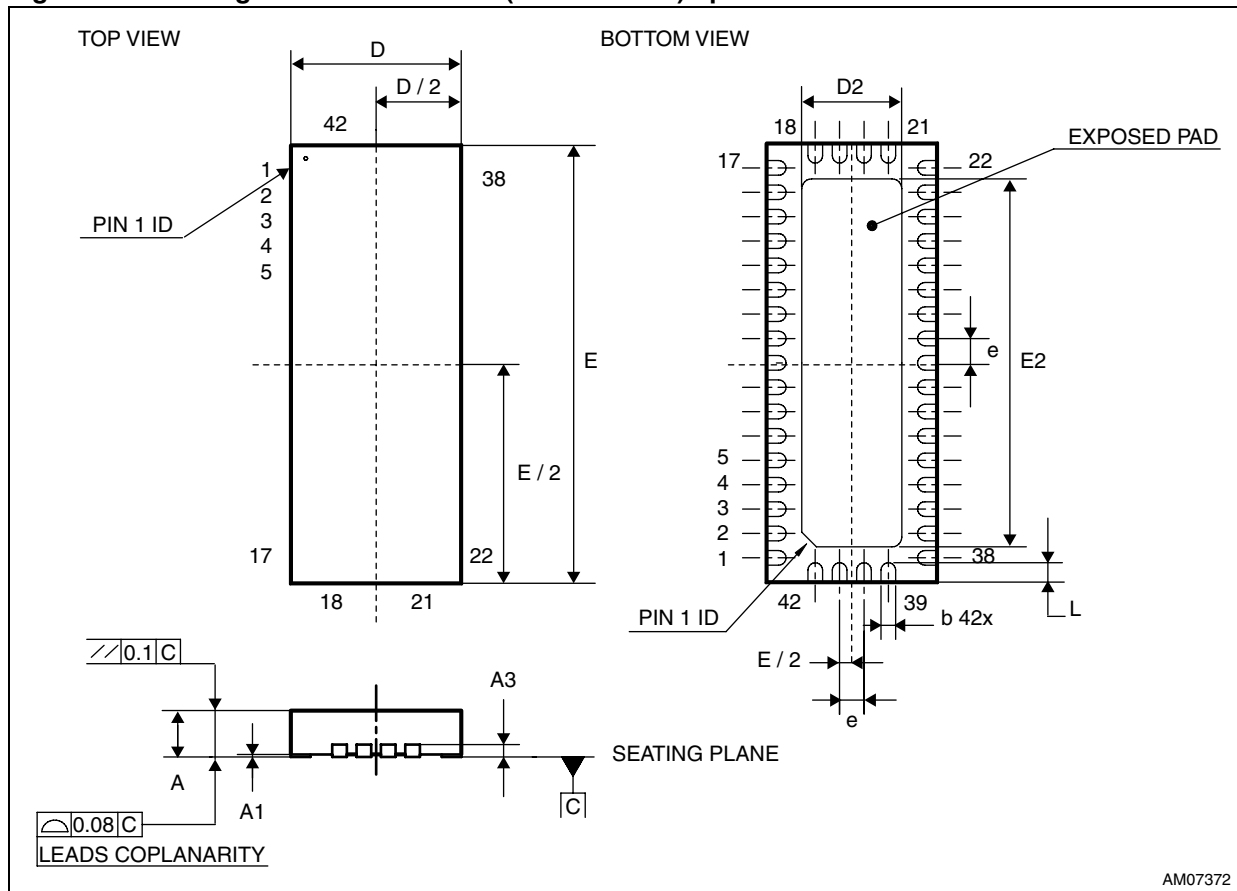

STMUX1800E

Package mechanical data

Table 14. Mechanical data for QFN42 (3.5 x 9 x 0.75) - pitch 0.5 mm

Symbol	millimeters		
	Min.	Typ.	Max.
A	0.70	0.75	0.80
A1	0	0.02	0.05
A3	—	0.20	—
b	0.20	0.25	0.30
D	3.40	3.50	3.60
D2	2	2.05	2.10
E	8.90	9	9.10
E2	7.50	7.55	7.60
e	—	0.50	—
L	0.30	0.40	0.50

Package mechanical data

STMUX1800E

Figure 12. Footprint recommendation for QFN42 (3.5 x 9 x 0.75) - pitch 0.5 mm

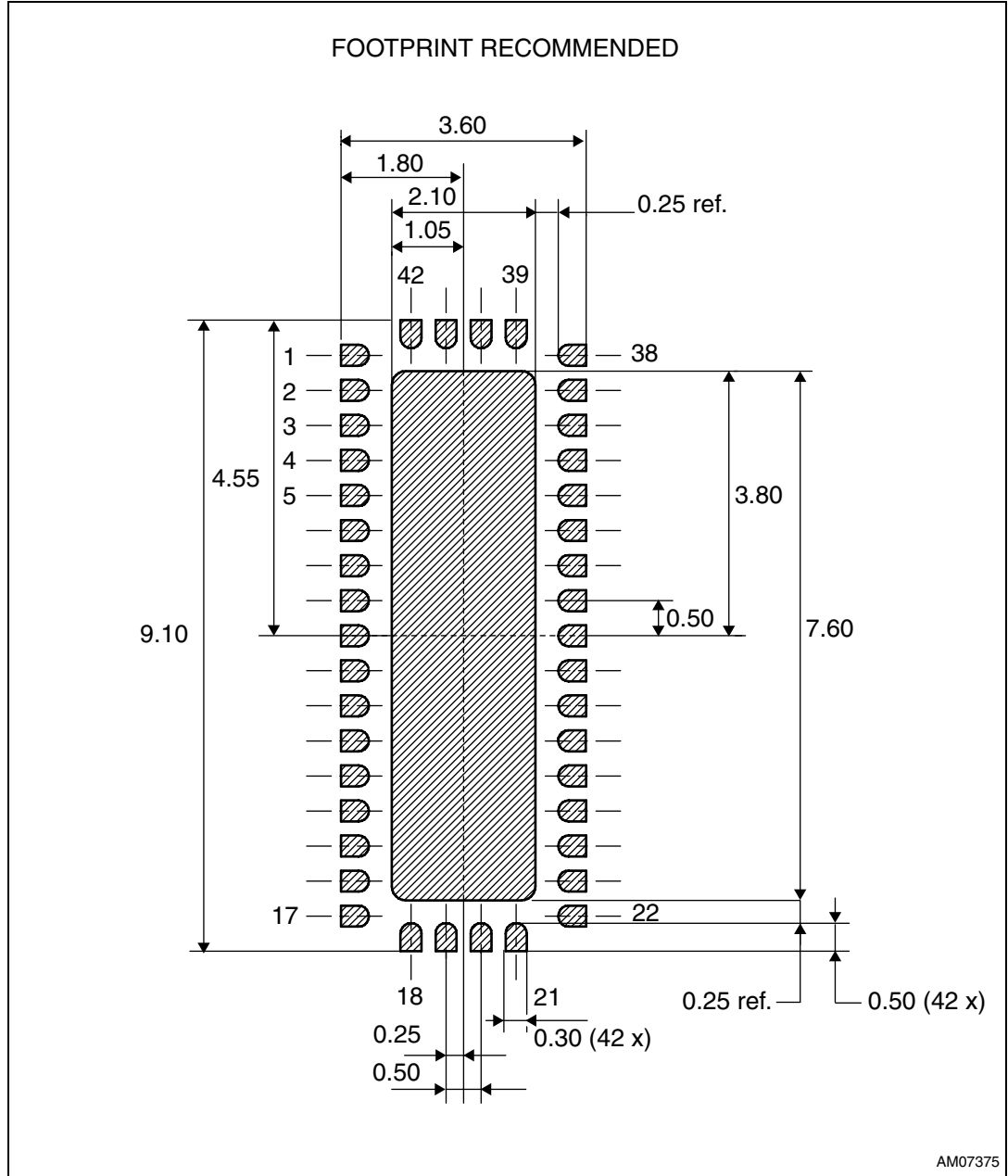

STMUX1800E

Package mechanical data

Figure 13. Carrier tape information for QFN42 (3.5 x 9 x 0.75) - pitch 0.5 mm

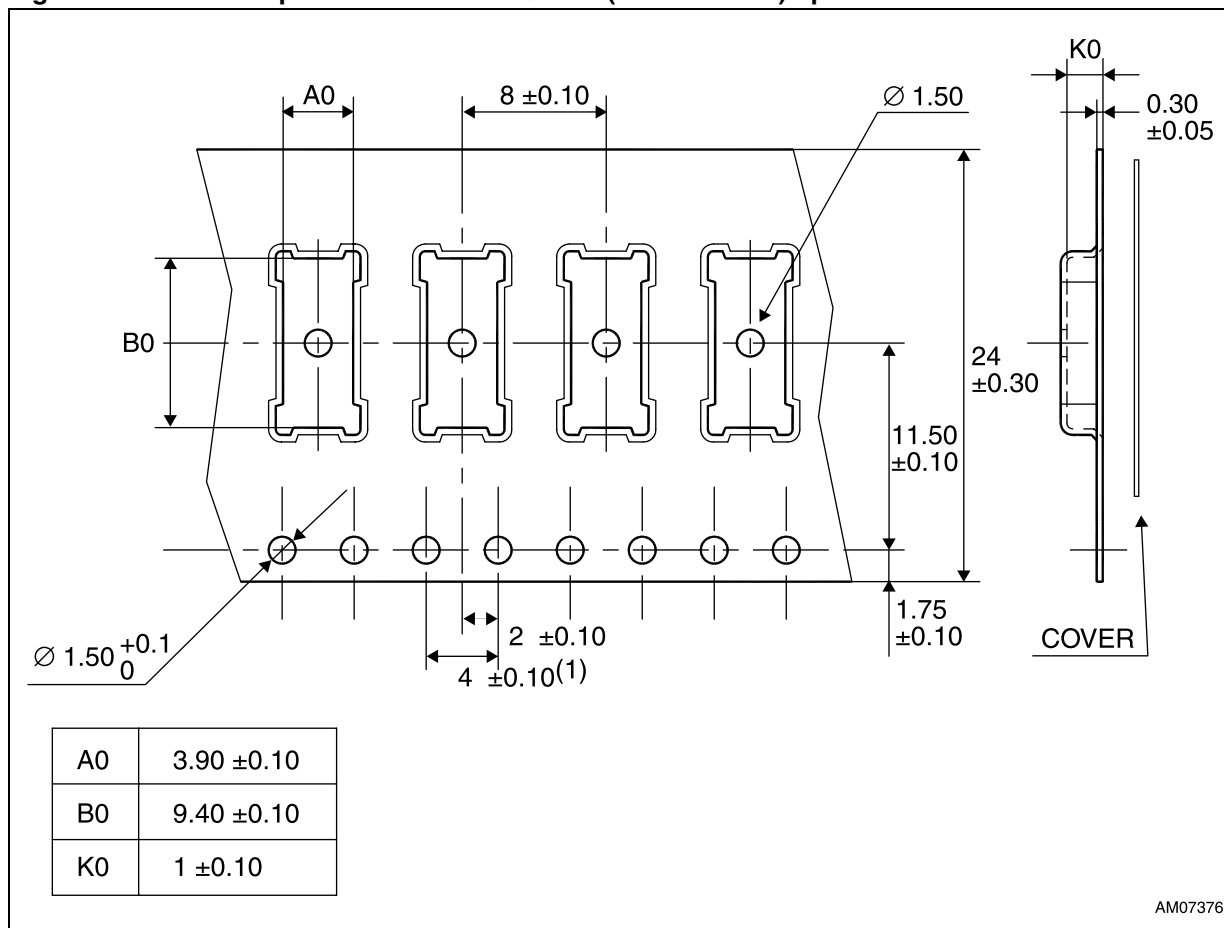

1. 10 sprocket hole pitch cumulative tolerance ±0.20.

Package mechanical data

STMUX1800E

Figure 14. Reel information for QFN42 (3.5 x 9 x 0.75) - pitch 0.5 mm

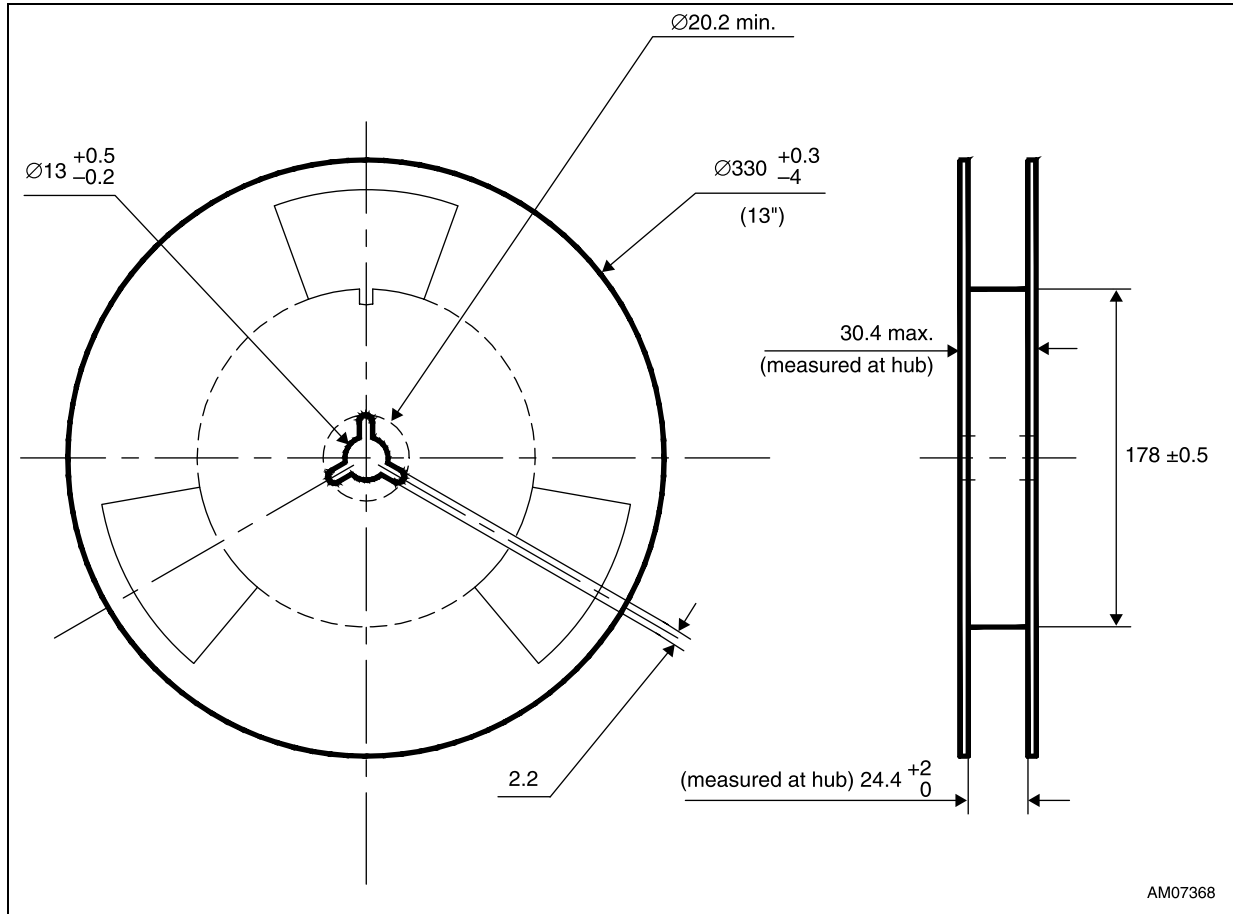

5 Revision history

Table 15. Document revision history

Date	Revision	Changes
09-Dec-2009	1	Initial release.
11-Oct-2010	2	Document reformatted, updated <i>Features</i> and “max. low power mode” in <i>Table 10.</i> , replaced V_{DD} by V_{CC} , corrected typo in <i>Figure 1</i> , <i>Figure 3</i> to <i>Figure 7</i> .
09-Nov-2011	3	Corrected order code in <i>Table 1</i> , updated <i>Section 2</i> and Disclaimer, minor text corrections throughout document.

STMUX1800E

Please Read Carefully:

Information in this document is provided solely in connection with ST products. STMicroelectronics NV and its subsidiaries ("ST") reserve the right to make changes, corrections, modifications or improvements, to this document, and the products and services described herein at any time, without notice.

All ST products are sold pursuant to ST's terms and conditions of sale.

Purchasers are solely responsible for the choice, selection and use of the ST products and services described herein, and ST assumes no liability whatsoever relating to the choice, selection or use of the ST products and services described herein.

No license, express or implied, by estoppel or otherwise, to any intellectual property rights is granted under this document. If any part of this document refers to any third party products or services it shall not be deemed a license grant by ST for the use of such third party products or services, or any intellectual property contained therein or considered as a warranty covering the use in any manner whatsoever of such third party products or services or any intellectual property contained therein.

UNLESS OTHERWISE SET FORTH IN ST'S TERMS AND CONDITIONS OF SALE ST DISCLAIMS ANY EXPRESS OR IMPLIED WARRANTY WITH RESPECT TO THE USE AND/OR SALE OF ST PRODUCTS INCLUDING WITHOUT LIMITATION IMPLIED WARRANTIES OF MERCHANTABILITY, FITNESS FOR A PARTICULAR PURPOSE (AND THEIR EQUIVALENTS UNDER THE LAWS OF ANY JURISDICTION), OR INFRINGEMENT OF ANY PATENT, COPYRIGHT OR OTHER INTELLECTUAL PROPERTY RIGHT.

UNLESS EXPRESSLY APPROVED IN WRITING BY TWO AUTHORIZED ST REPRESENTATIVES, ST PRODUCTS ARE NOT RECOMMENDED, AUTHORIZED OR WARRANTED FOR USE IN MILITARY, AIR CRAFT, SPACE, LIFE SAVING, OR LIFE SUSTAINING APPLICATIONS, NOR IN PRODUCTS OR SYSTEMS WHERE FAILURE OR MALFUNCTION MAY RESULT IN PERSONAL INJURY, DEATH, OR SEVERE PROPERTY OR ENVIRONMENTAL DAMAGE. ST PRODUCTS WHICH ARE NOT SPECIFIED AS "AUTOMOTIVE GRADE" MAY ONLY BE USED IN AUTOMOTIVE APPLICATIONS AT USER'S OWN RISK.

Resale of ST products with provisions different from the statements and/or technical features set forth in this document shall immediately void any warranty granted by ST for the ST product or service described herein and shall not create or extend in any manner whatsoever, any liability of ST.

ST and the ST logo are trademarks or registered trademarks of ST in various countries.

Information in this document supersedes and replaces all information previously supplied.

The ST logo is a registered trademark of STMicroelectronics. All other names are the property of their respective owners.

© 2011 STMicroelectronics - All rights reserved

STMicroelectronics group of companies

Australia - Belgium - Brazil - Canada - China - Czech Republic - Finland - France - Germany - Hong Kong - India - Israel - Italy - Japan - Malaysia - Malta - Morocco - Philippines - Singapore - Spain - Sweden - Switzerland - United Kingdom - United States of America

www.st.com