

## Excellent Integrated System Limited

Stocking Distributor

Click to view price, real time Inventory, Delivery & Lifecycle Information:

[Judco Manufacturing, Inc.](#)  
[40-1672-02](#)

For any questions, you can email us directly:

[sales@integrated-circuit.com](mailto:sales@integrated-circuit.com)

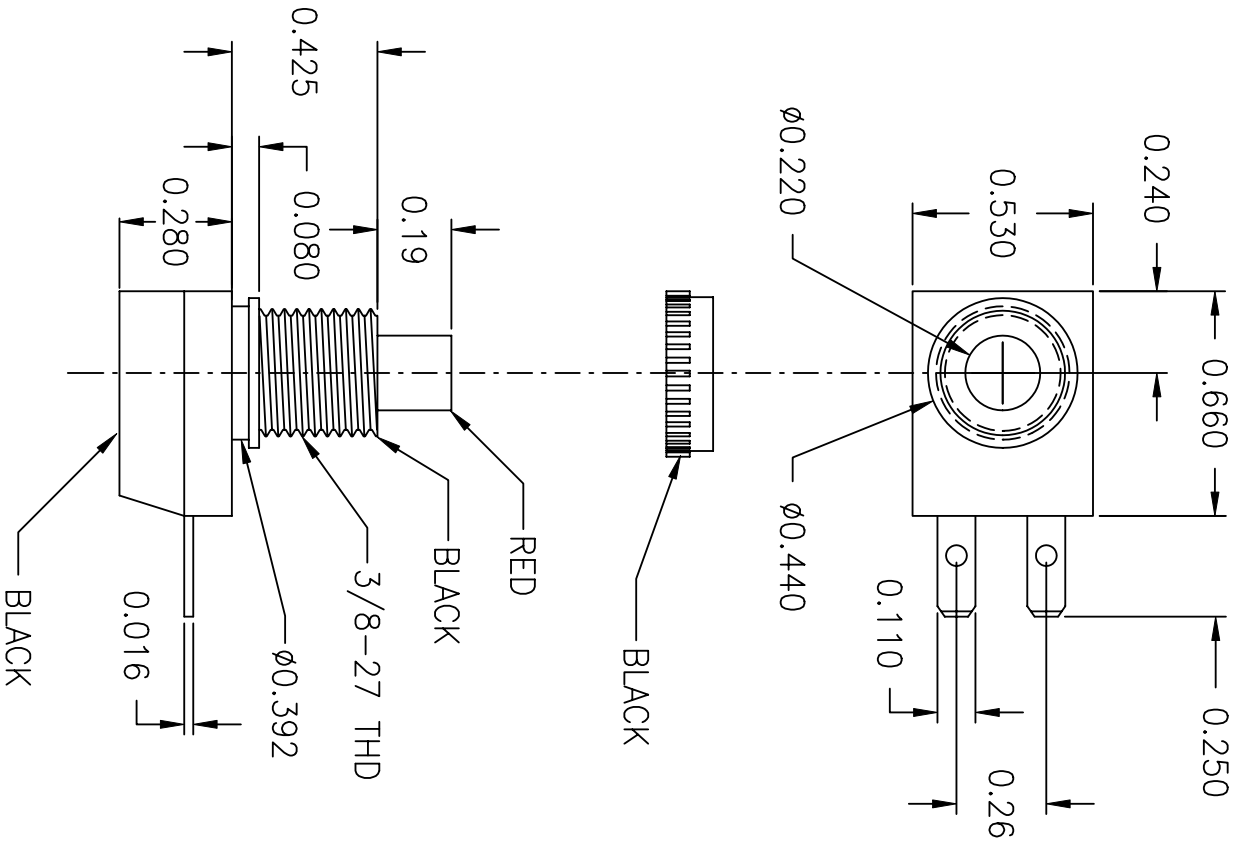

LTR	EN	DESCRIPTION	APPR	BY	DATE
A	-	INITIAL RELEASE	RB	EM	2-03-04

JUDCO INVENTORY NO. 40-1672-02  
 SWITCH TYPE: PUSH ON-PUSH OFF, SPDT  
 NUTS PACKED SEPARATELY

CUSTOMER: DIGI KEY  
 CUST. PN: 501 PB-ND  
 APPROVED BY: \_\_\_\_\_  
 DATE: \_\_\_\_\_

DIMENSIONS IN INCHES  
 DIMENSIONS ARE REFERENCE

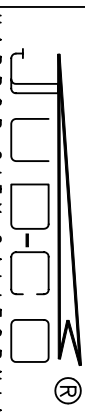

TITLE  
 HARBOR CITY CALIFORNIA  
 OUTLINE  
 J-188A-1

DRAWN: EM 02-03-04  
 APPR: KJ 02-03-04  
 DWG. NO. 1415-559

1415US59A.DWG

SHEET 1 OF 1

This document embodies a product, component, and/or design proprietary to JUDCO MANUFACTURING INC., and which is protected either as a trade secret, by U.S. Patent, or by copyright. It may not be used in any way without written express consent of JUDCO MANUFACTURING INC.