

Excellent Integrated System Limited

Stocking Distributor

Click to view price, real time Inventory, Delivery & Lifecycle Information:

[Molex Connector Corporation](#)
[0638132400](#)

For any questions, you can email us directly:

sales@integrated-circuit.com

Extractor Tool for 0.6mm (.02") CP Crimp Terminals

Extractor Tool		
	Application Tooling Specification Sheet	

FEATURES

- This Extractor Tool is for the removal of 98913 and 64322 Series female terminals from CMC connector.

SCOPE

Products: 0.6mm (.02") CP Crimp Terminal for CMC connector.

Terminal Series No.	Description	Housing Series No.	Terminal Order No.					
64322	0.635mm (.025") CP Female Terminal	98835, 98993, 98994, and 98995	64322-1019	64322-1029	64322-1039	64322-1219	64322-1229	
			64322-1239	64322-1319	64322-1329	64322-1339	64322-1349	
			64322-1359					
98913	0.635mm (.025") CP Female Terminal	98835, 98993, 98994, and 98995	98913-1019	98913-1029	98913-1039	98913-1219	98913-1229	
			98913-1239	98913-1319	98913-1329	98913-1339	98913-1349	
			98913-1359	98913-1419	98913-3019	98913-3029	98913-3039	

OPERATION:

When removing a damaged crimped wire from the CMC connector follow the steps below:

1. The secondary lock on the CMC connector will need to be opened first. See Figure 1.
2. Using a screwdriver insert the flat edge under the tab of the secondary lock and pull up. Use your fingers to open the lock completely.

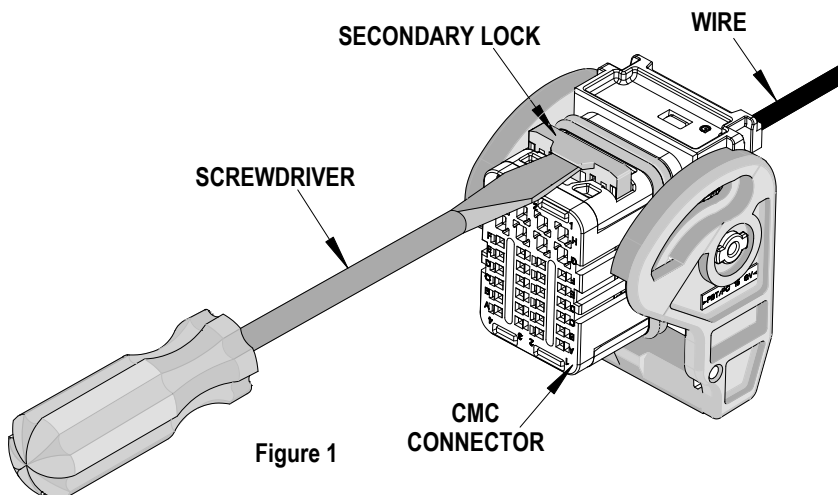

Extractor Tool for 0.6mm (.02") CP Crimp Terminals

- Position the blades of the extraction tool into the two small cavities of the slot in the front face of the housing as shown in Figure 2. Use the identifying markings on both the front and back of the connector to locate the opening used to extract the crimped wire.

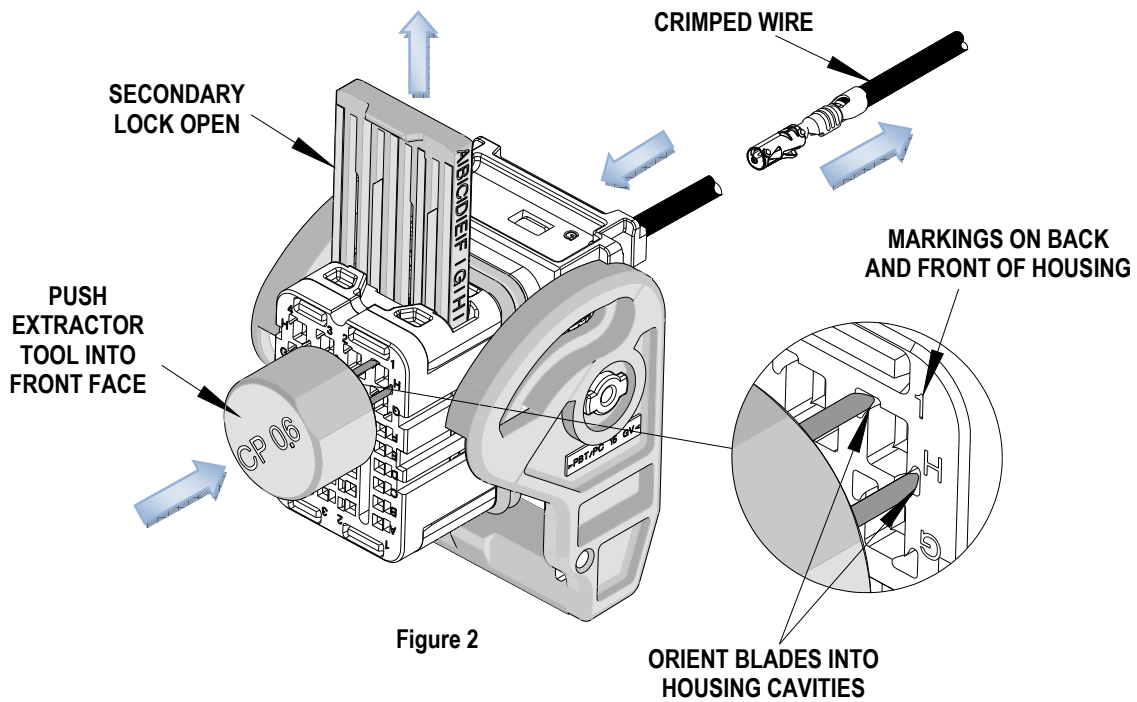

Figure 2

- Push extractor tool into the desired slot until it clicks or comes to a stop. Do not force the extractor tool any further or there can be damage to the housing.
- Gently push the wire forward towards the housing and then pull out of the CMC housing.
- Molex does not offer repair parts for Extractor Tools due to the inexpensive nature of these tools.

Visit our Web site at <http://www.molex.com>