

Excellent Integrated System Limited



Stocking Distributor

Click to view price, real time Inventory, Delivery & Lifecycle Information:

[Rohm Semiconductor](#)
[RCX510N25](#)

For any questions, you can email us directly:

sales@integrated-circuit.com

ROHM		PRODUCTS TO-220FM	TYPE RCX510N25	PAGE 1/4
1. TYPE	RCX510N25			
2. STRUCTURE	SILICON N-CHANNEL MOS FET			
3. APPLICATIONS	SWITCHING			
4. ABSOLUTE MAXIMUM RATINGS	[Ta=25°C]			
DRAIN-SOURCE VOLTAGE		V _{DSS}	• • •	250V
GATE-SOURCE VOLTAGE		V _{GSS}	• • •	±30V
DRAIN CURRENT	CONTINUOUS	I _D	• • •	±51A*
	PULSED	I _{DP}	• • •	±204A* PW ≤ 10 μs DUTY CYCLE ≤ 1%
SOURCE CURRENT	CONTINUOUS	I _S	• • •	51A*
(BODY DIODE)	PULSED	I _{SP}	• • •	204A* PW ≤ 10 μs DUTY CYCLE ≤ 1%
TOTAL POWER DISSIPATION		P _D	• • •	40W (Tc=25°C)
CHANNEL TEMPERATURE		T _{ch}	• • •	150°C
RANGE OF STORAGE TEMPERATURE		T _{stg}	• • •	-55~150°C
5. THERMAL RESISTANCE				
CHANNEL TO CASE		R _{th(ch-c)}	• • •	3.13°C/W
* Limited only by maximum channel temperature allowed				
DESIGN	CHECK	APPROVAL	DATE : 26/DEC/2008	SPECIFICATION No.TSQ03050-RCX510N25
			REV. : 0	ROHM CO., LTD.

6.ELECTRICAL CHARACTERISTICS [Ta=25°C]

《MOSFET.》

PARAMETER	ITEM	CONDITION	MIN.	TYP.	MAX.
GATE-SOURCE LEAKAGE	I_{GSS}	$V_{GS} \pm 30V / V_{DS} = 0V$	—	—	$\pm 100nA$
DRAIN-SOURCE BREAKDOWN VOLTAGE	$V_{(BR)DSS}$	$I_D = 1mA / V_{GS} = 0V$	250V	—	—
ZERO GATE VOLTAGE DRAIN CURRENT	I_{DSS}	$V_{DS} = 250V / V_{GS} = 0V$	—	—	10 μA
GATE THRESHOLD VOLTAGE	$V_{GS(th)}$	$V_{DS} = 10V / I_D = 1mA$	3.0V	—	5.0V
STATIC DRAIN-SOURCE ON-STATE RESISTANCE	$R_{DS(on)}$ * PULSED	$I_D = 25.5A / V_{GS} = 10V$	—	48m Ω	65m Ω
FORWARD TRANSFER ADMITTANCE	$ Y_{fs} $ * PULSED	$V_{DS} = 10V / I_D = 25.5A$	15S	—	—
INPUT CAPACITANCE	C_{iss}	$V_{DS} = 25V$ $V_{GS} = 0V$ $f = 1MHz$	—	7000pF	—
OUTPUT CAPACITANCE	C_{oss}		—	350pF	—
REVERSE TRANSFER CAPACITANCE	C_{rss}		—	200pF	—
TURN-ON DELAY TIME	$t_{d(on)}$ * PULSED	$V_{DD} \doteq 125V$ $I_D = 25.5A$ $V_{GS} = 10V$ $R_L = 4.9\Omega$ $R_G = 10\Omega$ see Fig. 1-1,1-2	—	65ns	—
RISE TIME	t_r * PULSED		—	300ns	—
TURN-OFF DELAY TIME	$t_{d(off)}$ * PULSED		—	170ns	—
FALL TIME	t_f * PULSED		—	210ns	—
TOTAL GATE CHARGE	Q_g * PULSED	$V_{DD} \doteq 125V$ $I_D = 51A$ $V_{GS} = 10V$ $R_L = 2.5\Omega / R_G = 10\Omega$ See Fig.2-1,2-2	—	120nC	—
GATE-SOURCE CHARGE	Q_{gs} * PULSED		—	40nC	—
GATE-DRAIN CHARGE	Q_{gd} * PULSED		—	40nC	—

BODY DIODE (SOURCE-DRAIN)

PARAMETER	ITEM	CONDITION	MIN.	TYP.	MAX.
FORWARD VOLTAGE	V_{SD} * PULSED	$I_S = 51A / V_{GS} = 0V$	—	—	1.5V



PRODUCTS
TO-220FM

TYPE
RCX510N25

PAGE
3/4

7. INNER CIRCUIT

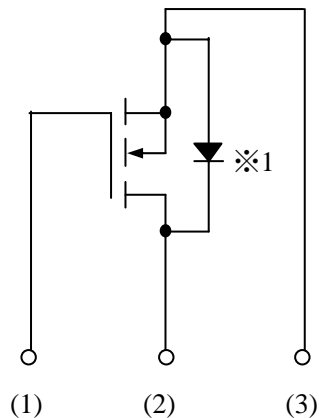

※ 1 BODY DIODE

- (1) GATE
- (2) DRAIN
- (3) SOURCE

8. MARKING

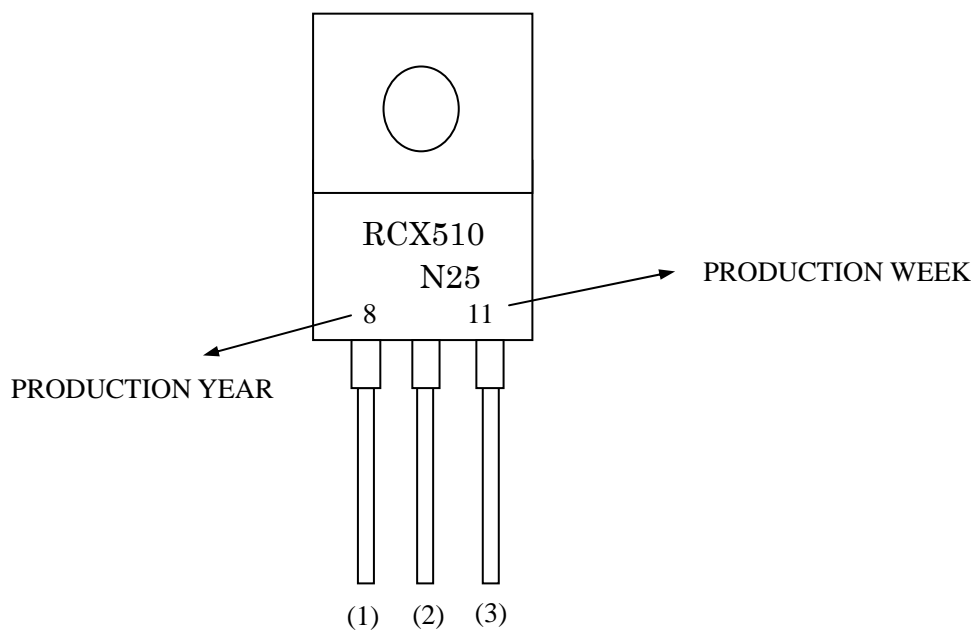

9. MEASUREMENT CIRCUIT

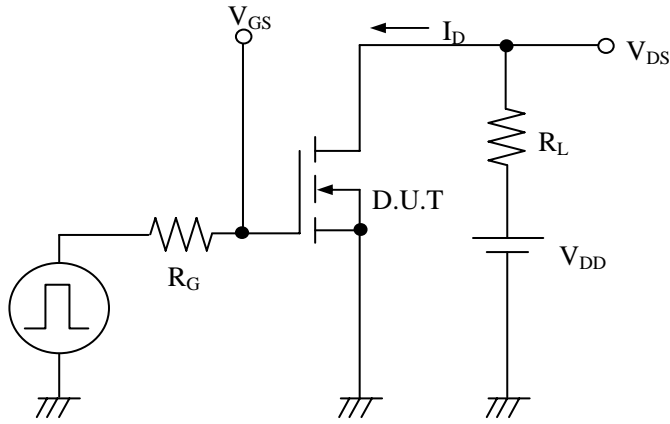

Fig.1-1 SWITCHING TIME MEASUREMENT CIRCUIT

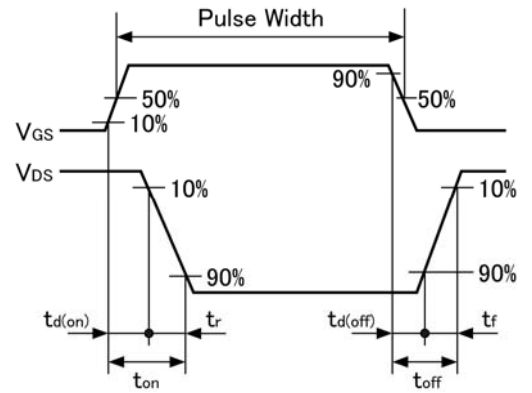

Fig.1-2 SWITCHING WAVEFORMS

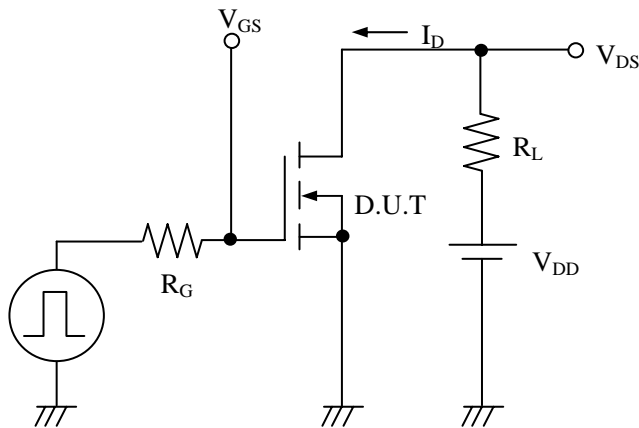

Fig.2-1 GATE CHARGE MEASUREMENT CIRCUIT

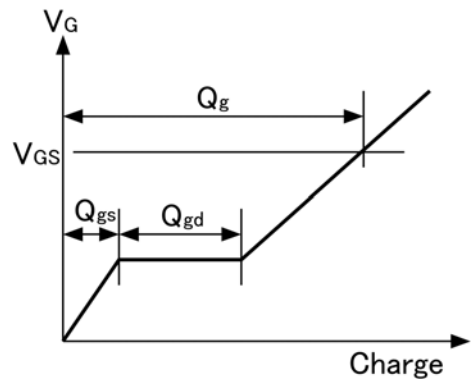

Fig.2-2 GATE CHARGE WAVEFORM