



Distributor of Molex Connector Corporation: Excellent Integrated System Limited
Datasheet of 0191640051 - Connector Quick Connect Receptacle 14-16 AWG 0.250"
(6.35mm) Crimp

Contact us: sales@integrated-circuit.com Website: www.integrated-circuit.com

Excellent Integrated System Limited

Stocking Distributor

Click to view price, real time Inventory, Delivery & Lifecycle Information:

[Molex Connector Corporation](#)
[0191640051](#)

For any questions, you can email us directly:
sales@integrated-circuit.com

10	9	8	7	6	5	4	3	2	19164		
MATERIAL NUMBER	ENGINEERING NUMBER	TAPE MATERIAL NUMBER	TAPE ENGINEERING NUMBER	WIRE SIZE AWG	WIRE SIZE MM SQ.	FITS MALE TAB	PERMA-SEAL COLOR	Ⓒ1 A MAX.	Ⓒ1 D MWID	E Ⓒ1 MIN	H NOMINAL
191640017	SAA-9261	191640018	SAA-9261T	22-18	.25-1.5	.250 X .032	RED	1.50/38.1	.17/4.3	.081/2.05	.55/14.0
191640050	SBB-9263	191640051	SBB-9263T	16-14	1.0-2.5	.250 X .032	BLUE	1.50/38.1	.18/4.5	.081/2.05	.55/14.0
191640076	SC-9281	191640305	SC-9281T	12-10	4.0-6.0	.250 X .032	YELLOW	1.52/38.6	.23/5.8	.140/3.56	.56/14.2

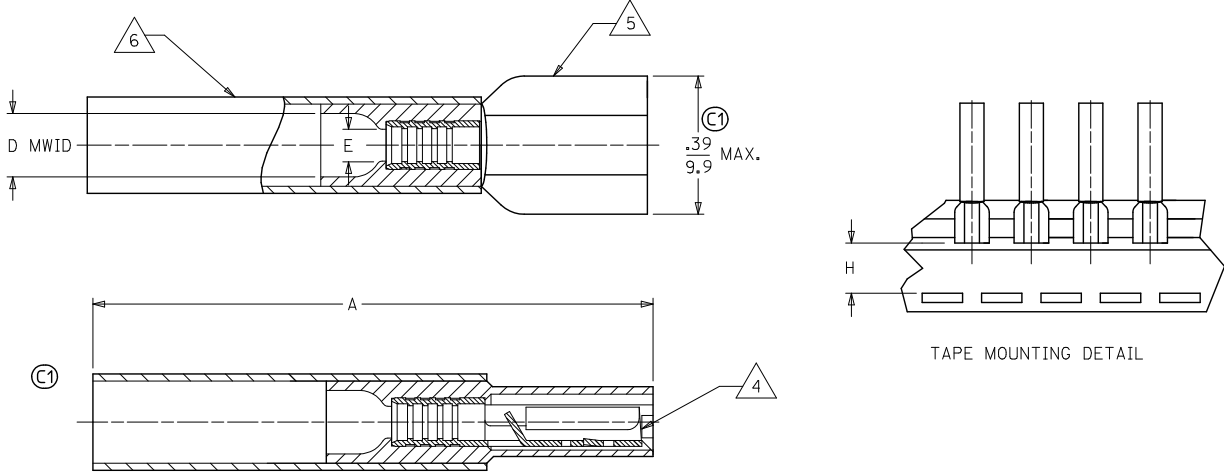

- NOTES:
- Ⓒ1 1. FEMALE RECEPTACLE CONFORMS TO UL310.
 - 2. ALL DIMENSIONS SHOWN ARE BEFORE SHRINK TUBING IS HEATED.
 - 3. *MWID* DENOTES MAX. WIRE INSULATION DIA.
 - 4. TAB MATERIAL: .018 THK, BRASS, PLATING, TIN.
 - 5. INSULATION MAT'L: MOLDED NYLON
 - 6. NYLON TUBING WITH HOTMELT INNER LINER. SEE CHART FOR COLOR.
 - 7. ALL PARTS ARE ROHS COMPLIANT.

CORRECT SPECS EC NO: WNA2010-0115 DRAWN BY: B.RODRAHL 2010/02/16 CHKD: MACNEIL 2010/02/18 APPR: MACNEIL 2010/02/22 REV: C1	QUALITY SYMBOLS	GENERAL TOLERANCES (UNLESS SPECIFIED) <table border="1"> <thead> <tr> <th></th> <th>mm</th> <th>INCH</th> </tr> </thead> <tbody> <tr> <td>4 PLACES</td> <td>± .15</td> <td>± .005</td> </tr> <tr> <td>3 PLACES</td> <td>± .25</td> <td>± .010</td> </tr> <tr> <td>2 PLACES</td> <td>± .38</td> <td>± .015</td> </tr> <tr> <td>1 PLACE</td> <td>± .51</td> <td>± .020</td> </tr> <tr> <td colspan="3">ANGULAR ± .5°</td> </tr> </tbody> </table>		mm	INCH	4 PLACES	± .15	± .005	3 PLACES	± .25	± .010	2 PLACES	± .38	± .015	1 PLACE	± .51	± .020	ANGULAR ± .5°			DIMENSION STYLE	SCALE	DESIGN UNITS	THIRD ANGLE PROJECTION
			mm	INCH																				
	4 PLACES		± .15	± .005																				
	3 PLACES		± .25	± .010																				
2 PLACES	± .38	± .015																						
1 PLACE	± .51	± .020																						
ANGULAR ± .5°																								
	IN/MM	---	INCH																					
	DRAWN BY: BRE	DATE: 2002/10/29	TITLE: PERMA-SEAL COUPLER FEMALE RECEPTACLE	MOLEX INCORPORATED DOCUMENT NO. SD-19164-020 SHEET NO. 1 OF 1																				
	CHECKED BY: HEB	DATE: 2002/10/29																						
	APPROVED BY: RWD	DATE: 2002/10/29		MATERIAL NO. SEE CHART SIZE B THIS DRAWING CONTAINS INFORMATION THAT IS PROPRIETARY TO MOLEX INCORPORATED AND SHOULD NOT BE USED WITHOUT WRITTEN PERMISSION																				