



Excellent Integrated System Limited

Stocking Distributor

Click to view price, real time Inventory, Delivery & Lifecycle Information:

[Essentra Components \(formerly Richco, Inc.\)](#)
[WIT-30RAR1-2](#)

For any questions, you can email us directly:
sales@integrated-circuit.com

PART NO.	LENGTH "L" APROX.	BUNDLE DIA.
WIT-30RAR1-2	4.75 (120.7)	1.00 (25.4)
WIT-30LAR1-2	5.75 (146.0)	1.25 (31.8)

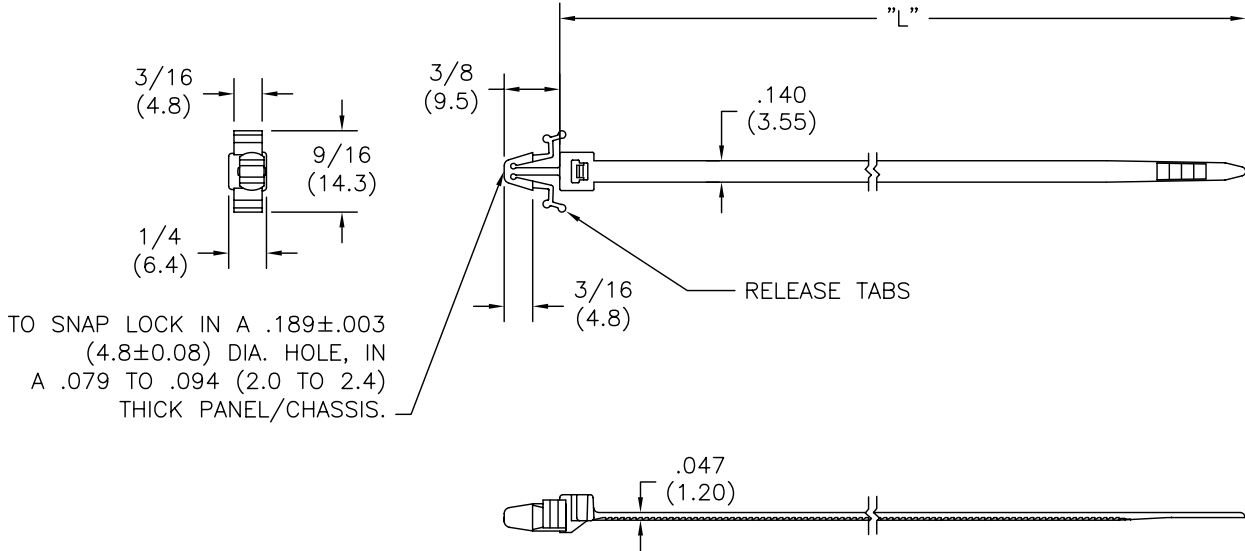

NOTES:

1. MATERIAL: NYLON 6/6 (RMS-01).
2. COLOR: NATURAL.
3. MIN. LOOP TENSILE 30 LBS.

TITLE: WIT-30XAR1-2		DWG IN IN (MM) FINAL		PRINT TYPE CA	
TOLERANCES UNLESS NOTED .XX= $\pm .010$.XXX= $\pm .005$ FRAC= $\pm 1/32$ ANG= $\pm 1^\circ$	FILE # WIT-30XAR1-2	DWN: DLC	APP:	PART # WIT-30XAR1-2	
	MAT'L: SEE NOTES	DT: 5/24/01	DT:		
	RE: RICHCO, INC.	RICHCO INC. PO BOX 804238, CHICAGO, 60680 (773) 539-4060			

B	SEE ECN #893 FOR CHANGES	SM 12.15.04
A	RELEASED FOR PRODUCTION	SM 09.20.01
REV	DESCRIPTION	ENGR DATE