

Excellent Integrated System Limited

Stocking Distributor

Click to view price, real time Inventory, Delivery & Lifecycle Information:

[Advanced Linear Devices Inc.](#)
[ALD1116PAL](#)

For any questions, you can email us directly:

sales@integrated-circuit.com



ALD1106/ALD1116

QUAD/DUAL N-CHANNEL MATCHED PAIR MOSFET ARRAY

GENERAL DESCRIPTION

The ALD1106/ALD1116 are monolithic quad/dual N-channel enhancement mode matched MOSFET transistor arrays intended for a broad range of precision analog applications. The ALD1106/ALD1116 offer high input impedance and negative current temperature coefficient. The transistor pairs are matched for minimum offset voltage and differential thermal response, and they are designed for precision analog switching and amplifying applications in +2V to +12V systems where low input bias current, low input capacitance and fast switching speed are desired. These MOSFET devices feature very large (almost infinite) current gain in a low frequency, or near DC, operating environment. The ALD1106/ALD1116 are building blocks for differential amplifier input stages, transmission gates, and multiplexer applications, current sources and many precision analog circuits.

FEATURES

- Low threshold voltage of 0.7V
- Low input capacitance
- Low Vos 2mV typical
- High input impedance -- 10¹⁴Ω typical
- Negative current (IDS) temperature coefficient
- Enhancement-mode (normally off)
- DC current gain 10⁹
- Low input and output leakage currents
- RoHS compliant

ORDERING INFORMATION ("L" suffix denotes lead-free (RoHS))

Operating Temperature Range*		
0°C to +70°C	0°C to +70°C	-55°C to +125°C
8-Pin SOIC Package	8-Pin Plastic Dip Package	8-Pin Cerdip Package
ALD1116SAL	ALD1116PAL	ALD1116DA
14-Pin SOIC Package	14-Pin Plastic Dip Package	14-Pin Cerdip Package
ALD1106SBL	ALD1106PBL	ALD1106DB

* Contact factory for leaded (non-RoHS) or high temperature versions.

BLOCK DIAGRAM

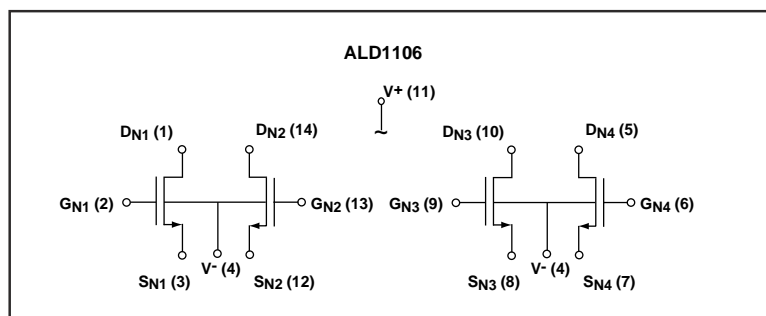

APPLICATIONS

- Precision current mirrors
- Precision current sources
- Voltage choppers
- Differential amplifier input stage
- Voltage comparator
- Data converters
- Sample and Hold
- Analog signal processing

PIN CONFIGURATION

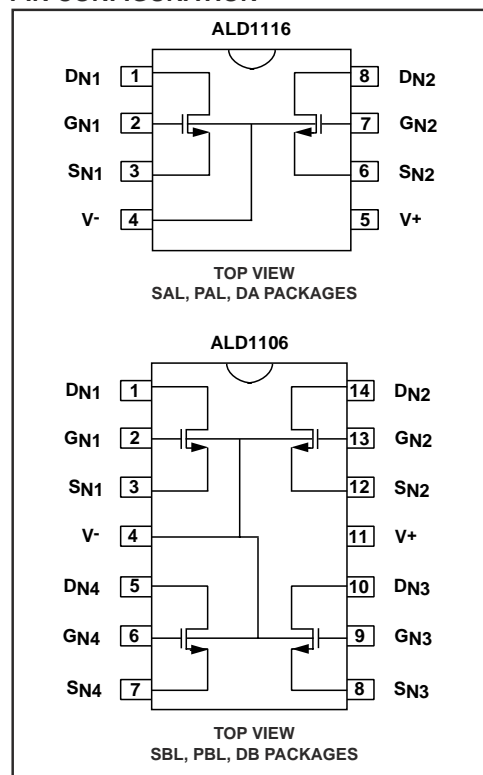

BLOCK DIAGRAM

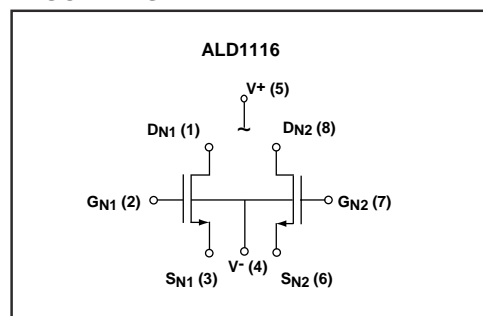

ABSOLUTE MAXIMUM RATINGS

Drain-source voltage, V_{DS} _____ 10.6V
 Gate-source voltage, V_{GS} _____ 10.6V
 Power dissipation _____ 500mW
 Operating temperature range SAL, PAL, SBL, PBL packages _____ 0°C to +70°C
 DA, DB packages _____ -55°C to +125°C
 Storage temperature range _____ -65°C to +150°C
 Lead temperature, 10 seconds _____ +260°C
 CAUTION: ESD Sensitive Device. Use static control procedures in ESD controlled environment.

OPERATING ELECTRICAL CHARACTERISTICS

$T_A = 25^\circ\text{C}$ unless otherwise specified

Parameter	Symbol	ALD1106			ALD1116			Unit	Test Conditions
		Min	Typ	Max	Min	Typ	Max		
Gate Threshold Voltage	V_T	0.4	0.7	1.0	0.4	0.7	1.0	V	$I_{DS} = 1.0\mu\text{A}$ $V_{GS} = V_{DS}$
Offset Voltage $V_{GS1} - V_{GS2}$	V_{OS}		2	10		2	10	mV	$I_{DS} = 10\mu\text{A}$ $V_{GS} = V_{DS}$
Gate Threshold Temperature Drift ²	TC_{VT}		-1.2			-1.2		mV/°C	
On Drain Current	$I_{DS(ON)}$	3.0	4.8		3.0	4.8		mA	$V_{GS} = V_{DS} = 5V$
Transconductance	G_{IS}	1.0	1.8		1.0	1.8		mmho	$V_{DS} = 5V$ $I_{DS} = 10\text{mA}$
Mismatch	ΔG_{fs}		0.5			0.5		%	
Output Conductance	G_{OS}		200			200		μmho	$V_{DS} = 5V$ $I_{DS} = 10\text{mA}$
Drain Source On Resistance	$R_{DS(ON)}$		350	500		350	500	Ω	$V_{DS} = 0.1V$ $V_{GS} = 5V$
Drain Source On Resistance Mismatch	$\Delta_{DS(ON)}$		0.5			0.5		%	$V_{DS} = 0.1V$ $V_{GS} = 5V$
Drain Source Breakdown Voltage	BV_{DSS}	12			12			V	$I_{DS} = 1.0\mu\text{A}$ $V_{GS} = 0V$
Off Drain Current ¹	$I_{DS(OFF)}$		10	400		10	400	pA nA	$V_{DS} = 12V$ $V_{GS} = 0V$ $T_A = 125^\circ\text{C}$
Gate Leakage Current	I_{GSS}		0.1	10		0.1	10	pA nA	$V_{DS} = 0V$ $V_{GS} = 12V$ $T_A = 125^\circ\text{C}$
Input Capacitance ²	C_{ISS}		1	3		1	3	pF	

Notes: ¹ Consists of junction leakage currents
² Sample tested parameters

TYPICAL PERFORMANCE CHARACTERISTICS

OUTPUT CHARACTERISTICS

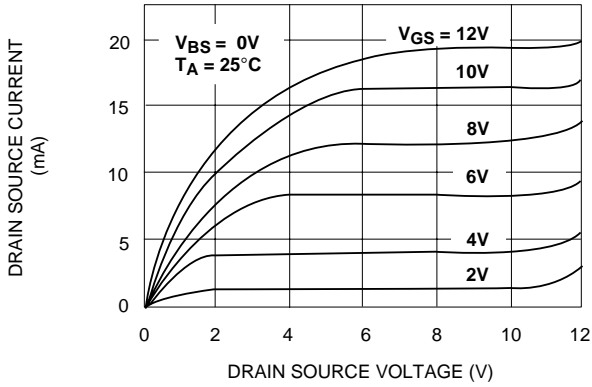

LOW VOLTAGE OUTPUT CHARACTERISTICS

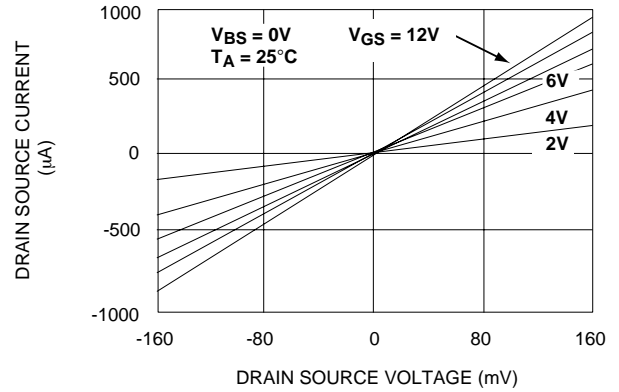

FORWARD TRANSCONDUCTANCE vs. DRAIN SOURCE VOLTAGE

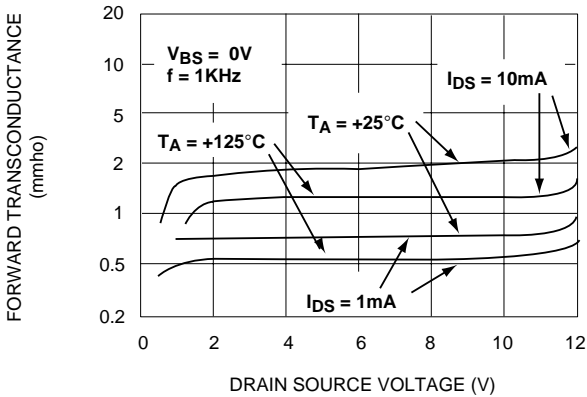

TRANSFER CHARACTERISTIC WITH SUBSTRATE BIAS

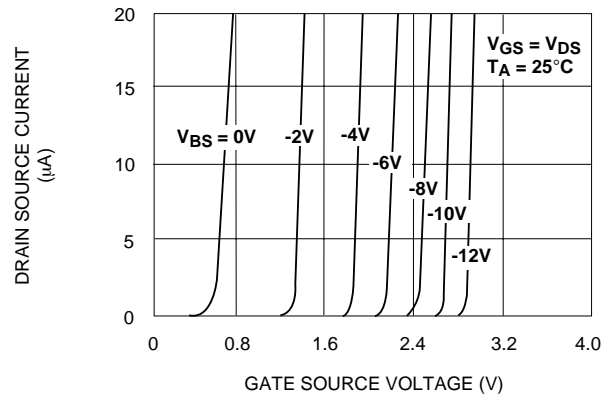

DRAIN SOURCE ON RESISTANCE $R_{DS(ON)}$ vs. GATE SOURCE VOLTAGE

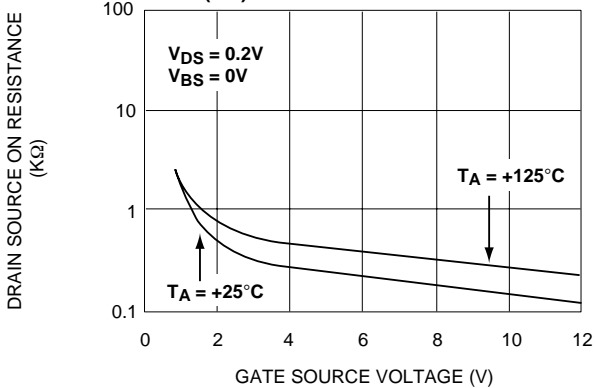

OFF DRAIN CURRENT vs. AMBIENT TEMPERATURE

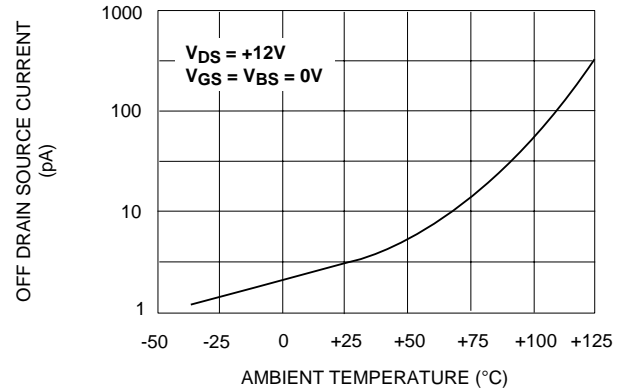

TYPICAL APPLICATIONS

CURRENT SOURCE MIRROR

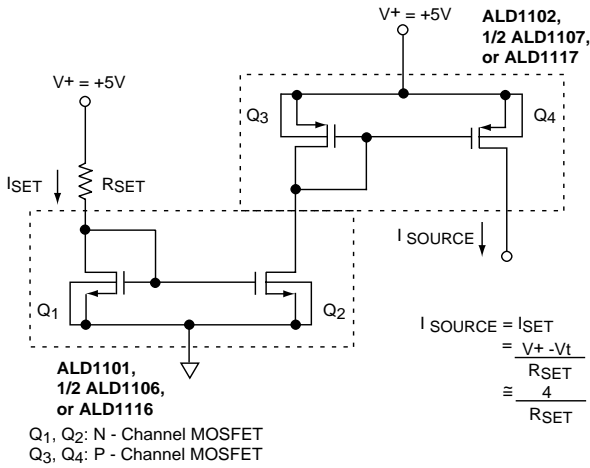

CURRENT SOURCE WITH GATE CONTROL

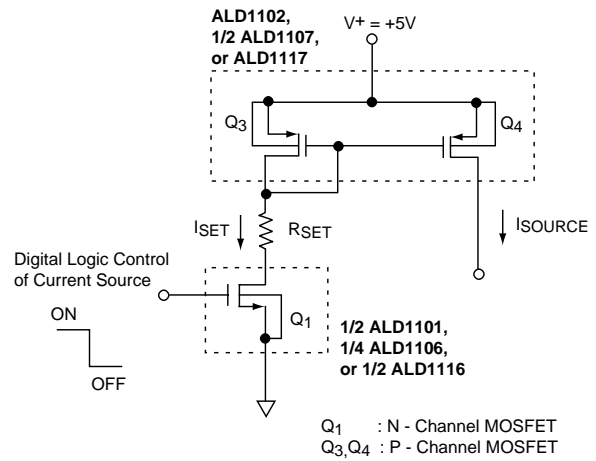

DIFFERENTIAL AMPLIFIER

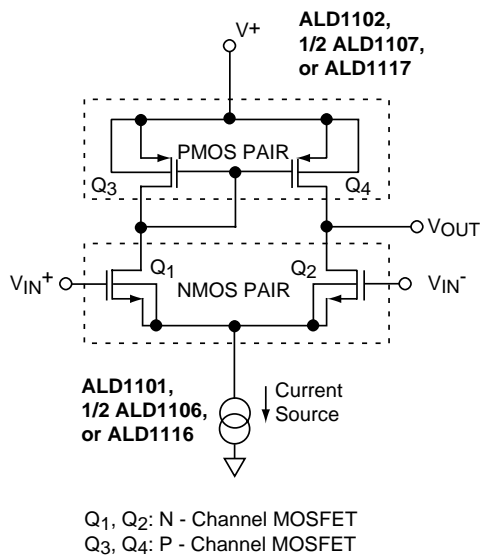

CURRENT SOURCE MULTIPLICATION

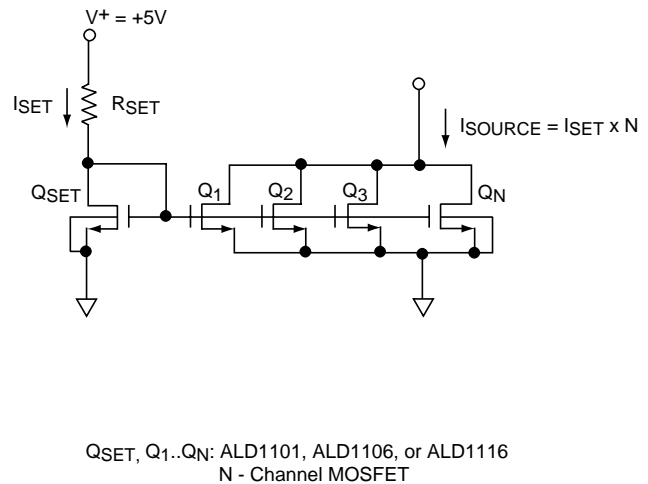

TYPICAL APPLICATIONS (cont.)

BASIC CURRENT SOURCES

N- CHANNEL CURRENT SOURCE

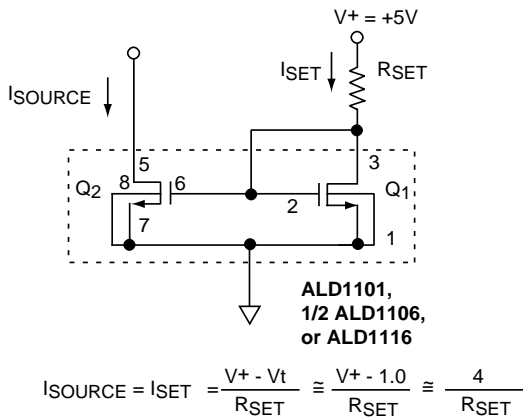

Q1, Q2 : N - Channel MOSFET

P- CHANNEL CURRENT SOURCE

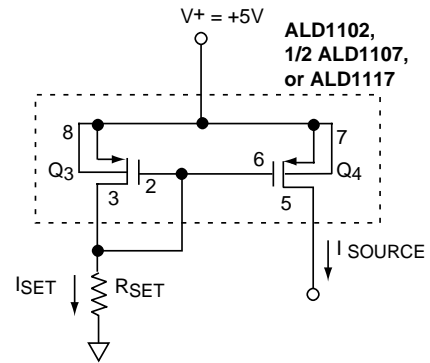

Q3, Q4: P - Channel MOSFET

CASCODE CURRENT SOURCES

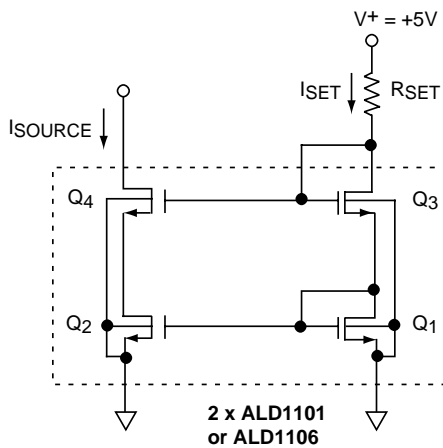

Q1, Q2, Q3, Q4: N - Channel MOSFET
(ALD1101 or ALD1103)

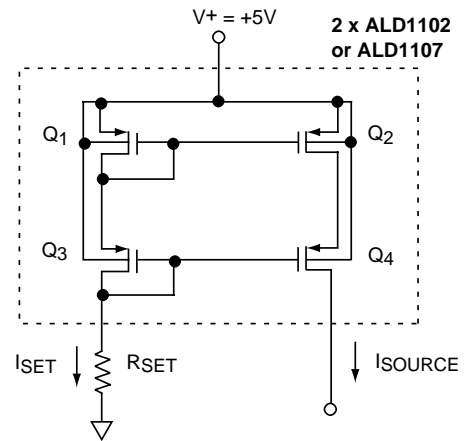

$$I_{SOURCE} = I_{SET} = \frac{V^+ - 2V_t}{R_{SET}} \cong \frac{3}{R_{SET}}$$

Q1, Q2, Q3, Q4: P - Channel MOSFET
(ALD1102 or ALD1103)

SOIC-8 PACKAGE DRAWING

8 Pin Plastic SOIC Package

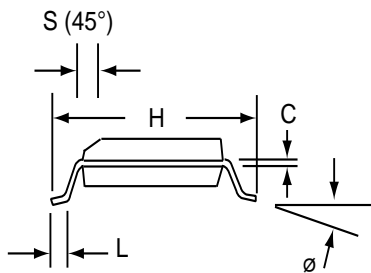
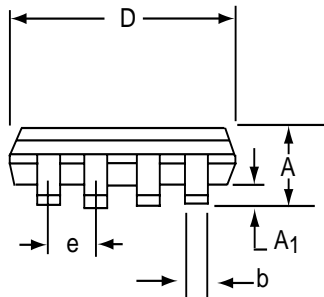
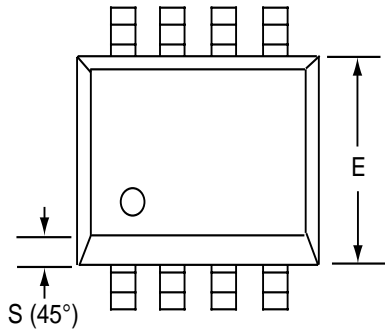

Dim	Millimeters		Inches	
	Min	Max	Min	Max
A	1.35	1.75	0.053	0.069
A ₁	0.10	0.25	0.004	0.010
b	0.35	0.45	0.014	0.018
C	0.18	0.25	0.007	0.010
D-8	4.69	5.00	0.185	0.196
E	3.50	4.05	0.140	0.160
e	1.27 BSC		0.050 BSC	
H	5.70	6.30	0.224	0.248
L	0.60	0.937	0.024	0.037
∅	0°	8°	0°	8°
S	0.25	0.50	0.010	0.020

PDIP-8 PACKAGE DRAWING

8 Pin Plastic DIP Package

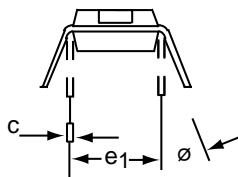
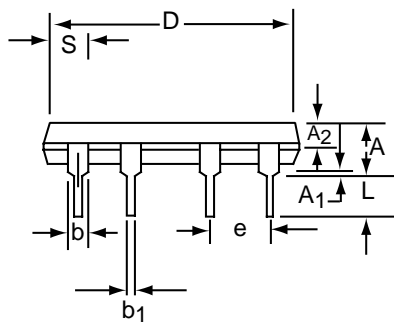
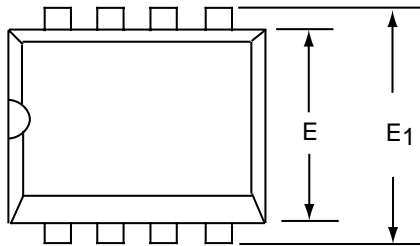

Dim	Millimeters		Inches	
	Min	Max	Min	Max
A	3.81	5.08	0.105	0.200
A₁	0.38	1.27	0.015	0.050
A₂	1.27	2.03	0.050	0.080
b	0.89	1.65	0.035	0.065
b₁	0.38	0.51	0.015	0.020
c	0.20	0.30	0.008	0.012
D-8	9.40	11.68	0.370	0.460
E	5.59	7.11	0.220	0.280
E₁	7.62	8.26	0.300	0.325
e	2.29	2.79	0.090	0.110
e₁	7.37	7.87	0.290	0.310
L	2.79	3.81	0.110	0.150
S-8	1.02	2.03	0.040	0.080
ø	0°	15°	0°	15°

CERDIP-8 PACKAGE DRAWING

8 Pin CERDIP Package

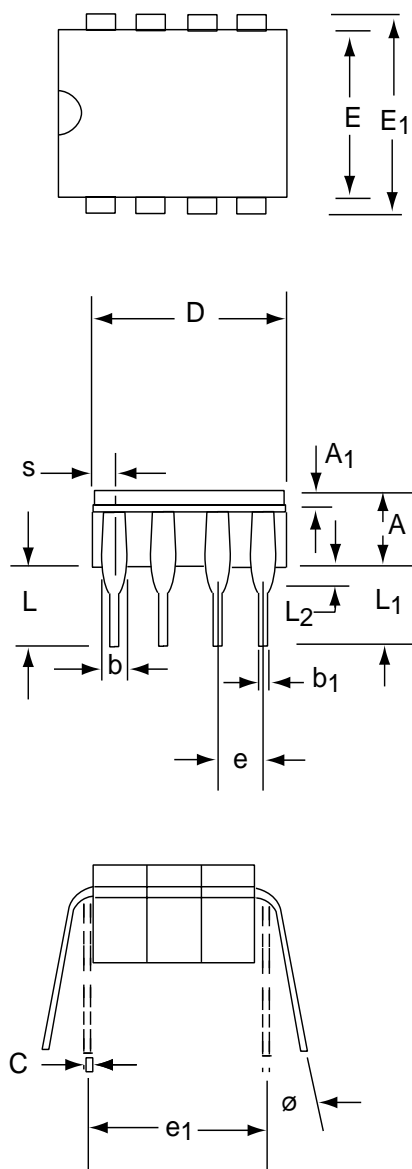

Dim	Millimeters		Inches	
	Min	Max	Min	Max
A	3.55	5.08	0.140	0.200
A₁	1.27	2.16	0.050	0.085
b	0.97	1.65	0.038	0.065
b₁	0.36	0.58	0.014	0.023
C	0.20	0.38	0.008	0.015
D-8	--	10.29	--	0.405
E	5.59	7.87	0.220	0.310
E₁	7.73	8.26	0.290	0.325
e	2.54 BSC		0.100 BSC	
e₁	7.62 BSC		0.300 BSC	
L	3.81	5.08	0.150	0.200
L₁	3.18	--	0.125	--
L₂	0.38	1.78	0.015	0.070
S	--	2.49	--	0.098
∅	0°	15°	0°	15°

SOIC-14 PACKAGE DRAWING

14 Pin Plastic SOIC Package

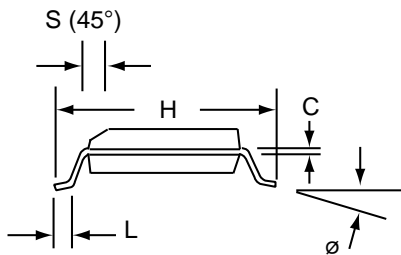
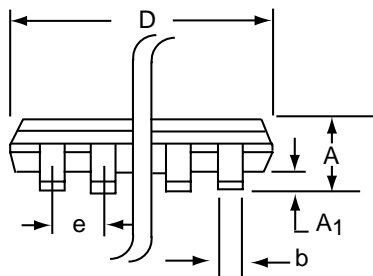
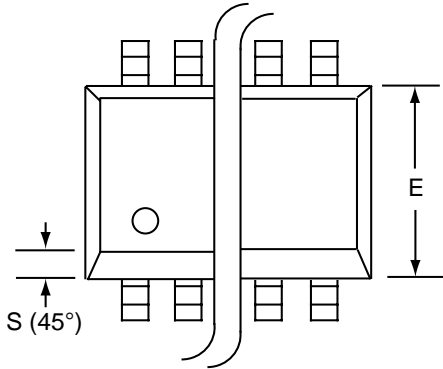

Dim	Millimeters		Inches	
	Min	Max	Min	Max
A	1.35	1.75	0.053	0.069
A ₁	0.10	0.25	0.004	0.010
b	0.35	0.45	0.014	0.018
C	0.18	0.25	0.007	0.010
D-14	8.55	8.75	0.336	0.345
E	3.50	4.05	0.140	0.160
e	1.27 BSC		0.050 BSC	
H	5.70	6.30	0.224	0.248
L	0.60	0.937	0.024	0.037
∅	0°	8°	0°	8°
S	0.25	0.50	0.010	0.020

PDIP-14 PACKAGE DRAWING

14 Pin Plastic DIP Package

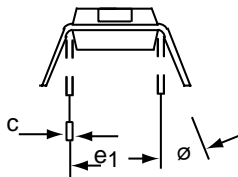
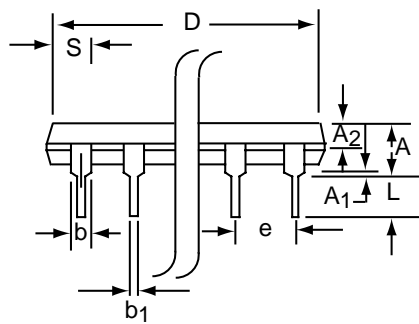
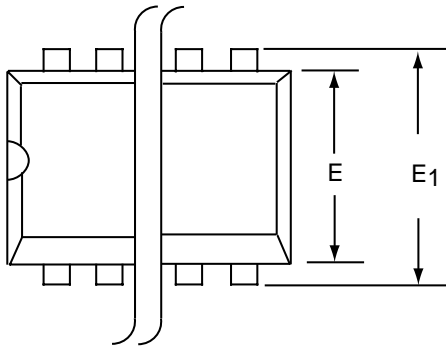

Dim	Millimeters		Inches	
	Min	Max	Min	Max
A	3.81	5.08	0.105	0.200
A1	0.38	1.27	0.015	0.050
A2	1.27	2.03	0.050	0.080
b	0.89	1.65	0.035	0.065
b1	0.38	0.51	0.015	0.020
c	0.20	0.30	0.008	0.012
D-14	17.27	19.30	0.680	0.760
E	5.59	7.11	0.220	0.280
E1	7.62	8.26	0.300	0.325
e	2.29	2.79	0.090	0.110
e1	7.37	7.87	0.290	0.310
L	2.79	3.81	0.110	0.150
S-14	1.02	2.03	0.040	0.080
ø	0°	15°	0°	15°

CERDIP-14 PACKAGE DRAWING

14 Pin CERDIP Package

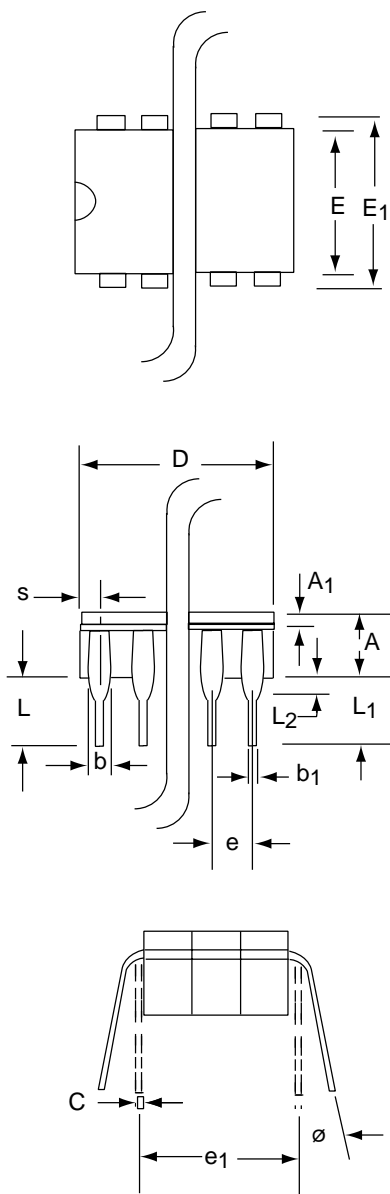

Dim	Millimeters		Inches	
	Min	Max	Min	Max
A	3.55	5.08	0.140	0.200
A₁	1.27	2.16	0.050	0.085
b	0.97	1.65	0.038	0.065
b₁	0.36	0.58	0.014	0.023
C	0.20	0.38	0.008	0.015
D-14	--	19.94	--	0.785
E	5.59	7.87	0.220	0.310
E₁	7.73	8.26	0.290	0.325
e	2.54 BSC		0.100 BSC	
e₁	7.62 BSC		0.300 BSC	
L	3.81	5.08	0.150	0.200
L₁	3.18	--	0.125	--
L₂	0.38	1.78	0.015	0.070
S	--	2.49	--	0.098
∅	0°	15°	0°	15°