

Excellent Integrated System Limited

Stocking Distributor

Click to view price, real time Inventory, Delivery & Lifecycle Information:

[Molex Connector Corporation](#)
[0330123003](#)

For any questions, you can email us directly:

sales@integrated-circuit.com

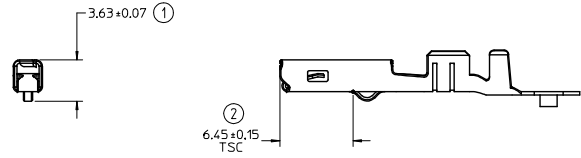

DIMENSIONS FOR LARGE POLARIZATION RIB TERMINAL ONLY

STAMP PLATING TYPE
Sn-TIN, Au-GOLD OR
Ag-SILVER IN THIS
AREA

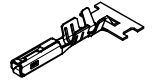
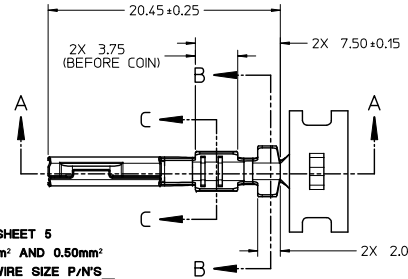

SCALE 2:1



SECTION B-B
SCALE 5:1



SECTION C-C
SCALE 5:1

CARRIER BUMP DIRECTION
POINTS DOWN FOR TIN PLATED TERMINALS
POINTS UP FOR PRECIOUS PLATED TERMINALS

NOTES: (UNLESS OTHERWISE SPECIFIED)

1. MATING TERMINAL SHOWN ON SD-33000-001
2. MATERIAL: ASTM B422, UNS C19025, HR04
THICKNESS: 0.30 mm ±0.01
TEMPER: FULL HARD (REF)
TENSILE: 496 MIN MPa
3. TIN PLATED TERMINAL FINISH:
OVERALL UNDERPLATE ELECTRODEPOSITED NICKEL
OVERALL ELECTRODEPOSITED REFLOW TIN
4. GOLD PLATED TERMINAL FINISH:
OVERALL UNDERPLATE ELECTRODEPOSITED DUCTILE SULFAMATE NICKEL
CONTACT AREA - ELECTRODEPOSITED GOLD
GRP AREA - ELECTRODEPOSITED 100% TIN MATTE FINISH
5. SILVER PLATED TERMINAL FINISH:
OVERALL UNDERPLATE ELECTRODEPOSITED DUCTILE SULFAMATE NICKEL
CONTACT AREA - ELECTRODEPOSITED PURE SILVER (0.5% MAX IMPURITIES) SEM-BRIGHT FINISH
- SILVER ANTI-TARNISH + EVABRITE
GRP AREA - ELECTRODEPOSITED 100% TIN MATTE FINISH
6. MEETS PERFORMANCE SPECIFICATION FOR CABLE TO TERMINAL ELECTRICAL CRIMPS PER SAE/USCAR-21 (8/2000)
7. MEETS PERFORMANCE STANDARD FOR AUTOMOTIVE ELECTRICAL CONNECTOR SYSTEMS FOR SAE/USCAR-2, REV. 4 (TEMP CLASS 3) (5/2004)
8. MEETS ELECTRICAL CONNECTION SYSTEM DESIGN SPECIFICATION (ISDS) REV.11 (5/2002)
9. MEETS FIELD CORRELATED LIFE TEST (FCLT) PER SAE/USCAR-20 (6/2004)
10. MEETS WIRING COMPONENT DESIGN GUIDELINES SAE/USCAR-12 REV 2 (12/2001)
11. TSC ON A DIMENSION TO BE INTERPRETED AS DISTANCE TO A THEORETICAL SHARP CORNER AS IF THE RADIUS WERE NOT PRESENT
12. REFERENCE 9786-1474-AAB FOR LARGE POLARIZATION RIB CAVITY SPECIFICATION
13. INSERTION FORCE (TINI AVG. FROM PV TESTING - 3.8N LARGE POLARIZATION RIB
3.5N SMALL POLARIZATION RIB (REFERENCE))
14. ALL DIMENSIONS EXCEPT (1), (2), (3) & (4) ARE COMMON TO BOTH SMALL AND LARGE POLARIZATION RIB TERMINALS
15. REFERENCE PK-31000-516 FOR REEL DIRECTION
16. REFERENCE AS-33012-002 FOR CRIMP INFORMATION

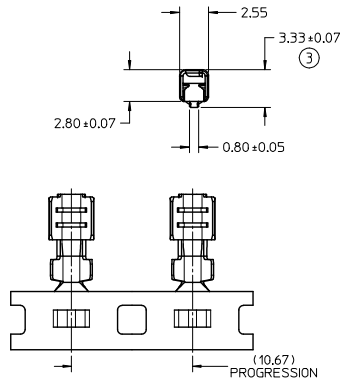

SEE SHEET 5
0.35mm² AND 0.50mm²
ISO WIRE SIZE P/N/S
33012-2004/3004
33001-4005/5005

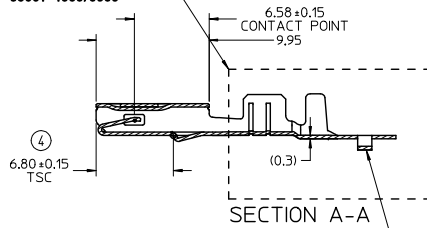

ENTER DESCRIPTION EC NO: 0A02014-0473 DRAWN BY: JENNINGS01 2013/09/18 CHKD: APPROBUSER 2014/01/03	QUALITY SYMBOLS 	GENERAL TOLERANCES (UNLESS SPECIFIED)		DIMENSION STYLE		SCALE	DESIGN UNITS	THIRD ANGLE PROJECTION		
				MM ONLY		4:1	METRIC			
		4 PLACES ± --- ± ---		DRAWN BY L. PULLIAM DATE 2005/06/21		TITLE				
		3 PLACES ± 0.005 ± ---		CHECKED BY A. DHIR DATE 2005/06/21		MX150 RECEPTACLE TERMINAL				
2 PLACES ± 0.10 ± ---		1 PLACE ± 0.3 ± ---		APPROVED BY B. MOSER DATE 2005/06/22		MOLEX INCORPORATED				
ANGULAR ± 3°		DRAFT WHERE APPLICABLE MUST REMAIN WITHIN DIMENSIONS		SEE TABLE		DOCUMENT NO. SD-33012-002		SHEET NO. 1 OF 5		
THIS DRAWING CONTAINS INFORMATION THAT IS PROPRIETARY TO MOLEX INCORPORATED AND SHOULD NOT BE USED WITHOUT WRITTEN PERMISSION										

FAMILY	GENDER	SEALING	PLATING	PART NUMBER	PAYOFF DIRECTION	GRIP CODE	WIRE SIZES*	A +0.30	B ±0.30	C +0.30	D ±0.30	SPECIAL CHARACTERISTICS
MX150	RECEPTACLE	MAT SEAL	Sn	33012-2001	RIGHT (B)	14	16/14AWG	3.9	4.4	1.7	1.6	HIGH PERFORMANCE Sn
				33012-3001	LEFT (D)		150-2.00mm ²					
				33012-2002	RIGHT (B)	18	20/18AWG	3.3	3.1	1.3	1.4	
				33012-3002	LEFT (D)		0.75-1.00mm ²					
				33012-2003	RIGHT (B)	22	22AWG	2.5	2.6	0.9	1.0	
				33012-3003	LEFT (D)							
			33012-2004	RIGHT (B)	M3	0.35-0.50mm ²	2.5	2.7	0.9	1.54 ±0.1		
			33012-3004	LEFT (D)								
			33001-2003	RIGHT (B)	14	16/14AWG	3.9	4.4	1.7	1.6	HIGH PERFORMANCE Au	
			33001-3003	LEFT (D)		150-2.00mm ²						
			33001-2004	RIGHT (B)	18	20/18AWG	3.3	3.1	1.3	1.4		
			33001-3004	LEFT (D)		0.75-1.00mm ²						
			33001-2005	RIGHT (B)	22	22AWG	2.5	2.6	0.9	1.0		
			33001-3005	LEFT (D)								
			33001-2006	RIGHT (B)	M3	0.35-0.50mm ²	2.5	2.7	0.9	1.54 ±0.1		
			33001-3006	LEFT (D)								
			33001-4001	RIGHT (B)	14	16/14AWG	3.9	4.4	1.7	1.6	HIGH PERFORMANCE Ag	
			33001-5001	LEFT (D)		150-2.00mm ²						
			33001-4002	RIGHT (B)	18	20/18AWG	3.3	3.1	1.3	1.4		
			33001-5002	LEFT (D)		0.75-1.00mm ²						
			33001-4003	RIGHT (B)	22	22AWG	2.5	2.6	0.9	1.0		
			33001-5003	LEFT (D)								
			33001-4005	RIGHT (B)	M3	0.35-0.50mm ²	2.5	2.7	0.9	1.54 ±0.1		
			33001-5005	LEFT (D)								
LARGE POLARIZATION RIB - NOT TO BE USED IN MX150 SEALED CONNECTORS												
MX150	RECEPTACLE	UNSEALED	Sn	33012-2021	RIGHT (B)	14	16/14AWG	3.9	4.4	1.7	1.6	HIGH PERFORMANCE Sn
				33012-3021	LEFT (D)		150-2.00mm ²					
				33012-2022	RIGHT (B)	18	20/18AWG	3.3	3.1	1.3	1.4	
				33012-3022	LEFT (D)		0.75-1.00mm ²					
				33012-2023	RIGHT (B)	22	22AWG	2.5	2.6	0.9	1.0	
				33012-3023	LEFT (D)							
			33001-2021	RIGHT (B)	14	16/14AWG	3.9	4.4	1.7	1.6	HIGH PERFORMANCE Au	
			33001-3021	LEFT (D)		150-2.00mm ²						
			33001-2022	RIGHT (B)	18	20/18AWG	3.3	3.1	1.3	1.4		
			33001-3022	LEFT (D)		0.75-1.00mm ²						
			33001-2023	RIGHT (B)	22	22AWG	2.5	2.6	0.9	1.0		
			33001-3023	LEFT (D)								
			33001-4021	RIGHT (B)	14	16/14AWG	3.9	4.4	1.7	1.6	HIGH PERFORMANCE Ag	
			33001-5021	LEFT (D)		150-2.00mm ²						
			33001-4022	RIGHT (B)	18	20/18AWG	3.3	3.1	1.3	1.4		
			33001-5022	LEFT (D)		0.75-1.00mm ²						
			33001-4023	RIGHT (B)	22	22AWG	2.5	2.6	0.9	1.0		
			33001-5023	LEFT (D)								

* REFERENCE AS-33012-002 FOR SPECIFIC WIRE TYPES

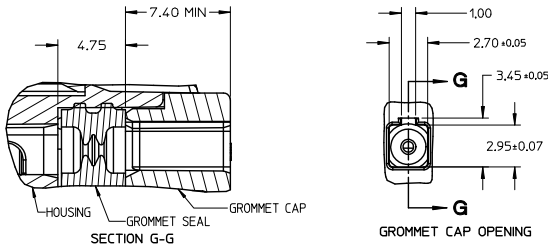

GROGMET SEAL / CAP CONFIGURATION TO MODIFY LARGE POLARIZATION RIB CAVITY TO ACCEPT SMALL POLARIZATION RIB APPLICATIONS

ENTER DESCRIPTION EC NO: 0A02014-0473 DRAWN BY: JENNINGS01 2013/09/18 CHKD: APPR: BMOSER 2014/06/22 REV	QUALITY SYMBOLS 	GENERAL TOLERANCES (UNLESS SPECIFIED)		DIMENSION STYLE MM ONLY		SCALE METRIC	DESIGN UNITS METRIC	THIRD ANGLE PROJECTION	
		4 PLACES ± 0.10 ± 0.005 3 PLACES ± 0.05 ± 0.005 2 PLACES ± 0.10 ± 0.005 1 PLACE ± 0.3 ± 0.005	mm INCH ± 0.10 ± 0.005 ± 0.05 ± 0.005 ± 0.10 ± 0.005 ± 0.3 ± 0.005	DRAWN BY: L. PULLIAM DATE: 2005/06/21	CHECKED BY: A. DHIR DATE: 2005/06/21	TITLE MX150 RECEPTACLE TERMINAL			
		ANGULAR ± 3°		APPROVED BY: B. MOSER DATE: 2005/06/22	MOLEX INCORPORATED				
		DRAFT WHERE APPLICABLE MUST REMAIN WITHIN DIMENSIONS		MATERIAL NO. SEE TABLE SIZE C	DOCUMENT NO. SD-33012-002	SHEET NO. 2 OF 5			

THIS CHECKING - AID IS FOR SMALL POLARIZATION RIB TERMINALS ONLY

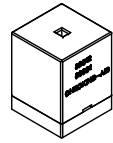

CHECKING - AID ASSEMBLY
SCALE 1:1

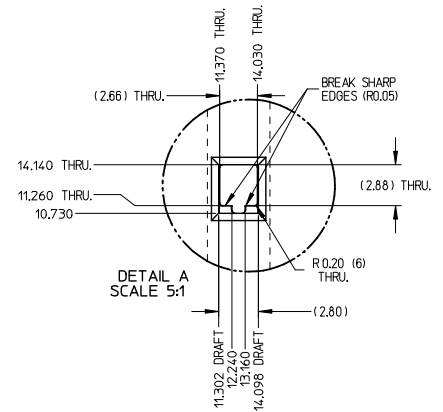
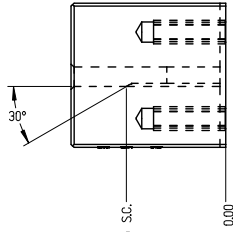
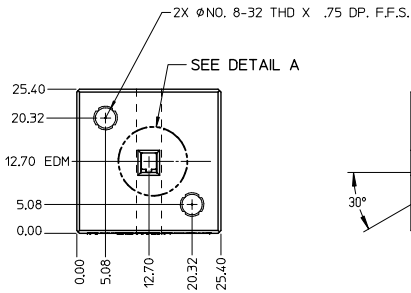

DETAIL A
SCALE 5:1

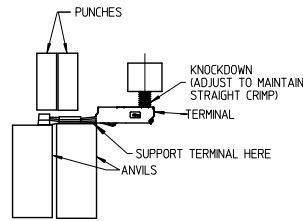
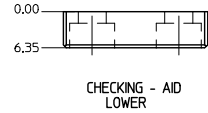
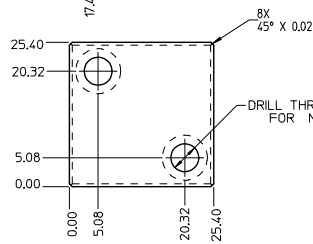
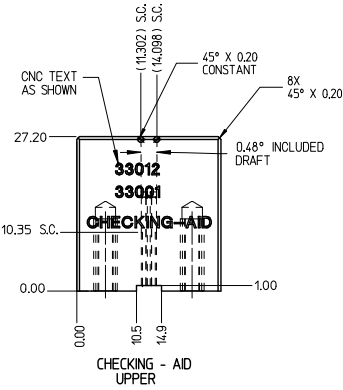

CRIMP REQUIREMENTS:

1. CRIMP STRAIGHTNESS MUST BE MAINTAINED. USE A KNOCKDOWN TOOL LOCATED AS SHOWN. TERMINAL BOX MUST NOT BE DEFORMED.
2. AFTER CRIMPING, THE CRIMPED TERMINAL (AND UP TO 5 mm OF WIRE PAST THE INSULATOR CUTOFF TAB) MUST FIT FREELY INTO THE CHECKING-AID SHOWN ON THIS PAGE.
3. FOR OTHER MECHANICAL REQUIREMENTS ON CRIMPED TERMINALS, REFER TO SAE/USCAR-21 (5-13-02) SECTIONS 4.2 (VISUAL INSPECTION), 4.2 (CROSS SECTION ANALYSIS) AND 4.4 (CONDUCTOR CRIMP PULLOUT FORCE).

UPPER & LOWER
CHECKING-AID
A2 TOOL STEEL
HARDEN & GRIND
ROCKWELL "C" 56-58

ENTER DESCRIPTION EC NO: UAU2014-0473 DRAWING NO: WJMS01 2013/09/16 CHKD: APPROB/MOSER REV	QUALITY SYMBOLS ▽=0 ▽=0 ▽=0	GENERAL TOLERANCES (UNLESS SPECIFIED)		DIMENSION STYLE MM ONLY		SCALE 2:1	DESIGN UNITS METRIC	THIRD ANGLE PROJECTION	
		mm	INCH	DRAWN BY L. PULLIAM	DATE 2005/06/21	TITLE MX150 RECEPTACLE TERMINAL	MOLEX INCORPORATED		
		4 PLACES ± ---	± ---	CHECKED BY A. DHIR	DATE 2005/06/21	MATERIAL NO. SD-33012-002			
		3 PLACES ± 0.005	± ---	APPROVED BY B. MOSER	DATE 2005/06/22	DOCUMENT NO. SD-33012-002			
		2 PLACES ± 0.10	± ---	DRAFT WHERE APPLICABLE MUST REMAIN WITHIN DIMENSIONS		SHEET NO. 3 OF 5			
		1 PLACE ± 0.3	± ---	SIZE SEE TABLE		THIS DRAWING CONTAINS INFORMATION THAT IS PROPRIETARY TO MOLEX INCORPORATED AND SHOULD NOT BE USED WITHOUT WRITTEN PERMISSION			
		ANGULAR ± 3°							

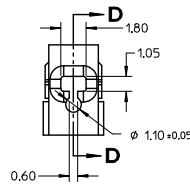
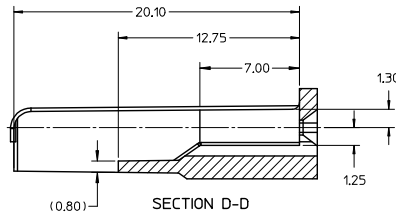
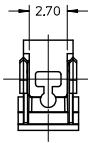

- NOTES: UNLESS OTHERWISE SPECIFIED
1. TOLERANCES: LINEAR ± 0.10
ANGULAR $\pm 3^\circ$
 2. ALL DRAFT WITHIN TOLERANCE.
 3. MAX RADI ON ALL CORNERS SHOWN SHARP: 0.10
 4. MAX FLASH PERMISSIBLE: 0.1
 5. EJECTOR PIN MARKS PERMISSIBLE IF FLUSH TO 0.25 BELOW SURFACE.
 6. MATERIAL: HOUSING/FINGER SPECIFICATION ENGINEERED FOR MATERIAL WITH THE FOLLOWING PROPERTIES:
A. FLEXURAL MODULUS = 4,500 TO 9,400 MPa
PER ASTM TEST D790
B. ELONGATION AT YIELD = 2.3% OR BETTER
PER ASTM TEST D638 TYPE V
 7. CAVITY SPEC FOR USE ONLY WITH MOLEX RECEPTACLE
TERMINAL PART NUMBERS SPECIFIED ELSEWHERE ON THIS DRAWING

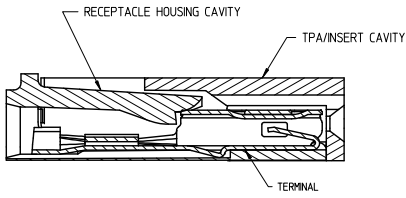
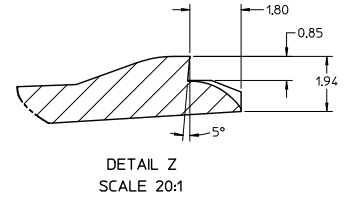
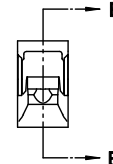
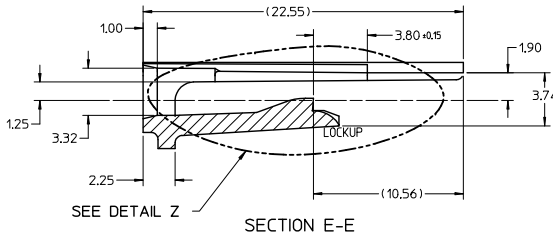
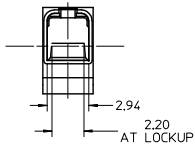

RECEPTACLE CAVITY ASSEMBLED VIEWS FOR SMALL POLARIZATION RIB APPLICATIONS FIG. 1

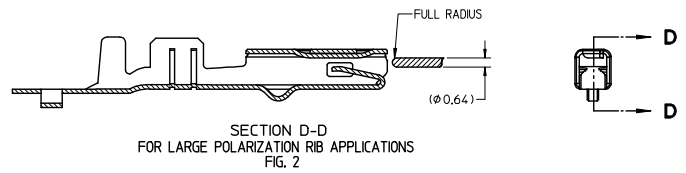
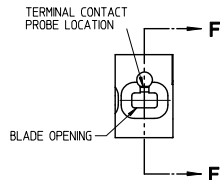

SECTION D-D FOR LARGE POLARIZATION RIB APPLICATIONS FIG. 2

PROBING DOWN THE THROAT MUST USE THIS TERMINAL PROBE
FOR PROBING INFORMATION REFERENCE MOLEX MX150 APPLICATION SPEC AS-33472-100

PREFERRED PROBING LOCATION IS NOT ON SPRING MEMBER
IF ELECTRICAL CONTINUITY PROBE TOUCHES SPRING MEMBER USE PROBING AS SHOWN IN FIG. 2

ENTER DESCRIPTION EC NO: UAU2014-0473 DRAWN/JENNINGS01 2013/09/18 CHKD: APPERBMOSE 2014/06/03	QUALITY SYMBOLS ▽=0 ▽=0 ▽=0	GENERAL TOLERANCES (UNLESS SPECIFIED)		DIMENSION STYLE MM ONLY		SCALE 5:1	DESIGN UNITS METRIC	THIRD ANGLE PROJECTION	
		mm	INCH	DRAWN BY L. PULLIAM	DATE 2005/06/21	TITLE MX150 RECEPTACLE TERMINAL			
		4 PLACES	± ---	± ---	CHECKED BY A. DHIR	DATE 2005/06/21	MOLEX INCORPORATED		
		3 PLACES	± 0.005	± ---	APPROVED BY B. MOSER	DATE 2005/06/22	DOCUMENT NO. SD-33012-002		
		2 PLACES	± 0.10	± ---	MATERIAL NO.		SHEET NO. 4 OF 5		
		1 PLACE	± 0.3	± ---	SIZE SEE TABLE		THIS DRAWING CONTAINS INFORMATION THAT IS PROPRIETARY TO MOLEX INCORPORATED AND SHOULD NOT BE USED WITHOUT WRITTEN PERMISSION		
		ANGULAR		± 3°					
		DRAFT WHERE APPLICABLE MUST REMAIN WITHIN DIMENSIONS							

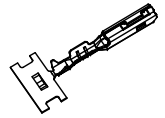

ISO VIEW
SCALE 2:1

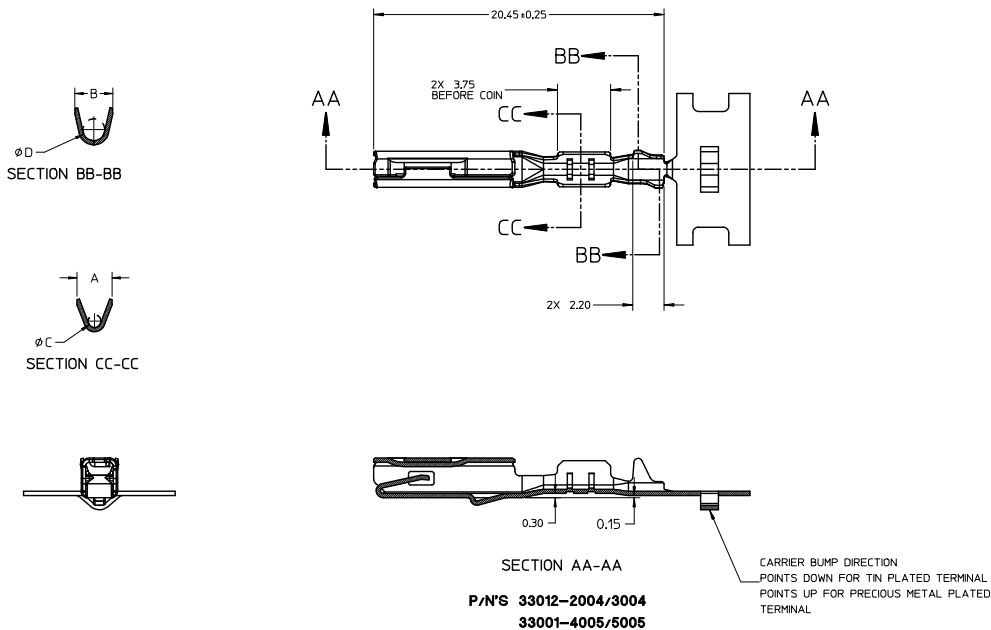

P/N'S **33012-2004/3004**
33001-4005/5005

ENTER DESCRIPTION EC NO: 0402014-0473 DRAWN/JENNINGS01 2013/09/18 CHKD: APPIRB/MOSER 2014/06/03	QUALITY SYMBOLS ∇=0 ∇=0 ∇=0	GENERAL TOLERANCES (UNLESS SPECIFIED)		DIMENSION STYLE MM ONLY		SCALE 5:1	DESIGN UNITS METRIC	THIRD ANGLE PROJECTION	
		4 PLACES ± --- ± ---	mm	INCH	DRAWN BY L. PULLIAM	DATE 2005/06/21	TITLE MX150 RECEPTACLE TERMINAL		
		3 PLACES ± 0.005 ± ---	2 PLACES ± 0.10 ± ---	1 PLACE ± 0.3 ± ---	CHECKED BY A. DHIR	DATE 2005/06/21	MOLEX INCORPORATED		
		ANGULAR ± 3°		DRAFT WHERE APPLICABLE MUST REMAIN WITHIN DIMENSIONS	APPROVED BY B. MOSER	DATE 2005/06/22	MATERIAL NO. SEE TABLE	DOCUMENT NO. SD-33012-002	SHEET NO. 5 OF 5