

## Excellent Integrated System Limited

Stocking Distributor

Click to view price, real time Inventory, Delivery & Lifecycle Information:

[Molex Connector Corporation](#)

[15-82-0649](#)

For any questions, you can email us directly:

[sales@integrated-circuit.com](mailto:sales@integrated-circuit.com)

**NOTES:**  
 1. CARD SLOT ACCEPTS P.C. BOARDS  $.050 \pm .004 / -.003$  THICK, MEASURED OVER CONTACT PADS.  
 2. LOCATION OF LOWER CORNER OF MODULE BOARD.  
 3. PRODUCT SPEC. PS-78954 APPLIES.  
 4. CENTER PEG IS AN INTERFERENCE FIT TO RECOMMENDED P.C. BOARD HOLE.

**MATERIALS:**  
 HOUSING: LCP, GLASS FILLED, 94V-0. COLOR: BLACK.  
 LATCH: STAINLESS STEEL.  
 TERMINAL: PHOSPHOR BRONZE, POST PLATED  
 200  $\mu\text{m}$  / (5.08  $\mu\text{m}$ ) MINIMUM TIN IN CONTACT AREA AND 150  $\mu\text{m}$  / (3.81  $\mu\text{m}$ ) MINIMUM TIN IN TAIL AREA OVER 50  $\mu\text{m}$  / (1.27  $\mu\text{m}$ ) MINIMUM NICKEL OVERALL.  
 THE PRIMARY SHIPPING CARTON WILL BE LABELED 'COMPLIANT TO ROHS DIRECTIVE 2002/95/EC AND ELV ANNEX II OF DIRECTIVE 2000/53/EC'. CARTONS WITHOUT THIS LABEL MAY CONTAIN PRODUCT WITH LEAD.

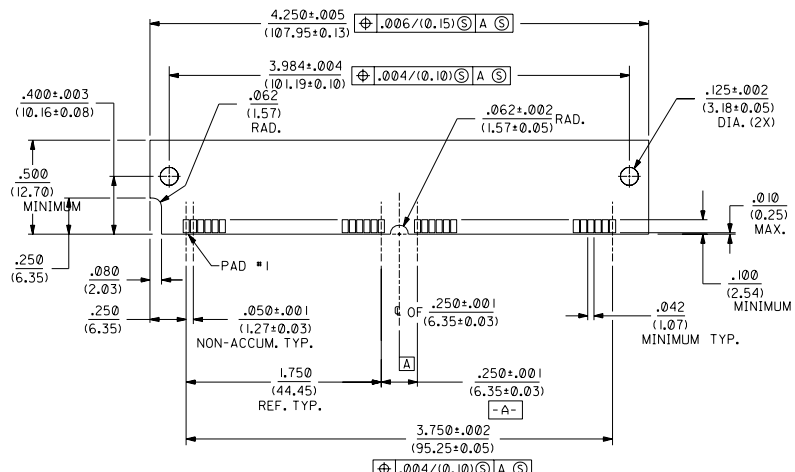

"SIMM" P.C. BOARD LAYOUT

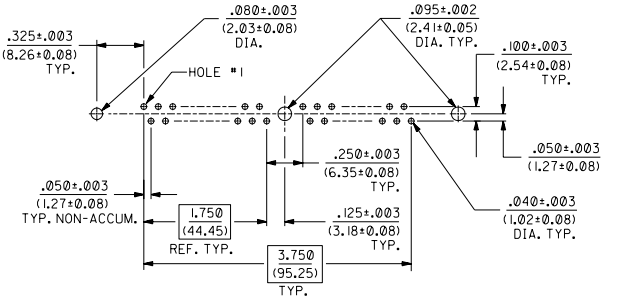

RECOMMENDED SOCKET P.C. BOARD HOLE PATTERN

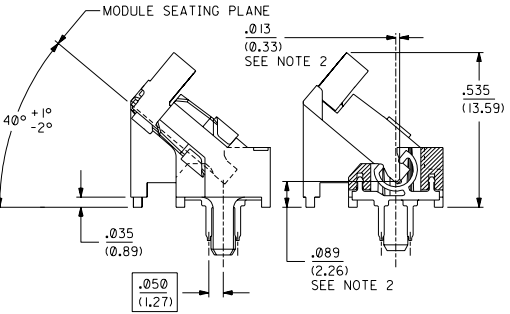
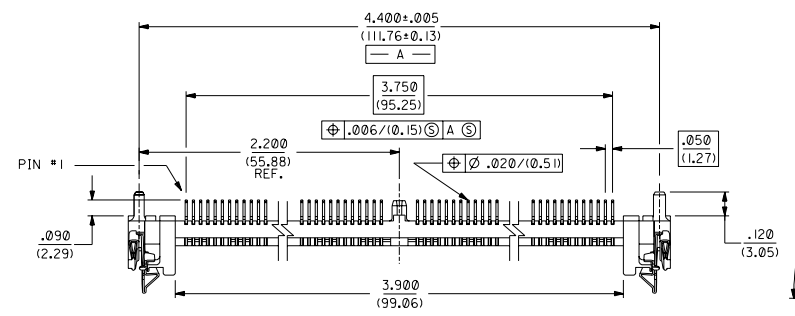

END VIEW SECTION A-A

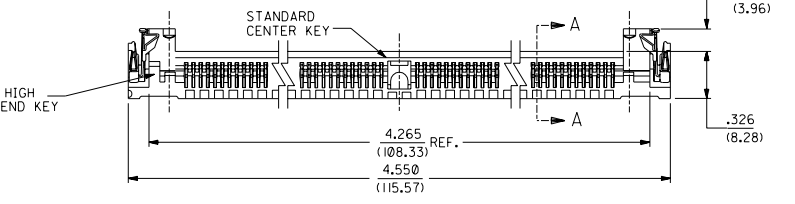

C	LEAD FREE UCP2004-RB2 RWHITE 84/03/03
B	REVISED PER ECH U51393 GMY 7-25-95
A	RELEASE PER ECH #US0845 DKS 2-23-95

DIMENSIONS SHOWN (METRIC) INCH		UNLESS OTHERWISE SPECIFIED		TOLERANCES IN MILLIMETERS	
1 PLACE	± .010	---	---	± 0.10	---
2 PLACE	± .014	± 0.25	---	± 0.25	---
3 PLACE	---	± 0.36	---	± 0.36	---
DRAFT ANGLE SPECIFIABLE MUST REMAIN WITHIN DIMENSIONS					
DRG. NO.	DKS	CHKD. BY	SCALE	2:1	DATE
FILE NAME	S1897646	DATE	SCALE	2:1	DATE
PART NO. 15-82-0649			DRG. NO. SDA-78976-7246		
MOLEX INCORPORATED			SHEET NO. 1 OF 1		
DATE 02/23/95			DATE		
THIS DRAWING CONTAINS INFORMATION THAT IS PROPRIETARY TO MOLEX INC. AND SHOULD NOT BE USED WITHOUT WRITTEN PERMISSION, DA					