

Excellent Integrated System Limited

Stocking Distributor

Click to view price, real time Inventory, Delivery & Lifecycle Information:

[Volgen/Division of Kaga Electronics USA](#)
[VHV12-470S06P](#)

For any questions, you can email us directly:

sales@integrated-circuit.com

The VHV series is the first high voltage product supply in the industry to use the latest SMT (surface mount technology) making the size 1/5 to 1/6 from the normal product, with an adjustable output voltage type mid-high voltage DC-DC converter. Output voltage can be controlled using an external voltage or external adjustable resistor. The VHV series has adopted a 5 side metallic shield, with farther low ripple and low noise.

■ Features

- PCB mounting type
- Output capacity 2W to 2.6W
- Over current protection
- Worlds smallest size device
- Low price
- UL certified product (UL File No. E305960)
- Adopted a 5 sided metallic shield case
- Remote ON/OFF control
- High reliability, long life
- Low ripple noise of 30mVp-p
- Adjustable voltage using an external voltage



■ Model name/Rating

Model name VHV series	Input voltage (Vdc)	Output voltage (Vdc) Note1	Output current (mA)	Load resistance (KΩ) min	Output capacity (W)	Input current (mA) typ	Ripple noise (mVp-p) typ	Case
VHV12-470S06P	10.8 to 13.2	0 to +470	0 to 5.6	83.3	2.6	390	40	M-11
VHV12-470S06N	10.8 to 13.2	0 to -470	0 to 5.6	83.3	2.6	390	40	M-11
VHV12-1.0K2000P	10.8 to 16.5	0 to +1000	0 to 2	500	2.0	280	30	M-11
VHV12-1.0K2000N	10.8 to 16.5	0 to -1000	0 to 2	500	2.0	280	30	M-11
VHV12-1.5K1300P	10.8 to 16.5	0 to +1500	0 to 1.3	1150	2.0	290	30	M-11
VHV12-1.5K1300N	10.8 to 16.5	0 to -1500	0 to 1.3	1150	2.0	290	30	M-11
VHV12-2.0K1000P	10.8 to 16.5	0 to +2000	0 to 1	2000	2.0	340	50	M-11
VHV12-2.0K1000N	10.8 to 16.5	0 to -2000	0 to 1	2000	2.0	340	50	M-11

■ Specifications

Input regulation	0.03% typ.(Regulation of input voltage range)
Load regulation	470V type : 0.08%typ. 1KV, 1.5KV, 2KV type : 0.03% typ(Load current 0 to 100%)
Temp regulation	±0.01%/°C typ.(Temp. regulation (-10°C to +50°C))
Over current protection	Hold back characteristic, auto restart circuit operates at 105% or more.
Output voltage accuracy	Below ±5%(Rated output, rated load, 470V type is Vcont=3.76V, 1KV, 1.5KV, 2KV type is Vcont=4V)
Output voltage control	External voltage is 0V to +4V, or an adjustable resistor with 5KΩ.
ON/OFF control	Available (Between 2pin-5pin :when open=ON, when short=OFF)
Usage temperature range	-10°C to +60°C(Derating required for temp.50°C or higher)
Storage temperature range	-25°C to +85°C
Usage humidity range	20% to 95%RH(Non condensing)
Input/output isolation	Non isolated type (2pin-6pin and case are internally connected .)
MTBF expected value	390,000 to 400,000H min.

Note1: The output voltage can be controlled by impressing the Vcont voltage. Using an adjustable resistor or an external voltage, voltage should be impressed on the Vcont pin in order to control the output voltage. When Vcont voltage=0V the output voltage(residual output voltage) should be less than 0.5% of the max output voltage (at Input/Output rating).

■ Test circuit

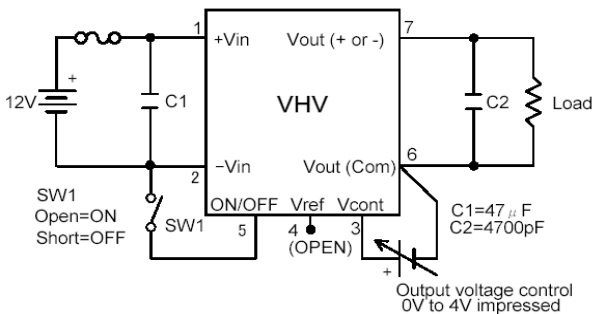

- Warning 1: The input-output ground line and case are internally connected.
- Warning 2: Vref is 4V (When external VR=5KΩ)
- Warning 3: The ON/OFF can be controlled with a transistor.

■ Block diagram

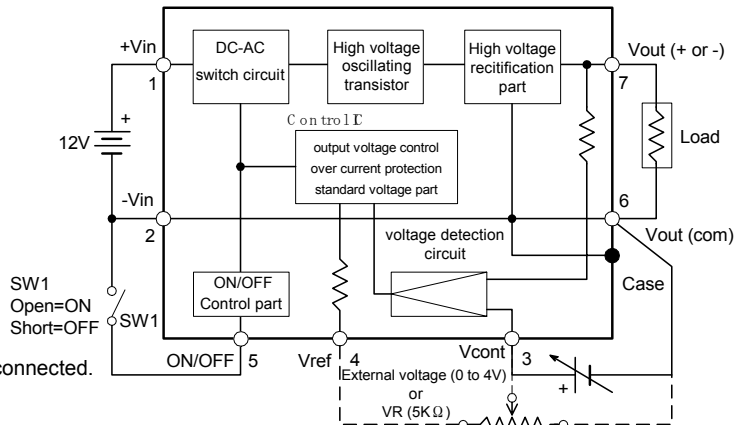



■ Model/Dimensions/Pin configuration (M-11 case)

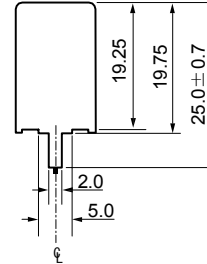
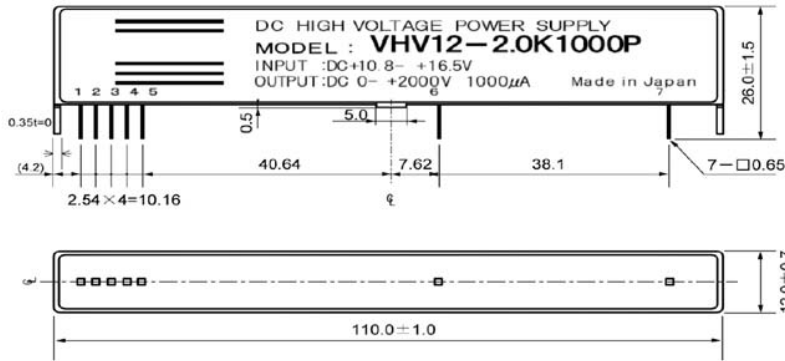

Weight : 65g typ.
Units : mm
Tolerance unless otherwise specified ±0.5

pin-NO.	pin name
1	+Vin
2	-Vin
3	Vcont
4	Vref
5	ON/OFF
6	Vout (com)
7	Vout (+ or -)

- 1) Pins
Material : Phosphorous bronze
Treatment : Ni base Au coating
- 2) Case
Material : Brass
Treatment : Nickel coating

■ Standard usage instructions

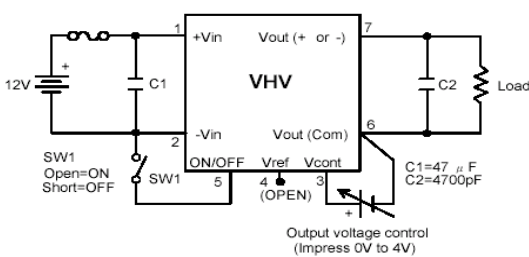

The VHV series does not require any external parts, however when the impedance is high, for example: the distance between the power supply and converter long, the input line is thin, or the input side has a filter then connecting a capacitor C1 to the input side is recommended.
Place the capacitor as close as possible near to the converter pin side, to lower the lead inductance.

■ ON/OFF control

By opening and closing the ON/OFF pin and -Vin pin the external voltage can be turned on and off.

Between the ON/OFF pin (5) and -Vin pin (2)

- 1) Open will turn the output ON
- 2) Short(0 to 1.0V, 1mAmax) will turn the output OFF

The ON/OFF pin is internally pulled up to the +Vin, so be careful of the voltage from the switching element of the ON/OFF pin (photo couplers, transistors, etc)

Keep the (5) open when not using the ON/OFF control.

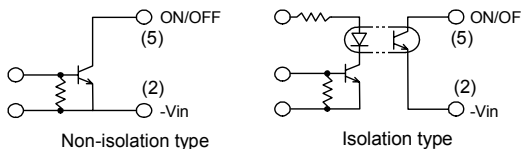

The chattering to the ON/OFF pin will affect the output voltage, so choose one without any chattering. When the output is turned off by ON/OFF control, the residual output voltage should be within 0.5%.