

Excellent Integrated System Limited

Stocking Distributor

Click to view price, real time Inventory, Delivery & Lifecycle Information:

[Phoenix Contact](#)
[1690574](#)

For any questions, you can email us directly:

sales@integrated-circuit.com



Extract from the online catalog

HC-M-KV-M25(11-16)

Order No.: 1690574

The illustration shows version HC-M-KV-M20



<http://eshop.phoenixcontact.de/phoenix/treeViewClick.do?UID=1690574>

Metal screw connection up to 5 bar, thread length: 7 mm, cable diameter: 11 - 16 mm, WAF 27, screw connection: M25

Commercial data	
GTIN (EAN)	 4 017918 822637
sales group	D290
Pack	25 pcs.
Customs tariff	74199990
Catalog page information	Page 521 (PC-2009)

Product notes

WEEE/RoHS-compliant since:
02/16/2006



<http://www.download.phoenixcontact.com>
Please note that the data given here has been taken from the online catalog. For comprehensive information and data, please refer to the user documentation. The General Terms and Conditions of Use apply to Internet downloads.

Technical data

General data	
Type of the screw connection	M25
Cable gland material	Nickel-plated brass
Seal material	Neoprene
Cable seal material	Neoprene
Material, O-ring	NBR

HC-M-KV-M25(11-16) Order No.: 1690574

<http://eshop.phoenixcontact.de/phoenix/treeViewClick.do?UID=1690574>

Wrench size, union nut	27 mm
Wrench size, support	27 mm
Thread type connection side 1	M25
Length of the connecting thread	7.00 mm
External cable diameter	11 mm ... 16 mm
Conductor sealing range	11.00 mm ... 16.00 mm
Tightening torque, union nut	10.00 Nm
Degree of protection	IP68, to 5 bar
Ambient temperature (operation)	-20 °C ... 100 °C

Certificates / Approvals



Certification

GOST

Diagrams/Drawings

Dimensioned drawing

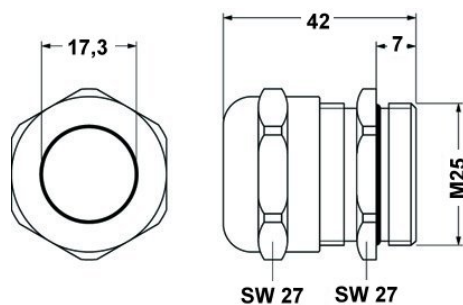

HC-M-KV-M25(11-16) Order No.: 1690574

<http://eshop.phoenixcontact.de/phoenix/treeViewClick.do?UID=1690574>

Address

PHOENIX CONTACT Deutschland GmbH
Flachsmarktstr. 8
32825 Blomberg, Germany
Phone +49 5235 3 12000
Fax +49 5235 3 41200
<http://www.phoenixcontact.de>



© 2010 Phoenix Contact
Technical modifications reserved;