

## Excellent Integrated System Limited

Stocking Distributor

Click to view price, real time Inventory, Delivery & Lifecycle Information:

[Molex Connector Corporation](#)  
[0430450418](#)

For any questions, you can email us directly:

[sales@integrated-circuit.com](mailto:sales@integrated-circuit.com)

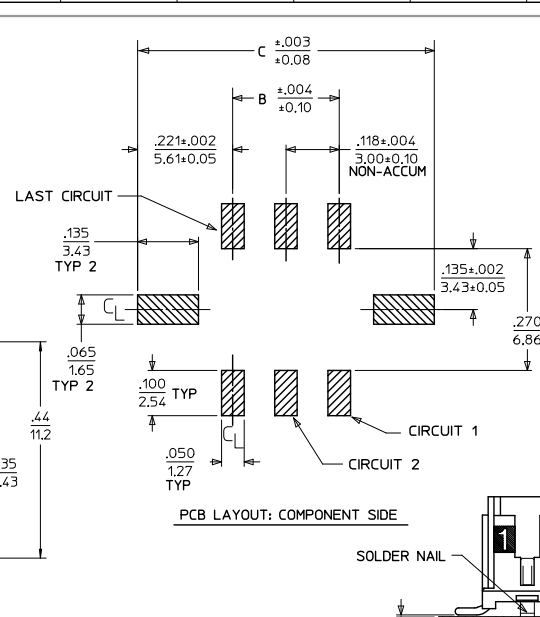
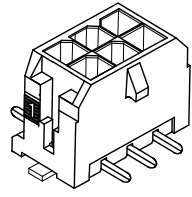
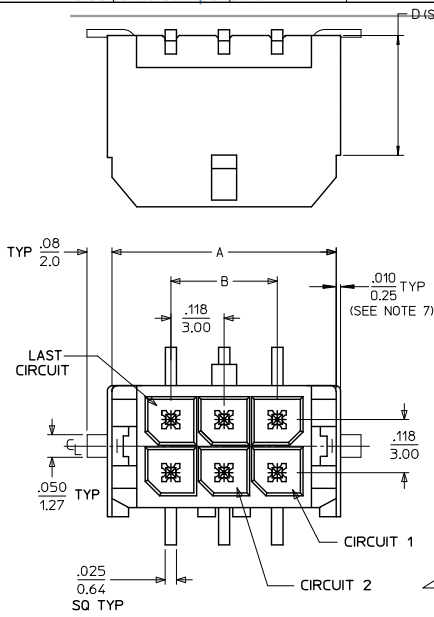

CKTS	A	B	C
02	.262		.441
	6.65	NA	11.20
04	.380	.118	.559
	9.65	3.00	14.20
06	.498	.236	.677
	12.65	6.00	17.20
08	.616	.354	.795
	15.65	9.00	20.20
10	.734	.472	.913
	18.65	12.00	23.20
12	.852	.591	1.031
	21.65	15.00	26.20
14	.970	.709	1.150
	24.65	18.00	29.20
16	1.088	.827	1.268
	27.65	21.00	32.20
18	1.206	.945	1.386
	30.65	24.00	35.20
20	1.325	1.063	1.504
	33.65	27.00	38.20
22	1.443	1.181	1.622
	36.65	30.00	41.20
24	1.561	1.299	1.740
	39.65	33.00	44.20

NOTES:

- HOUSING MATERIAL: GLASS FILLED LIQUID CRYSTAL POLYMER UL94V-0. COLOR: BLACK  
TERMINAL MATERIAL: BRASS ALLOY
- FINISH: A = .000060/(0.00152) MIN. REFLOWED MATTE TIN OVER .000050/(0.00127) MIN. NICKEL PLATE. (FINISH IS BRIGHT IN APPEARANCE, THICKNESS AS APPLIED PRIOR TO REFLOW)  
B = .000015/(0.00038) MIN. SELECT GOLD IN CONTACT AREA, .000100/(0.00254) MIN. SELECT MATTE TIN ON SOLDER TAILS, BOTH OVER .000050/(0.00127) MIN. NICKEL PLATE.  
C = .000030/(0.00076) MIN. SELECT GOLD IN CONTACT AREA, .000100/(0.00254) MIN. SELECT MATTE TIN ON SOLDER TAILS, BOTH OVER .000050/(0.00127) MIN. NICKEL PLATE.  
D = .000100/(0.00254) MIN. MATTE TIN OVER .000050/(0.00127) MIN. NICKEL PLATE.
- PRODUCT SPECIFICATION: PS-43045
- TAPE AND REEL PACK : SEE MOLEX DRAWING PK-70873-05\*\*
- MATES WITH MICRO FIT (3.0) RECEPTACLE SERIES 43025
- THE COPLANARITY DIMENSION IS ESTABLISHED BY PLACING THE ASSEMBLY ON A FLAT SURFACE. THE DISTANCE FROM THAT SURFACE TO THE BOTTOM OF ANY TERMINAL OR SOLDER NAIL MUST NOT EXCEED .006/0.15
- CIRCUIT SIZES 2-6: "D" IS 0.265/6.74 FOR .010/0.25 STEP. CIRCUIT SIZES 8-24: "D" IS .063/1.60 FOR .010/0.25 STEP.
- THIS PART CONFORMS TO CLASS B REQUIREMENTS OF COSMETIC SPECIFICATION PS-45499-002.

CKTS	FINISH A MATERIAL NO:	FINISH B MATERIAL NO:	FINISH C MATERIAL NO:	FINISH D MATERIAL NO:
02	43045-0218	43045-0219	43045-0220	43045-0118
04	43045-0418	43045-0419	43045-0420	43045-0318
06	43045-0618	43045-0619	43045-0620	43045-0518
08	43045-0818	43045-0819	43045-0820	43045-0718
10	43045-1018	43045-1019	43045-1020	43045-0918
12	43045-1218	43045-1219	43045-1220	43045-1118
14	43045-1418	43045-1419	43045-1420	43045-1318
16	43045-1618	43045-1619	43045-1620	43045-1518
18	43045-1818	43045-1819	43045-1820	43045-1718
20	43045-2018	43045-2019	43045-2020	43045-1918
22	43045-2218	43045-2219	43045-2220	43045-2118
24	43045-2418	43045-2419	43045-2420	43045-2318

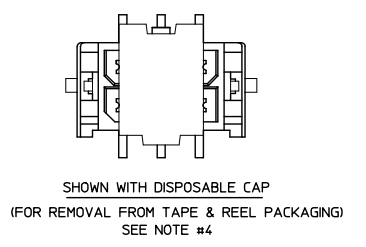
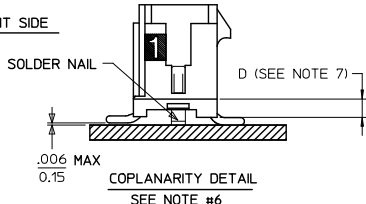

REVISE FINISH A REC NO: UCP2016-0464 DRAWN: JPOX 2015/08/20 CHKD: SMOSEK 2015/08/20 APPROV: SMITH 2015/11/19 G2	QUALITY SYMBOLS 	GENERAL TOLERANCES (UNLESS SPECIFIED) mm INCH	DIMENSION STYLE IN/MM	SCALE ---	DESIGN UNITS METRIC	THIRD ANGLE PROJECTION	
		4 PLACES ± --- ± --- 3 PLACES ± --- ± .010 2 PLACES ± 0.25 ± .014 1 PLACE ± 0.36 ± --- 0 PLACE ± ±	DRAWN BY DATE SAMIEC 2000/03/15 CHECKED BY DATE MUELLER 2000/03/15 APPROVED BY DATE EDGLEY 2000/03/15	TITLE MICRO FIT (3.0) DUAL ROW VERTICAL SMT HEADER W/NAI LS ASS'Y	MATERIAL NO. SEE CHART	DOCUMENT NO. SD-43045-007	SHEET NO. 1 OF 1
		ANGLULAR ±1/2° DRAFT WHERE APPLICABLE MUST REMAIN WITHIN DIMENSIONS					