

## Excellent Integrated System Limited

Stocking Distributor

Click to view price, real time Inventory, Delivery & Lifecycle Information:

[Vishay/Siliconix](#)  
[DG2003DQ-T1-E3](#)

For any questions, you can email us directly:

[sales@integrated-circuit.com](mailto:sales@integrated-circuit.com)



## Low-Voltage Dual SPST Analog Switch

### FEATURES

- Low Voltage Operation (1.8 V to 5.5 V)
- Low On-Resistance -  $r_{DS(on)}$ : 1.2  $\Omega$
- Fast Switching - 14 ns
- Low Charge Injection -  $Q_{INJ}$ : 1 pC
- Low Power Consumption
- TTL/CMOS Compatible
- MSOP-8 Package

### BENEFITS

- Reduced Power Consumption
- Simple Logic Interface
- High Accuracy
- Reduce Board Space

### APPLICATIONS

- Cellular Phones
- Communication Systems
- Portable Test Equipment
- Battery Operated Systems
- Sample and Hold Circuits

### DESCRIPTION

The DG2003/2004/2005 are dual single-pole/single-throw monolithic CMOS analog switch designed for high performance switching of analog signals. Combining low power, fast switching, low on-resistance ( $r_{DS(on)}$ : 1.2  $\Omega$ ) and small physical size (MSOP-8), the DG2003/2004/2005 are ideal for portable and battery powered applications requiring high performance and efficient use of board space.

The DG2003/2004/2005 are built on Vishay Siliconix's low voltage J12 process. An epitaxial layer prevents latchup.

Each switch conducts equally well in both directions when on, and blocks up to the power supply level when off.

### FUNCTIONAL BLOCK DIAGRAM AND PIN CONFIGURATION

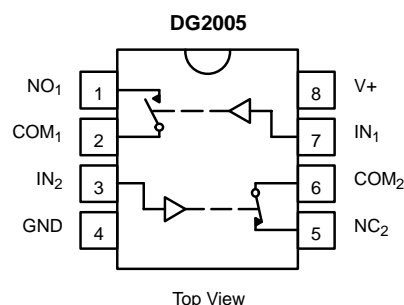
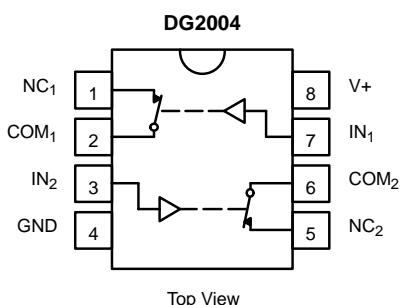
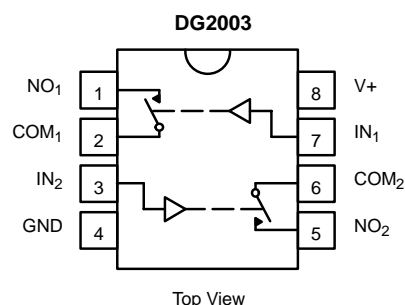

TRUTH TABLE - DG2003	
Logic	NO
0	Off
1	On

TRUTH TABLE - DG2004	
Logic	NC
0	On
1	Off

TRUTH TABLE - DG2005		
Logic	NO <sub>1</sub>	NC <sub>2</sub>
0	Off	On
1	On	Off

ORDERING INFORMATION		
Temp Range	Package	Part Number
-40 to 85°C	MSOP-8	DG2003DQ
		DG2004DQ
		DG2005DQ



# DG2003/2004/2005

Vishay Siliconix

New Product

## ABSOLUTE MAXIMUM RATINGS

Reference to GND

V+	-0.3 to +6 V
IN, COM, NC, NO <sup>a</sup>	-0.3 to (V+ + 0.3 V)
Continuous Current (Any terminal)	± 50 mA
Peak Current	± 200 mA
(Pulsed at 1 ms, 10% duty cycle)	
Storage Temperature (D Suffix)	-65 to 150°C

Power Dissipation (Packages)<sup>b</sup>

MSOP-8 <sup>c</sup>	320 mW
---------------------	--------

Notes:

- Signals on NC, NO, or COM or IN exceeding V+ will be clamped by internal diodes. Limit forward diode current to maximum current ratings.
- All leads welded or soldered to PC Board.
- Derate 6.5 mW/°C above 25°C

SPECIFICATIONS (V+ = 2.0 V)							
Parameter	Symbol	Test Conditions Otherwise Unless Specified V+ = 2.0 V, ± 10%, V <sub>IN</sub> = 0.4 or 1.6 V <sup>e</sup>	Temp <sup>a</sup>	Limits -40 to 85°C			Unit
				Min <sup>b</sup>	Typ <sup>c</sup>	Max <sup>b</sup>	
<b>Analog Switch</b>							
Analog Signal Range <sup>d</sup>	V <sub>NO</sub> , V <sub>NC</sub> , V <sub>COM</sub>		Full	0		V+	V
On-Resistance	r <sub>ON</sub>	V+ = 2.0 V, V <sub>COM</sub> = 1.0 V, I <sub>NO</sub> , I <sub>NC</sub> = 1 mA	Room Full <sup>d</sup>		7.0 12.5	10.0 16.0	Ω
r <sub>ON</sub> Flatness <sup>d</sup>	r <sub>ON</sub> Flatness	V+ = 2.0 V, V <sub>COM</sub> = 0 to V+, I <sub>NO</sub> , I <sub>NC</sub> = 1 mA	Room		5		
Switch Off Leakage Current <sup>f</sup>	I <sub>NO(off)</sub> , I <sub>NC(off)</sub>	V+ = 2.2 V V <sub>NO</sub> , V <sub>NC</sub> = 0.5 V/1.5 V, V <sub>COM</sub> = 1.5 V/0.5 V	Room Full <sup>d</sup>	-500 -4.0		500 4.0	pA nA
	I <sub>COM(off)</sub>		Room Full <sup>d</sup>	-500 -4.0		500 4.0	pA nA
Channel-On Leakage Current <sup>f</sup>	I <sub>COM(on)</sub>	V+ = 2.2 V, V <sub>NO</sub> , V <sub>NC</sub> = V <sub>COM</sub> = 0.5 V/1.5 V	Room Full <sup>d</sup>	-500 -4.0		500 4.0	pA nA
<b>Digital Control</b>							
Input High Voltage	V <sub>INH</sub>		Full	1.6			V
Input Low Voltage	V <sub>INL</sub>		Full			0.4	
Input Capacitance <sup>d</sup>	C <sub>in</sub>		Full		5		pF
Input Current	I <sub>INL</sub> or I <sub>INH</sub>	V <sub>IN</sub> = 0 or V+	Full	-1		1	μA
<b>Dynamic Characteristics</b>							
Turn-On Time	t <sub>ON</sub>	V <sub>NO</sub> or V <sub>NC</sub> = 1.5 V, R <sub>L</sub> = 300 Ω, C <sub>L</sub> = 35 pF Figures 1 and 2	Room Full <sup>d</sup>		30	47 48	ns
Turn-Off Time	t <sub>OFF</sub>		Room Full <sup>d</sup>		22	37 48	
Charge Injection <sup>d</sup>	Q <sub>INJ</sub>	C <sub>L</sub> = 1 nF, V <sub>GEN</sub> = 0 V, R <sub>GEN</sub> = 0 Ω, Figure 3	Room		2		pC
Off-Isolation <sup>d</sup>	OIRR	R <sub>L</sub> = 50 Ω, C <sub>L</sub> = 5 pF, f = 1 MHz	Room		-61		dB
Crosstalk <sup>d</sup>	X <sub>TALK</sub>		Room		-67		
NO, NC Off Capacitance <sup>d</sup>	C <sub>NO(off)</sub> , C <sub>NC(off)</sub>	V <sub>IN</sub> = 0 or V+, f = 1 MHz	Room		53		pF
Channel-On Capacitance <sup>d</sup>	C <sub>ON</sub>		Room		110		
<b>Power Supply</b>							
Power Supply Range	V+			1.8		2.2	V
Power Supply Current <sup>d</sup>	I+	V <sub>IN</sub> = 0 or V+			0.02	1.0	μA
Power Consumption	P <sub>C</sub>						2.2



**DG2003/2004/2005**  
**Vishay Siliconix**

*New Product*

<b>SPECIFICATIONS (V+ = 3.0 V)</b>							
Parameter	Symbol	Test Conditions Otherwise Unless Specified V+ = 3 V, ± 10%, VIN = 0.4 or 2.0 V <sup>e</sup>	Temp <sup>a</sup>	Limits -40 to 85°C			Unit
				Min <sup>b</sup>	Typ <sup>c</sup>	Max <sup>b</sup>	
<b>Analog Switch</b>							
Analog Signal Range <sup>d</sup>	V <sub>NO</sub> , V <sub>NC</sub> , V <sub>COM</sub>		Full	0		V+	V
On-Resistance	r <sub>ON</sub>	V+ = 2.7 V, V <sub>COM</sub> = 1.5 V, I <sub>NO</sub> , I <sub>NC</sub> = 10 mA	Room Full		2.2 2.4	3.5 3.7	Ω
r <sub>ON</sub> Flatness <sup>d</sup>	r <sub>ON</sub> Flatness	V+ = 2.7 V, V <sub>COM</sub> = 0 to V+, I <sub>NO</sub> , I <sub>NC</sub> = 10 mA	Room		0.5		
Switch Off Leakage Current <sup>f</sup>	I <sub>NO(off)</sub> , I <sub>NC(off)</sub>	V+ = 3.3 V V <sub>NO</sub> , V <sub>NC</sub> = 1 V/3 V, V <sub>COM</sub> = 3 V/1 V	Room Full	-500 -6.0		500 6.0	pA nA
	I <sub>COM(off)</sub>		Room Full	-500 -6.0		500 6.0	pA nA
Channel-On Leakage Current <sup>f</sup>	I <sub>COM(on)</sub>	V+ = 3.3 V, V <sub>NO</sub> , V <sub>NC</sub> = V <sub>COM</sub> = 1 V/3 V	Room Full	-500 -6.0		500 6.0	pA nA
<b>Digital Control</b>							
Input High Voltage	V <sub>INH</sub>		Full	2			V
Input Low Voltage	V <sub>INL</sub>		Full			0.4	
Input Capacitance <sup>d</sup>	C <sub>in</sub>		Full		5		pF
Input Current	I <sub>INL</sub> or I <sub>INH</sub>	V <sub>IN</sub> = 0 or V+	Full	-1		1	μA
<b>Dynamic Characteristics</b>							
Turn-On Time <sup>d</sup>	t <sub>ON</sub>	V <sub>NO</sub> or V <sub>NC</sub> = 2.0 V, R <sub>L</sub> = 300 Ω, C <sub>L</sub> = 35 pF Figure 1 and 2	Room Full		19	35 36	ns
Turn-Off Time <sup>d</sup>	t <sub>OFF</sub>		Room Full		17	31 34	
Charge Injection <sup>d</sup>	Q <sub>INJ</sub>	C <sub>L</sub> = 1 nF, V <sub>GEN</sub> = 0 V, R <sub>GEN</sub> = 0 Ω, Figure 3	Room		1		pC
Off-Isolation <sup>d</sup>	OIRR	R <sub>L</sub> = 50 Ω, C <sub>L</sub> = 5 pF, f = 1 MHz	Room		-61		dB
Crosstalk <sup>d</sup>	X <sub>TALK</sub>		Room		-67		
NO, NC Off Capacitance <sup>d</sup>	C <sub>NO(off)</sub> , C <sub>NC(off)</sub>	V <sub>IN</sub> = 0 or V+, f = 1 MHz	Room		53		pF
Channel-On Capacitance <sup>d</sup>	C <sub>ON</sub>		Room		110		
<b>Power Supply</b>							
Power Supply Range	V+			2.7		3.3	V
Power Supply Current	I+	V <sub>IN</sub> = 0 or V+			0.02	1.0	μA
Power Consumption	P <sub>C</sub>						3.3



# DG2003/2004/2005

Vishay Siliconix

New Product

SPECIFICATIONS (V+ = 5.0 V)							
Parameter	Symbol	Test Conditions Otherwise Unless Specified V+ = 5 V, ±10%, V <sub>IN</sub> = 0.8 or 2.4 V <sup>e</sup>	Temp <sup>a</sup>	Limits -40 to 85°C			Unit
				Min <sup>b</sup>	Typ <sup>c</sup>	Max <sup>b</sup>	
<b>Analog Switch</b>							
Analog Signal Range <sup>d</sup>	V <sub>NO</sub> , V <sub>NC</sub> , V <sub>COM</sub>		Full	0		V+	V
On-Resistance	r <sub>ON</sub>	V+ = 4.5 V, V <sub>COM</sub> = 3 V, I <sub>NO</sub> , I <sub>NC</sub> = 10 mA	Room Full		1.2 1.6	2.5 2.7	Ω
r <sub>ON</sub> Flatness <sup>d</sup>	r <sub>ON</sub> Flatness	V+ = 4.5 V, V <sub>COM</sub> = 0 to V+, I <sub>NO</sub> , I <sub>NC</sub> = 10 mA	Room		0.2		
Switch Off Leakage Current	I <sub>NO(off)</sub> , I <sub>NC(off)</sub>	V+ = 5.5 V V <sub>NO</sub> , V <sub>NC</sub> = 1 V/4.5 V, V <sub>COM</sub> = 4.5 V/1 V	Room Full	-1.0 -8.0		1.0 8.0	nA
	I <sub>COM(off)</sub>		Room Full	-1.0 -8.0		1.0 8.0	
Channel-On Leakage Current	I <sub>COM(on)</sub>	V+ = 5.5 V, V+ = 5.5 V V <sub>NO</sub> , V <sub>NC</sub> = V <sub>COM</sub> = 1 V/4.5 V	Room Full	-1.0 -8.0		1.0 8.0	
<b>Digital Control</b>							
Input High Voltage	V <sub>INH</sub>		Full	2.4			V
Input Low Voltage	V <sub>INL</sub>		Full			0.8	
Input Capacitance	C <sub>in</sub>		Full		5		pF
Input Current	I <sub>INL</sub> or I <sub>INH</sub>	V <sub>IN</sub> = 0 or V+	Full	-1		1	μA
<b>Dynamic Characteristics</b>							
Turn-On Time <sup>d</sup>	t <sub>ON</sub>	V <sub>NO</sub> or V <sub>NC</sub> = 3 V, R <sub>L</sub> = 300 Ω, C <sub>L</sub> = 35 pF Figure 1 and 2	Room Full		13	28 31	ns
Turn-Off Time <sup>d</sup>	t <sub>OFF</sub>		Room Full		19	22 31	
Charge Injection <sup>d</sup>	Q <sub>INJ</sub>	C <sub>L</sub> = 1 nF, V <sub>GEN</sub> = 0 V, R <sub>GEN</sub> = 0 Ω, Figure 3	Room		1		pC
Off-Isolation <sup>d</sup>	OIRR	R <sub>L</sub> = 50 Ω, C <sub>L</sub> = 5 pF, f = 1 MHz	Room		-61		dB
Crosstalk <sup>d</sup>	X <sub>TALK</sub>		Room		-67		
Source-Off Capacitance <sup>d</sup>	C <sub>NO(off)</sub> , C <sub>NC(off)</sub>	V <sub>IN</sub> = 0 or V+, f = 1 MHz	Room		51		pF
Channel-On Capacitance <sup>d</sup>	C <sub>ON</sub>		Room		110		
<b>Power Supply</b>							
Power Supply Range	V+			4.5		5.5	V
Power Supply Current	I+	V <sub>IN</sub> = 0 or V+			0.02	1.0	μA
Power Consumption	P <sub>C</sub>						5.5

Notes:

- Room = 25°C, Full = as determined by the operating suffix.
- The algebraic convention whereby the most negative value is a minimum and the most positive a maximum, is used in this data sheet.
- Typical values are for design aid only, not guaranteed nor subject to production testing.
- Guarantee by design, nor subjected to production test.
- V<sub>IN</sub> = input voltage to perform proper function.
- Guaranteed by 5-V leakage testing, not production tested.



**TYPICAL CHARACTERISTICS (25 °C UNLESS NOTED)**

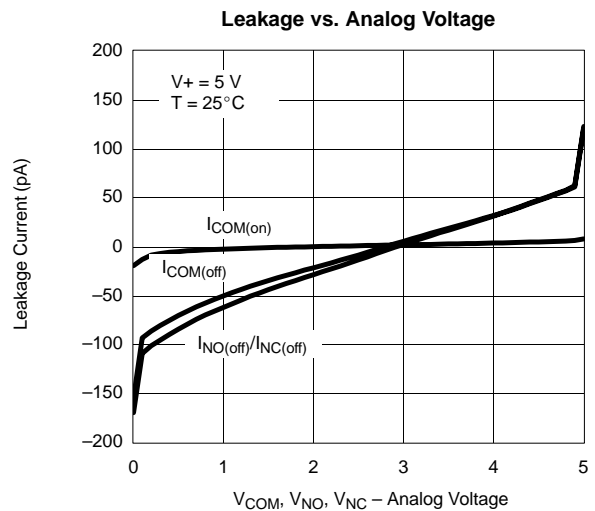
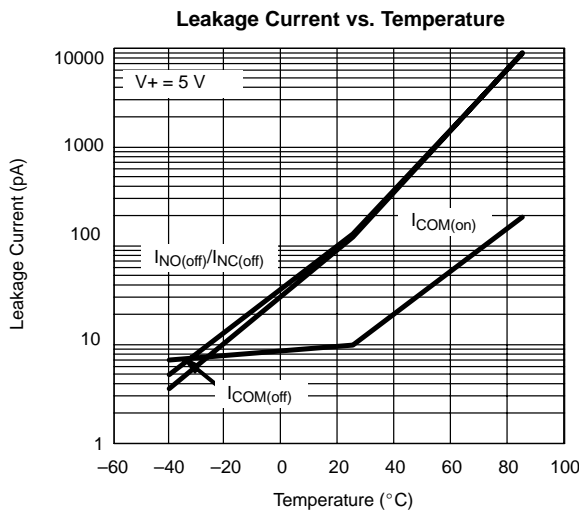
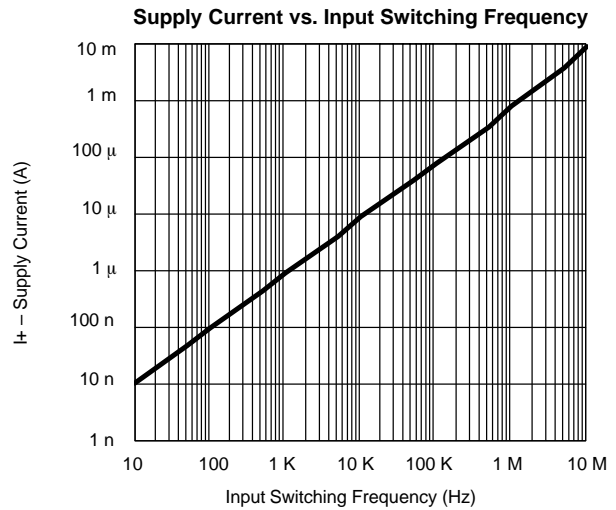
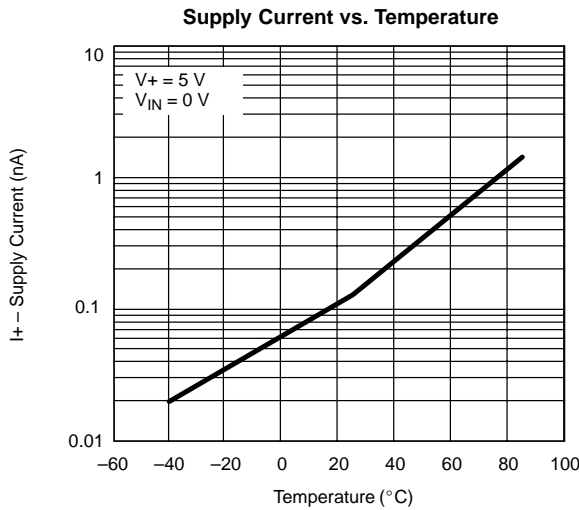
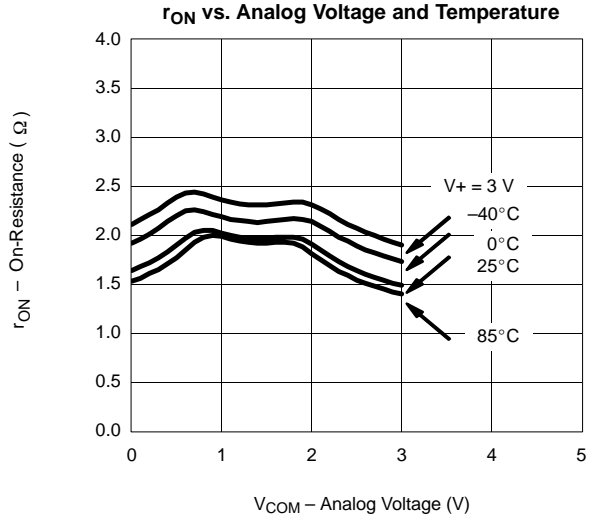
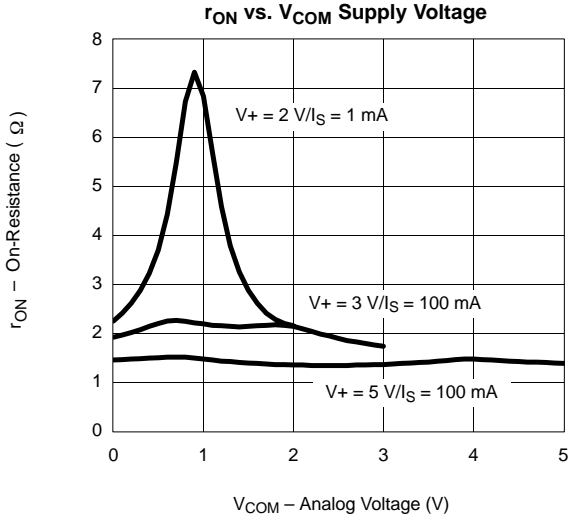

**DG2003/2004/2005**

Vishay Siliconix

New Product



**TYPICAL CHARACTERISTICS (25°C UNLESS NOTED)**

**Switching Time vs. Temperature and Supply Voltage**

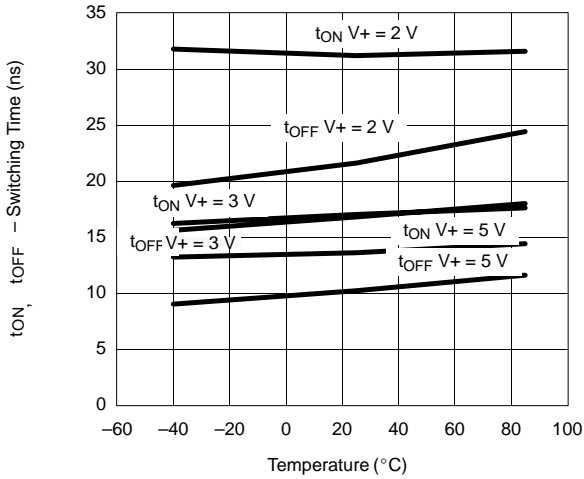

**Insertion Loss, Off-Isolation, Crosstalk vs. Frequency**

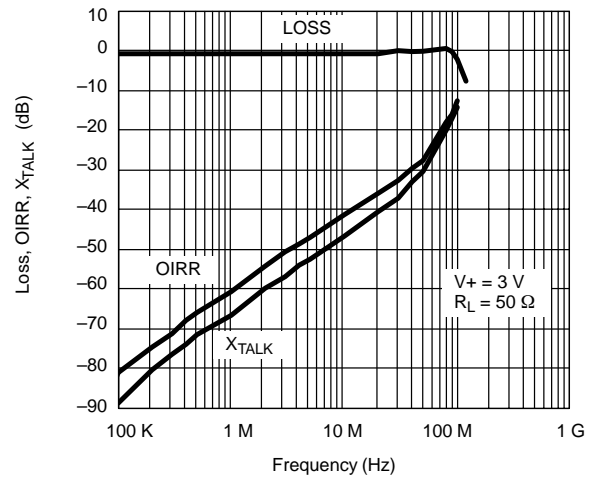

**Switching Threshold vs. Supply Voltage**

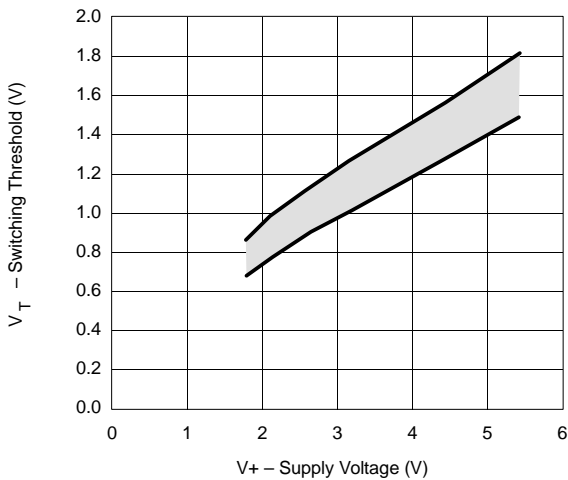

**Charge Injection vs. Analog Voltage**

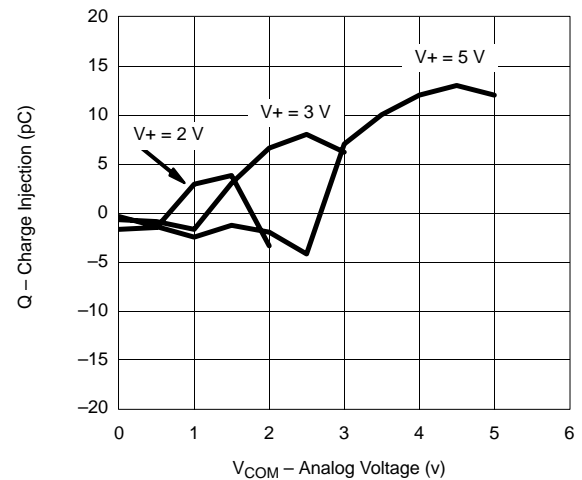



**New Product**

**DG2003/2004/2005**  
**Vishay Siliconix**

**TEST CIRCUITS**

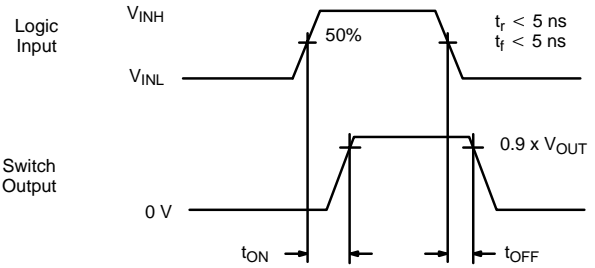
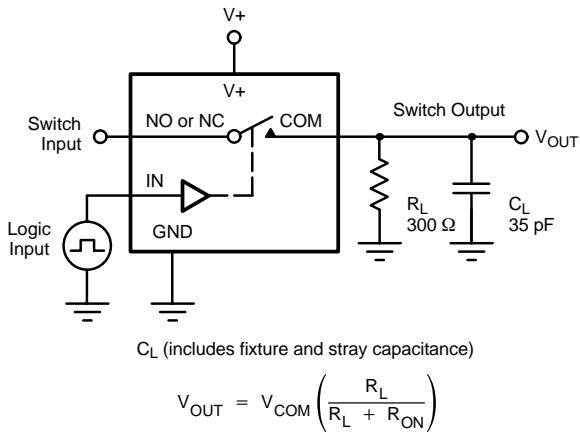

Logic "1" = Switch On  
 Logic input waveforms inverted for switches that have the opposite logic sense.

**FIGURE 1. Switching Time**

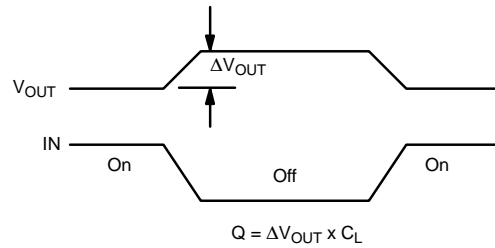
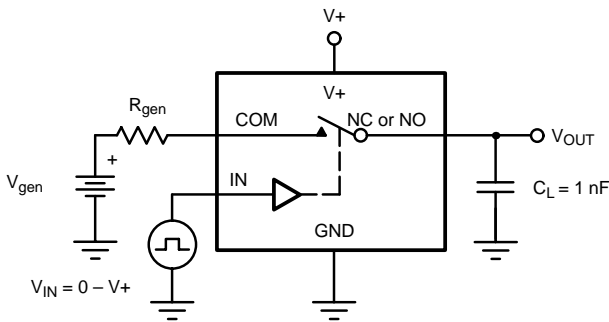

IN depends on switch configuration: input polarity determined by sense of switch.

**FIGURE 2. Charge Injection**

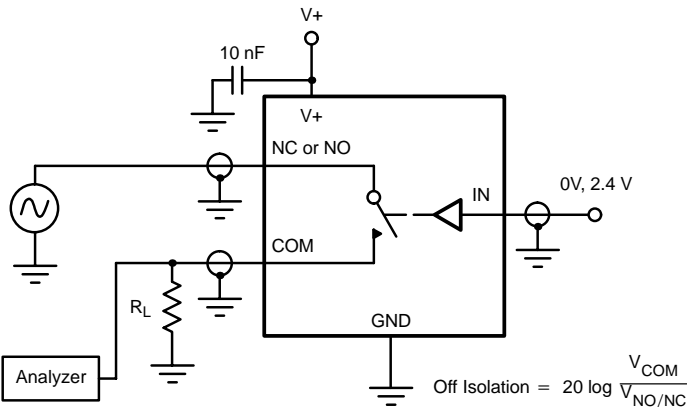

**FIGURE 3. Off-Isolation**

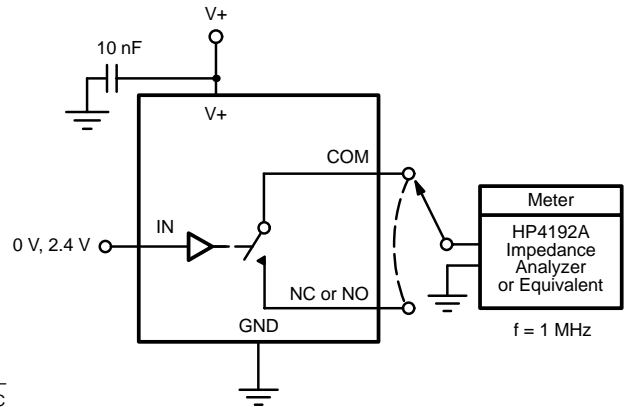

**FIGURE 4. Channel Off/On Capacitance**





## Legal Disclaimer Notice

Vishay

### Disclaimer

All product specifications and data are subject to change without notice.

Vishay Intertechnology, Inc., its affiliates, agents, and employees, and all persons acting on its or their behalf (collectively, "Vishay"), disclaim any and all liability for any errors, inaccuracies or incompleteness contained herein or in any other disclosure relating to any product.

Vishay disclaims any and all liability arising out of the use or application of any product described herein or of any information provided herein to the maximum extent permitted by law. The product specifications do not expand or otherwise modify Vishay's terms and conditions of purchase, including but not limited to the warranty expressed therein, which apply to these products.

No license, express or implied, by estoppel or otherwise, to any intellectual property rights is granted by this document or by any conduct of Vishay.

The products shown herein are not designed for use in medical, life-saving, or life-sustaining applications unless otherwise expressly indicated. Customers using or selling Vishay products not expressly indicated for use in such applications do so entirely at their own risk and agree to fully indemnify Vishay for any damages arising or resulting from such use or sale. Please contact authorized Vishay personnel to obtain written terms and conditions regarding products designed for such applications.

Product names and markings noted herein may be trademarks of their respective owners.