

Excellent Integrated System Limited

Stocking Distributor

Click to view price, real time Inventory, Delivery & Lifecycle Information:

[Vishay/Siliconix](#)
[SI4724CY-T1-E3](#)

For any questions, you can email us directly:

sales@integrated-circuit.com



Si4724

Vishay Siliconix

N-Channel Synchronous MOSFETs With Break-Before-Make

DESCRIPTION

The Si4724CY N-Channel synchronous MOSFET with break-before-make (BBM) is a high speed driver designed to operate in high frequency DC/DC switchmode power supplies. It's purpose is to simplify the use of N-Channel MOSFETs in high frequency buck regulators. This device is designed to be used with any single output PWM IC or ASIC to produce a highly efficient low cost synchronous rectifier converter. A synchronous enable pin (disable = low, enable = high) controls the synchronous function for light load conditions.

The Si4724CY is packaged in Vishay Siliconix's high performance LITTLE FOOT® SO-16 package.

FEATURES

- 0 V to 30 V operation
- Driver impedance-3
- Undervoltage lockout
- Fast switching times
- 30 V MOSFETs
- High side: 0.0375 at $V_{DD} = 4.5\text{ V}$
- Low side: 0.029 at $V_{DD} = 4.5\text{ V}$
- Switching frequency: 250 kHz to 1 MHz
- Integrated schottky



FUNCTIONAL BLOCK DIAGRAM

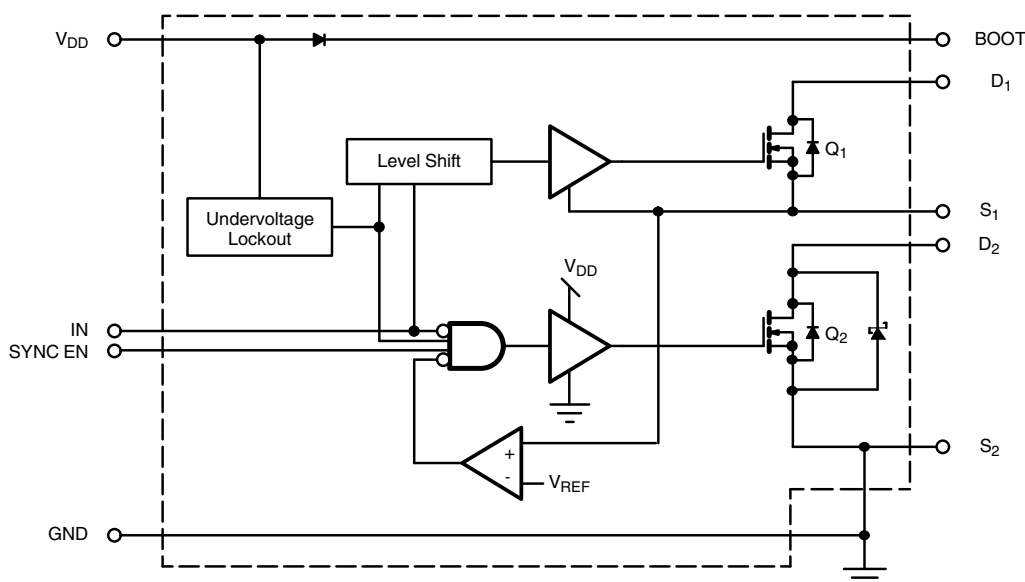

Si4724

Vishay Siliconix



ABSOLUTE MAXIMUM RATINGS ($T_A = 25\text{ }^\circ\text{C}$, unless otherwise noted)				
Parameter	Symbol	Steady State	Unit	
Logic Supply	V_{DD}	7	V	
Logic Inputs	V_{IN}	- 0.7 to $V_{DD} + 0.3$		
Drain Voltage	V_{D1}	30		
Bootstrap Voltage	V_{BOOT}	$V_{S1} + 7$		
Synchronous pin Voltage	V_{SYNC}	- 0.7 to $V_{DD} + 0.3$		
Continuous Drain Current	$T_A = 25\text{ }^\circ\text{C}$	I_{D1}	5.1	A
			$T_A = 70\text{ }^\circ\text{C}$	
	$T_A = 25\text{ }^\circ\text{C}$	I_{D2}	6.5	
			$T_A = 70\text{ }^\circ\text{C}$	
Maximum Power Dissipation ^a	P_D	1.2	W	
Operating Junction and Storage Temperature Range	Driver	T_J, T_{stg}	- 65 to 125	$^\circ\text{C}$
	MOSFETs		- 65 to 150	

Notes:

a. Surface mounted on 1" x 1" FR4 board, full copper two sides.

Stresses beyond those listed under "Absolute Maximum Ratings" may cause permanent damage to the device. These are stress ratings only, and functional operation of the device at these or any other conditions beyond those indicated in the operational sections of the specifications is not implied. Exposure to absolute maximum rating conditions for extended periods may affect device reliability.

RECOMMENDED OPERATING CONDITIONS			
Parameter	Symbol	Steady State	Unit
Drain Voltage	V_{D1}	0 to 30	V
Logic Supply	V_{DD}	4.5 to 5.5	
Input Logic High Voltage	V_{IH}	$0.7 \times V_{DD}$ to V_{DD}	
Input Logic Low Voltage	V_{IL}	- 0.3 to $0.3 \times V_{DD}$	
Bootstrap Capacitor	C_{BOOT}	0.1 to 1	μ
Ambient Temperature	T_A	- 40 to 85	$^\circ\text{C}$

THERMAL RESISTANCE RATINGS								
Parameter	Symbol	Typical	Maximum	Unit				
Highside Junction-to-Ambient ^a	Steady State	R_{thJA1}	85	105	$^\circ\text{C/W}$			
Lowside Junction-to-Ambient ^a						R_{thJA2}	68	85
Highside Junction-to-Foot (Drain) ^b						R_{thJF1}	28	35
Lowside Junction-to-Foot (Drain) ^b						R_{thJF2}	19	24

Notes:

a. Surface mounted on 1" x 1" FR4 board.

b. Junction-to-foot thermal impedance represents the effective thermal impedance of all heat carrying leads in parallel and is intended for use in conjunction with the thermal impedance of the PC board pads to ambient ($R_{thJA} = R_{thJF} + R_{thPCB-A}$). It can also be used to estimate chip temperature if power dissipation and the lead temperature of a heat carrying (drain) lead is known.



SPECIFICATIONS							
Parameter	Symbol	Test Conditions Unless Specified T _A = 25 °C 4.5 V < V _{DD} < 5.5 V, 4.5 V < V _{D1} < 30 V		Limits			Unit
				Min.	Typ.	Max.	
Power Supplies							
Logic Voltage	V _{DD}			4.5		5.5	V
Logic Current	I _{DD(EN)}	V _{DD} = 4.5 V, V _{IN} = 4.5 V			280	500	μA
	I _{DD(DIS)}	V _{DD} = 4.5 V, V _{IN} = 0 V			220	500	
Logic Input							
Logic Input Voltage (V _{IN})	High	V _{IH}	V _{DD} = 4.5 - 40 °C ≤ T _A ≤ 85 °C	3.15	2.3		V
	Low	V _{IL}		- 0.3	2.25	0.8	
Protection							
Break-Before-Make Reference	V _{BBM}	V _{DD} = 5.5			2.4		V
Undervoltage Lockout	V _{UVLO}	SYNC = 4.5		3.75	4	4.25	
Undervoltage Lockout Hysteresis	V _H				0.4		
MOSFET Drivers							
Driver Impedance	R _{DR1}	V _{DD} = 4.5 V	Driver 1		3		V
	R _{DR2}		Driver 2		2		
MOSFETs							
Drain-Source Voltage	V _{DS}	I _D = 250 μA		30			V
Drain Source On State Resistance ^a	R _{DS(on)1}	V _{DD} = 4.5 V, I _D = 5 A T _A = 25 °C		Q1	30	37.5	mΩ
	R _{DS(on)2}			Q2	24	29	
Diode Forward Voltage ^a	V _{SD1}	I _S = 2 A, V _{GS} = 0		Q1	0.7	1.1	V
	V _{SD2}			Q2	0.7	1.1	
Dynamic^b (Unless Specified-F_s = 250 kHz, V_{IN} = 12 V, V_{DD} = 5 V, I = 5 A, Refer to Switching Test Setup)							
Turn Off Delay	t _{d(off)1}	See Timing Diagram		V _{IN} to G ₁	28	56	ns
	t _{d(off)2}			V _{IN} to G ₂	17	40	
Δt	Δt ₁₋₂			G ₁ to G ₂	16	32	
	Δt ₂₋₁			G ₂ to G ₁	38	80	
Source-Drain Reverse Recovery Time-Q ₂	t _{frr}	I _F 2.7 A, di/dt = 100 A/μs			50	80	

Notes:

a. Pulse test; pulse width ≤ 300 μs, duty cycle ≤ 2 %.

b. Typical values are for DESIGN AID ONLY, not guaranteed nor subject to production testing.

SCHOTTKY SPECIFICATIONS (T _J = 25 °C, unless otherwise noted)						
Parameter	Symbol	Test Conditions	Min	Typ	Max	Unit
Forward Voltage Drop	V _F	I _F = 1 A		0.47	0.50	V
		I _F = 1 A, T _J = 125 °C		0.36	0.42	
Maximum Reverse Leakage Current	I _{rm}	V _r = 30 V		0.004	0.100	mA
		V _r = 30 V, T _J = 100 °C		0.7	10	
		V _r = - 30 V, T _J = 125 °C		3	20	
Junction Capacitance	C _T	V _r = 10 V		50		pF

Si4724

Vishay Siliconix



APPLICATION CIRCUIT

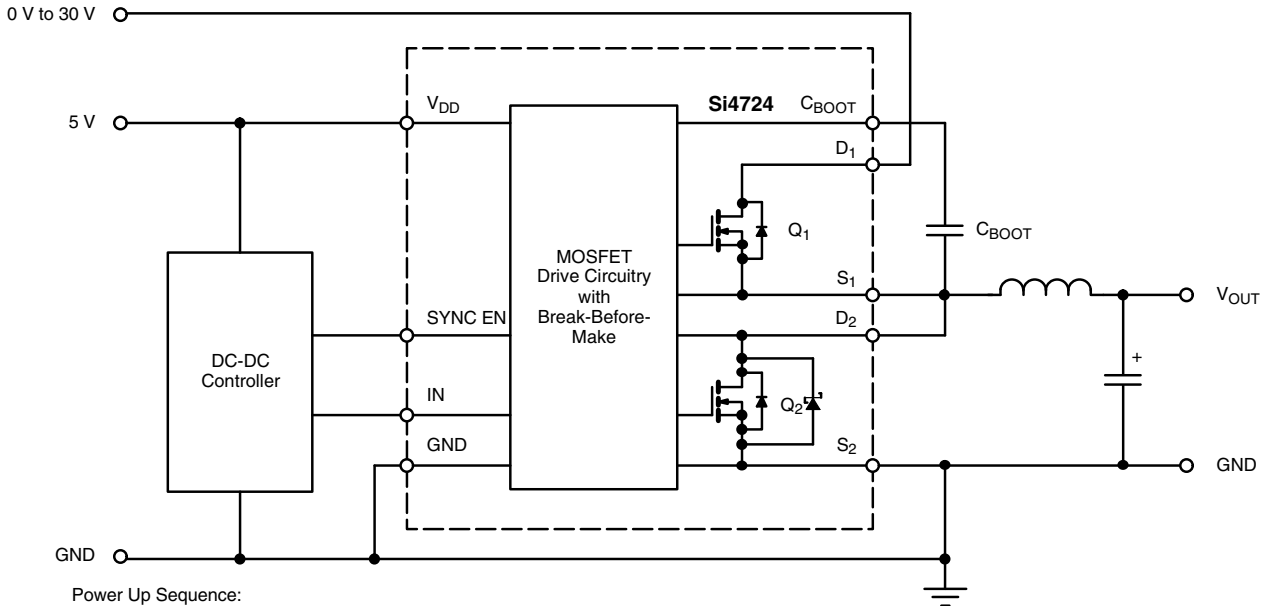

Power Up Sequence:
 Ensure V_{DD} is within spec before allowing IN or SYNC EN to be set high.
Power Down Sequence:
 Ensure IN and SYNC EN are low before turning V_{DD} off.

Figure 1.

PIN CONFIGURATION

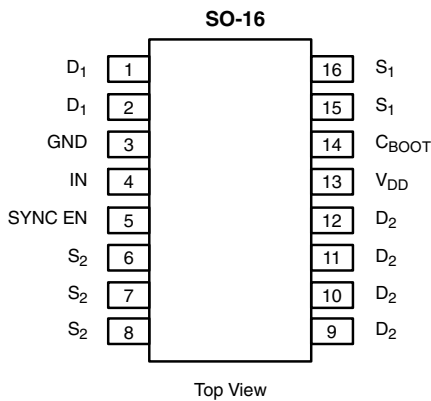

Ordering Information: Si4724CY-T1
 Si4724CY-T1-E3 (Lead (Pb)-free)

TRUTH TABLE			
Sync EN	CLK	Q ₁	Q ₂
H	H	ON	OFF
H	L	OFF	ON
L	H	ON	OFF
L	L	OFF	OFF

PIN DESCRIPTION		
Pin Number	Symbol	Description
1, 2	D ₁	Highside MOSFET Drain
3	GND	Ground
4	IN	Input Logic Signal
5	SYNC EN	Synchronous Enable
6, 7, 8	S ₂	Lowside MOSFET Source
9, 10, 11, 12	D ₂	Lowside MOSFET Drain
13	V _{DD}	Logic Supply, decoupling to GND with a cap is strongly recommended.
14	C _{BOOT}	Bootstrap Capacitor for Upper MOSFET
15, 16	S ₁	Highside MOSFET Source



Si4724
Vishay Siliconix

TIMING DIAGRAM

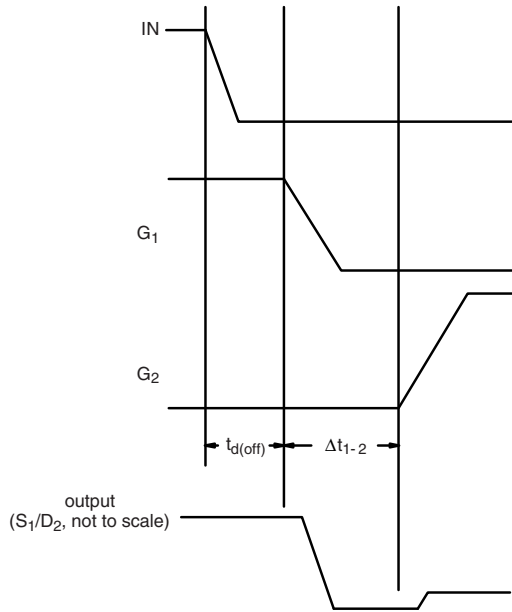

Figure 2. Δt₁₋₂

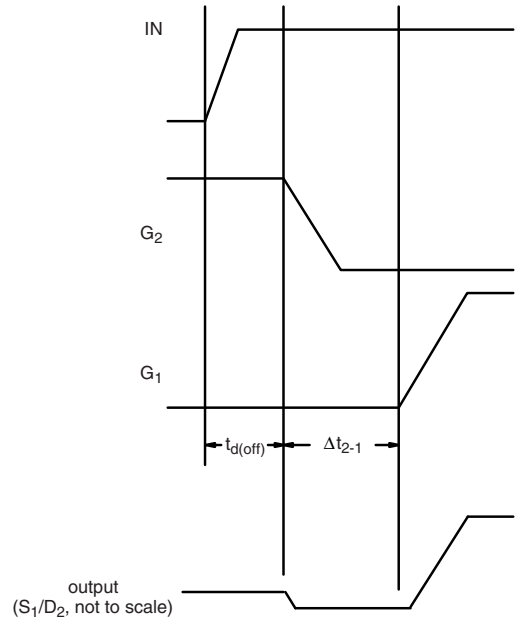

Figure 3. Δt₂₋₁

SWITCHING TEST SET-UP

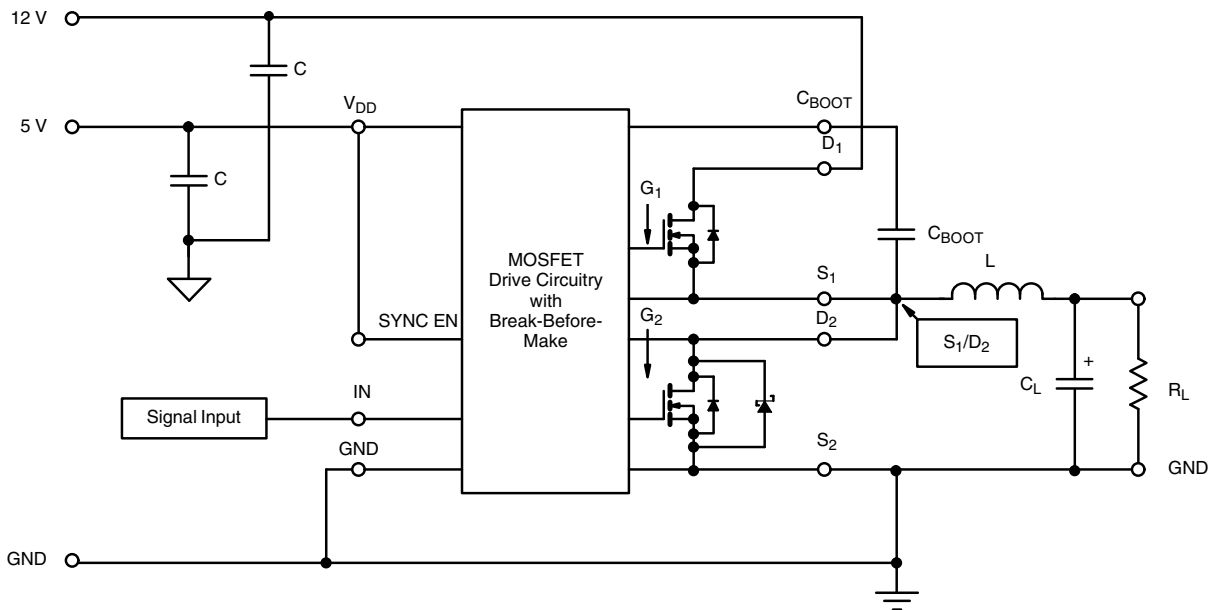

Figure 4.

Si4724

Vishay Siliconix



TYPICAL CHARACTERISTICS (25 °C unless noted)

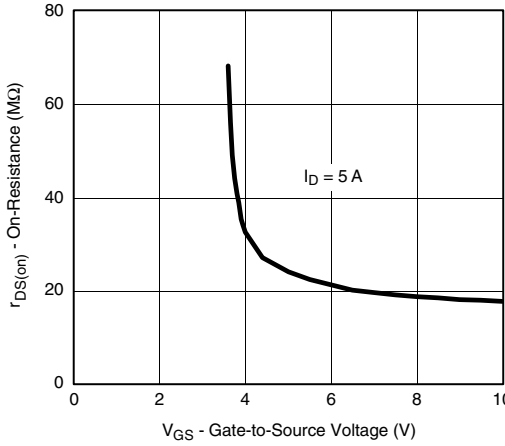

On-Resistance vs. Gate-to-Source Voltage (Q₁)

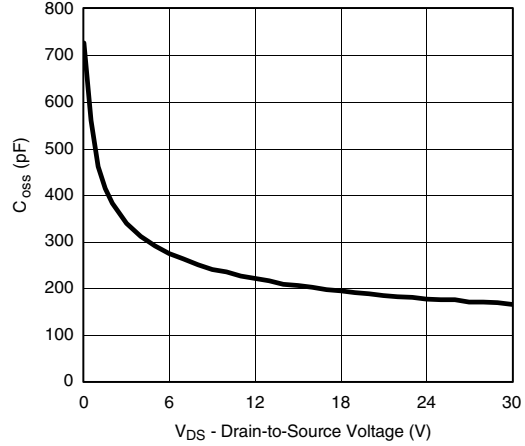

Output Capacitance vs. Drain Voltage (Q₁ and Q₂)

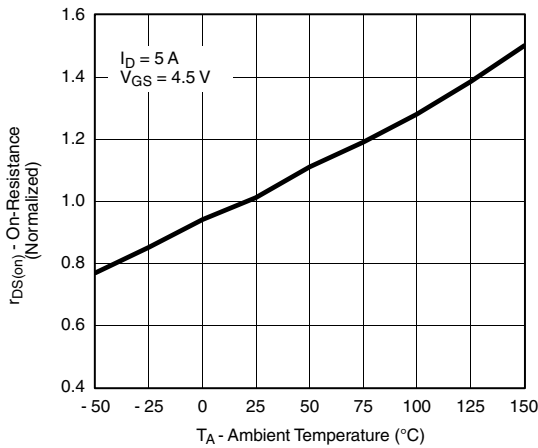

On-Resistance vs. Ambient Temperature

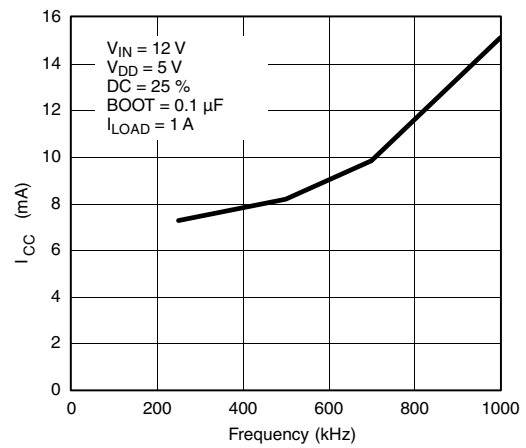

I_{CC} vs. Frequency

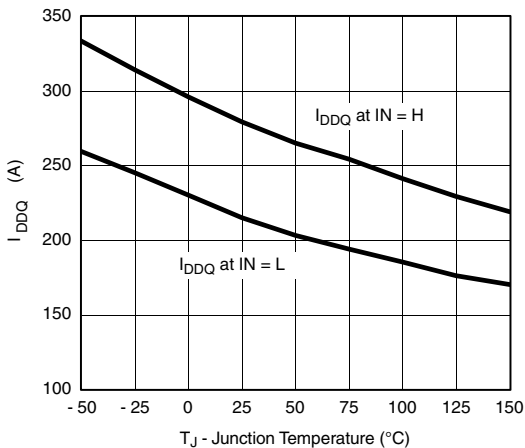

Input Current vs. Junction Temperature

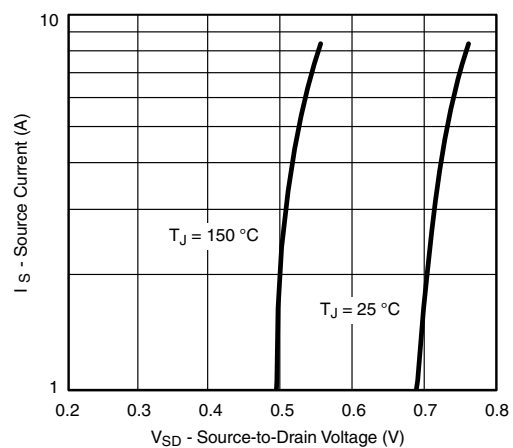

Source-Drain Diode Forward Voltage



TYPICAL CHARACTERISTICS (25 °C unless noted)

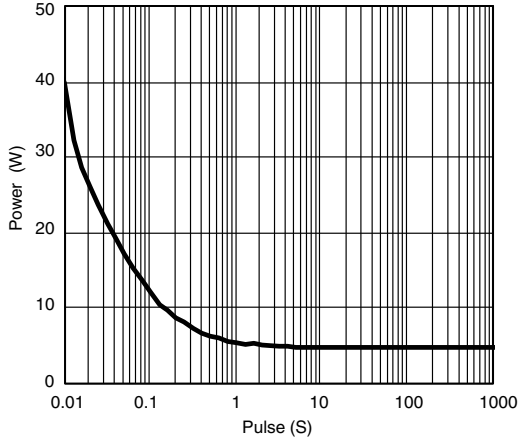

Single Pulse Power, Junction-to-Foot (Q₁)

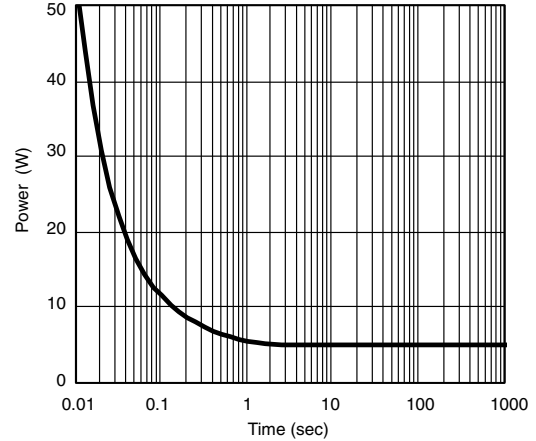

Single Pulse Power, Junction-to-Ambient (Q₁)

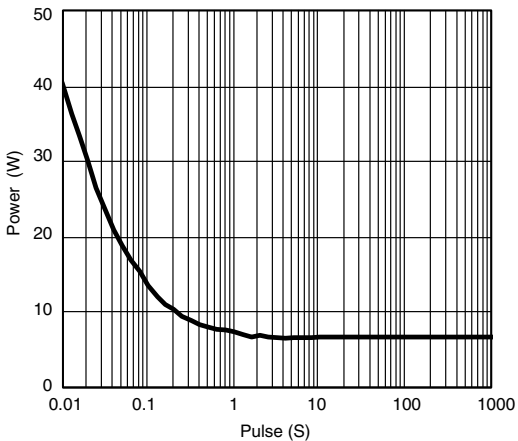

Single Pulse Power, Junction-to-Foot (Q₂)

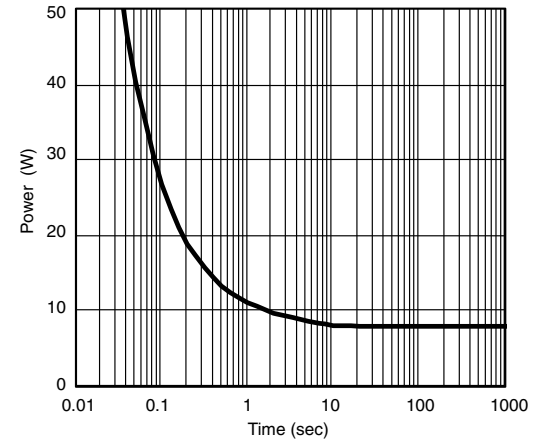

Single Pulse Power, Junction-to-Ambient (Q₂)

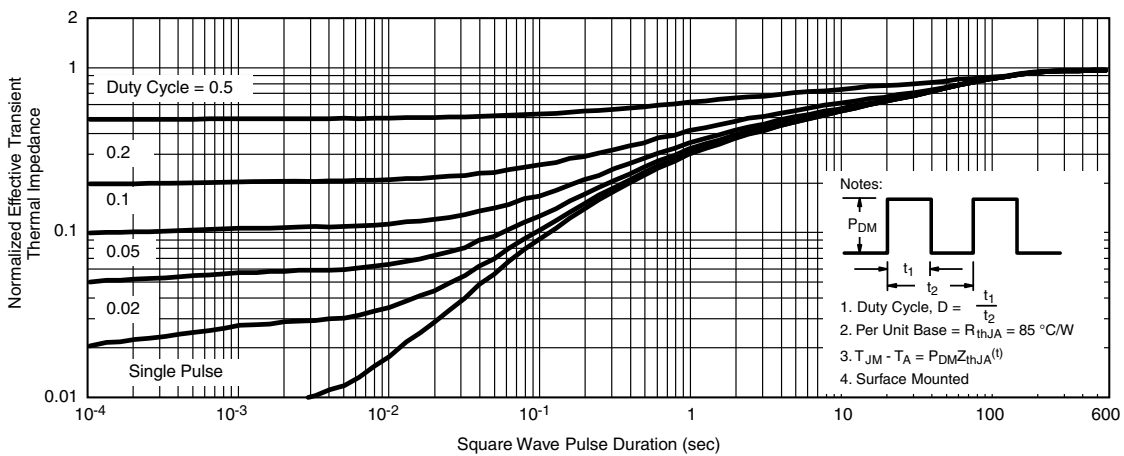

Normalized Thermal Transient Impedance, Junction-to-Ambient (Q₁)

Si4724

Vishay Siliconix



TYPICAL CHARACTERISTICS (25 °C unless noted)

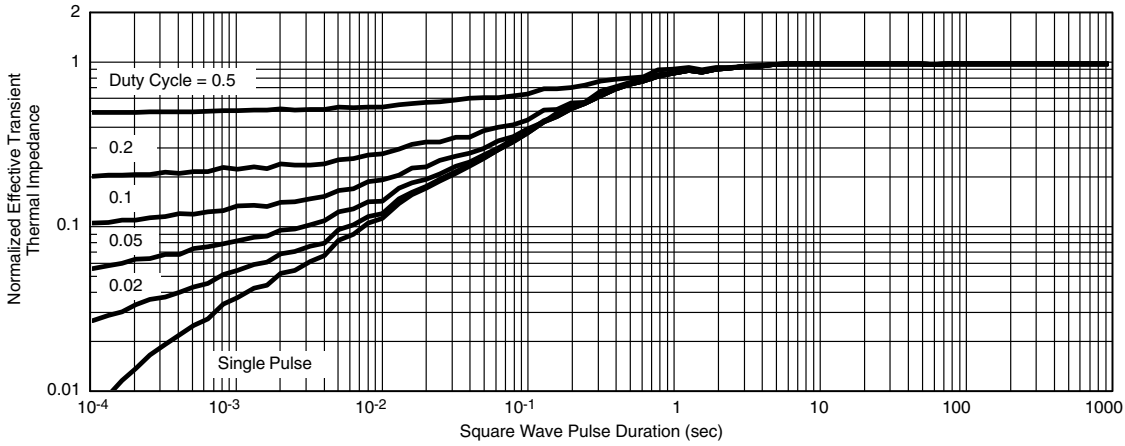

Normalized Thermal Transient Impedance, Junction-to-Foot (Q₁)

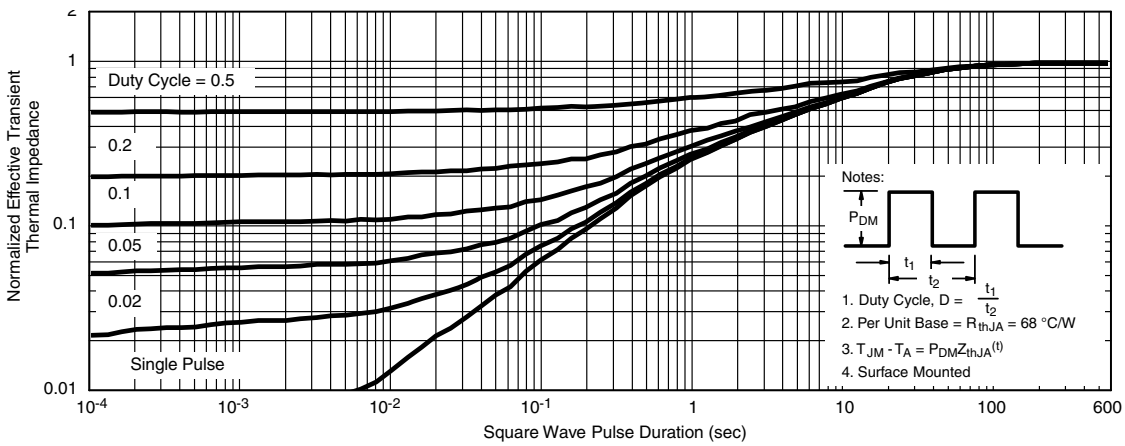

Normalized Thermal Transient Impedance, Junction-to-Ambient (Q₂)

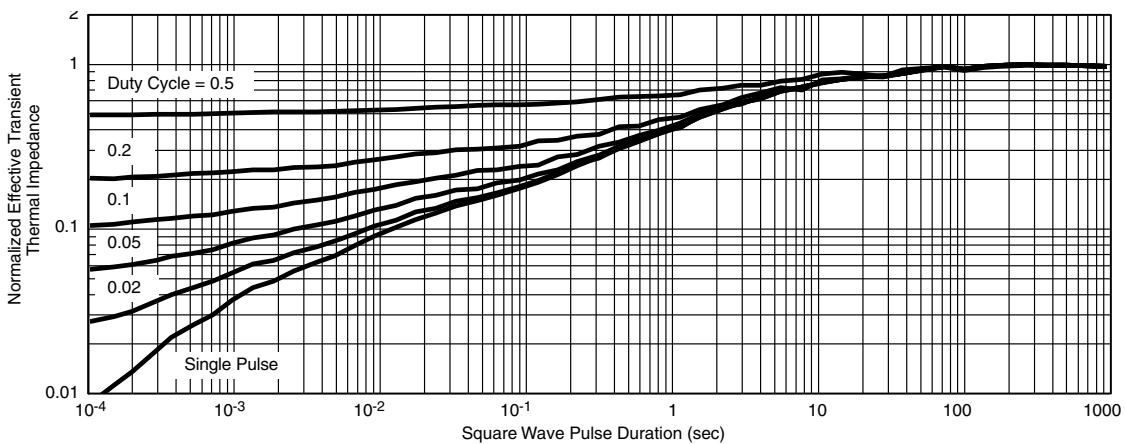

Normalized Thermal Transient Impedance, Junction-to-Foot (Q₂)

Vishay Siliconix maintains worldwide manufacturing capability. Products may be manufactured at one of several qualified locations. Reliability data for Silicon Technology and Package Reliability represent a composite of all qualified locations. For related documents such as package/tape drawings, part marking, and reliability data, see www.vishay.com/ppg271863.



Package Information Vishay Siliconix

SOIC (NARROW): 16-LEAD
 JEDEC Part Number: MS-012

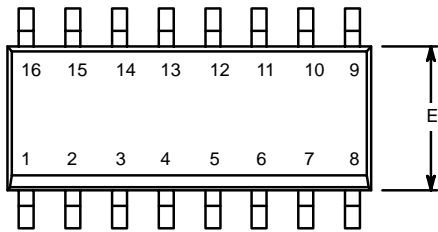

Dim	MILLIMETERS		INCHES	
	Min	Max	Min	Max
A	1.35	1.75	0.053	0.069
A ₁	0.10	0.20	0.004	0.008
B	0.38	0.51	0.015	0.020
C	0.18	0.23	0.007	0.009
D	9.80	10.00	0.385	0.393
E	3.80	4.00	0.149	0.157
e	1.27 BSC		0.050 BSC	
H	5.80	6.20	0.228	0.244
L	0.50	0.93	0.020	0.037
∅	0°	8°	0°	8°

ECN: S-03946—Rev. F, 09-Jul-01
 DWG: 5300

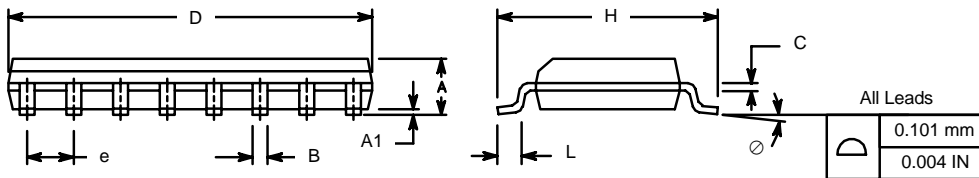

Application Note 826

Vishay Siliconix



RECOMMENDED MINIMUM PADS FOR SO-16

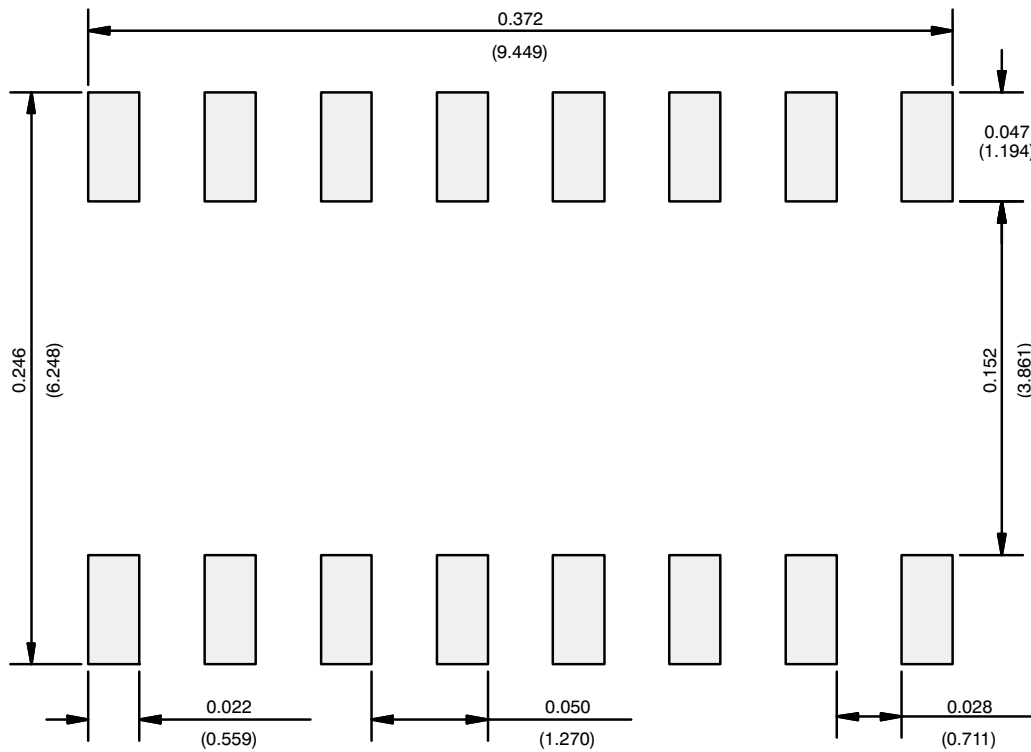

Recommended Minimum Pads
 Dimensions in Inches/(mm)

[Return to Index](#)

APPLICATION NOTE



Disclaimer

ALL PRODUCT, PRODUCT SPECIFICATIONS AND DATA ARE SUBJECT TO CHANGE WITHOUT NOTICE TO IMPROVE RELIABILITY, FUNCTION OR DESIGN OR OTHERWISE.

Vishay Intertechnology, Inc., its affiliates, agents, and employees, and all persons acting on its or their behalf (collectively, "Vishay"), disclaim any and all liability for any errors, inaccuracies or incompleteness contained in any datasheet or in any other disclosure relating to any product.

Vishay makes no warranty, representation or guarantee regarding the suitability of the products for any particular purpose or the continuing production of any product. To the maximum extent permitted by applicable law, Vishay disclaims (i) any and all liability arising out of the application or use of any product, (ii) any and all liability, including without limitation special, consequential or incidental damages, and (iii) any and all implied warranties, including warranties of fitness for particular purpose, non-infringement and merchantability.

Statements regarding the suitability of products for certain types of applications are based on Vishay's knowledge of typical requirements that are often placed on Vishay products in generic applications. Such statements are not binding statements about the suitability of products for a particular application. It is the customer's responsibility to validate that a particular product with the properties described in the product specification is suitable for use in a particular application. Parameters provided in datasheets and / or specifications may vary in different applications and performance may vary over time. All operating parameters, including typical parameters, must be validated for each customer application by the customer's technical experts. Product specifications do not expand or otherwise modify Vishay's terms and conditions of purchase, including but not limited to the warranty expressed therein.

Except as expressly indicated in writing, Vishay products are not designed for use in medical, life-saving, or life-sustaining applications or for any other application in which the failure of the Vishay product could result in personal injury or death. Customers using or selling Vishay products not expressly indicated for use in such applications do so at their own risk. Please contact authorized Vishay personnel to obtain written terms and conditions regarding products designed for such applications.

No license, express or implied, by estoppel or otherwise, to any intellectual property rights is granted by this document or by any conduct of Vishay. Product names and markings noted herein may be trademarks of their respective owners.