

Excellent Integrated System Limited

Stocking Distributor

Click to view price, real time Inventory, Delivery & Lifecycle Information:

[Crydom](#)
[HSP-2](#)

For any questions, you can email us directly:

sales@integrated-circuit.com

HSP SERIES THERMAL PADS

REV. DATE	For Technical Support:
01/15/11	support@crydom.com support-europe@crydom.com

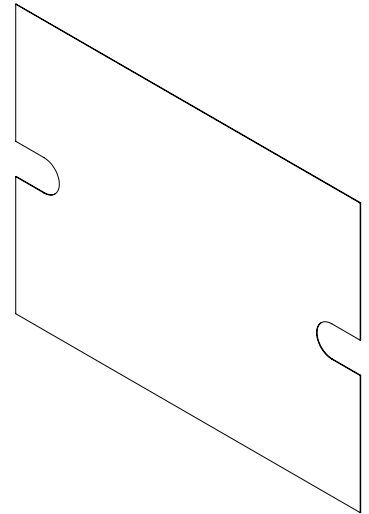
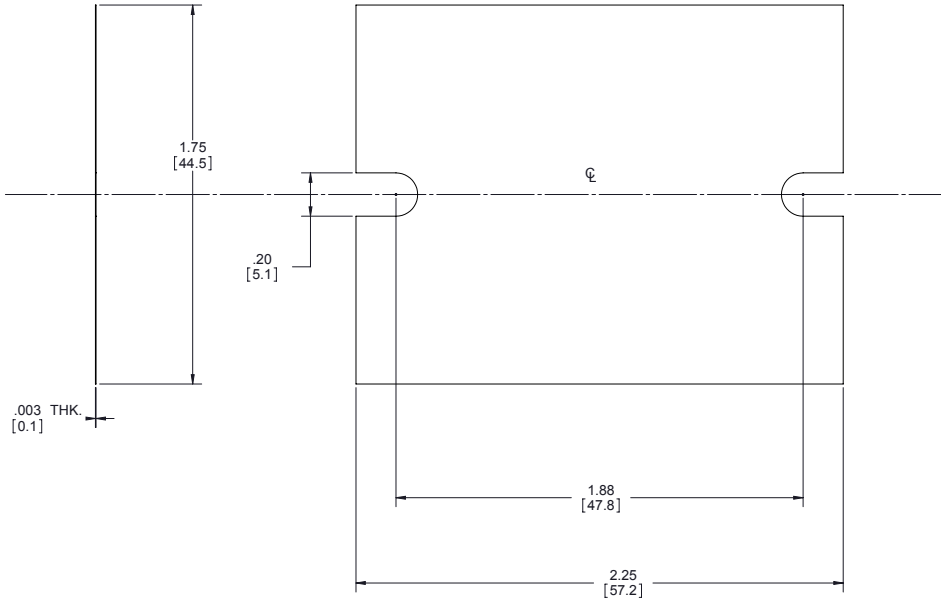

Tolerances: ± 0.02 in / 0.5 mm. All dimensions are in: inches [millimeters]