

Excellent Integrated System Limited

Stocking Distributor

Click to view price, real time Inventory, Delivery & Lifecycle Information:

[Phoenix Contact](#)
[2278429](#)

For any questions, you can email us directly:

sales@integrated-circuit.com



Extract from the online catalog

MKDSO 1,5/ 4-R-3,5 KMGY

Order No.: 2278429



<http://eshop.phoenixcontact.de/phoenix/treeViewClick.do?UID=2278429>

PC terminal block, Nominal current: 8 A, Nom. voltage: 160 V, Pitch: 3.5 mm, Number of positions: 4, Connection method: Screw connection, Mounting: Soldering, Conductor/PCB connection direction: 0 °, Color: light gray, Article with lateral pin exit

Commercial data

GTIN (EAN)	 4 046356 293037
Note	Made-to-order
sales group	F057
Pack	50 pcs.
Customs tariff	85369010
Catalog page information	Page 57 (CC-2009)

Product notes

WEEE/RoHS-compliant since:
05/09/2007



<http://www.download.phoenixcontact.com>
Please note that the data given here has been taken from the online catalog. For comprehensive information and data, please refer to the user documentation. The General Terms and Conditions of Use apply to Internet downloads.

Technical data

Dimensions / positions

Pitch	3.5 mm
Dimension a	10.5 mm
Number of positions	4

MKDSO 1,5/ 4-R-3,5 KMGY Order No.: 2278429

<http://eshop.phoenixcontact.de/phoenix/treeViewClick.do?UID=2278429>

Pin dimensions	0,8 x 0,8 mm
Pin spacing	3.5 mm
Hole diameter	1.2 mm
Screw thread	M2
Tightening torque, min	0.22 Nm
Tightening torque max	0.25 Nm

Technical data

Range of articles	MKDSO 1,5/..-R
Insulating material group	I
Rated surge voltage (III/3)	2.5 kV
Rated surge voltage (III/2)	2.5 kV
Rated surge voltage (II/2)	2.5 kV
Rated voltage (III/3)	160 V
Rated voltage (III/2)	160 V
Rated voltage (II/2)	320 V
Connection in acc. with standard	EN-VDE
Nominal current I_N	8 A
Nominal cross section	1.5 mm ²
Maximum load current	8 A
Insulating material	PA
Inflammability class acc. to UL 94	V0
Internal cylindrical gage	A 1
Stripping length	7 mm

Connection data

Conductor cross section solid min.	0.14 mm ²
Conductor cross section solid max.	1.5 mm ²
Conductor cross section stranded min.	0.14 mm ²
Conductor cross section stranded max.	1.5 mm ²
Conductor cross section stranded, with ferrule without plastic sleeve min.	0.25 mm ²
Conductor cross section stranded, with ferrule without plastic sleeve max.	1.5 mm ²
Conductor cross section stranded, with ferrule with plastic sleeve min.	0.25 mm ²
Conductor cross section stranded, with ferrule with plastic sleeve max.	0.5 mm ²

MKDSO 1,5/ 4-R-3,5 KMGY Order No.: 2278429

<http://eshop.phoenixcontact.de/phoenix/treeViewClick.do?UID=2278429>

Conductor cross section AWG/kcmil min.	28
Conductor cross section AWG/kcmil max	16
2 conductors with same cross section, solid min.	0.08 mm ²
2 conductors with same cross section, solid max.	0.5 mm ²
2 conductors with same cross section, stranded min.	0.08 mm ²
2 conductors with same cross section, stranded max.	0.75 mm ²
2 conductors with same cross section, stranded, ferrules without plastic sleeve, min.	0.25 mm ²
2 conductors with same cross section, stranded, ferrules without plastic sleeve, max.	0.34 mm ²
2 conductors with same cross section, stranded, TWIN ferrules with plastic sleeve, min.	0.5 mm ²
2 conductors with same cross section, stranded, TWIN ferrules with plastic sleeve, max.	0.5 mm ²

Diagrams/Drawings

Drilling plan/solder pad geometry

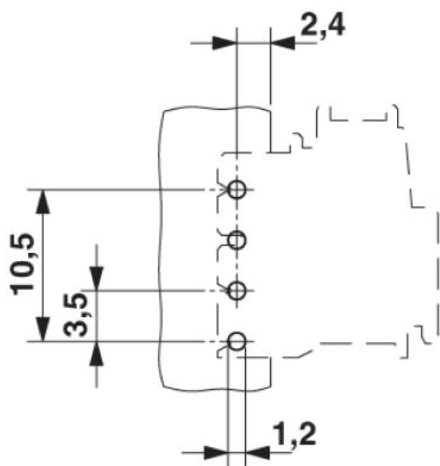

MKDSO 1,5/ 4-R-3,5 KMGY Order No.: 2278429
<http://eshop.phoenixcontact.de/phoenix/treeViewClick.do?UID=2278429>

Diagram

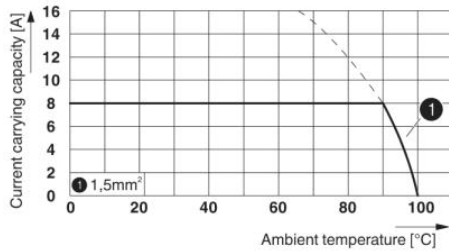

Dimensioned drawing

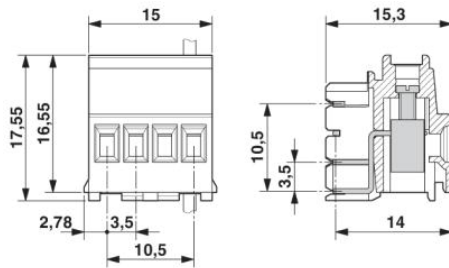

MKDSO 1,5/ 4-R-3,5 KMGY Order No.: 2278429

<http://eshop.phoenixcontact.de/phoenix/treeViewClick.do?UID=2278429>

Address

PHOENIX CONTACT Inc., USA
586 Fulling Mill Road
Middletown, PA 17057, USA
Phone (800) 888-7388
Fax (717) 944-1625
<http://www.phoenixcon.com>



© 2011 Phoenix Contact
Technical modifications reserved;